

# **dji** AVATA 360

## User Manual

v1.0 2026.03

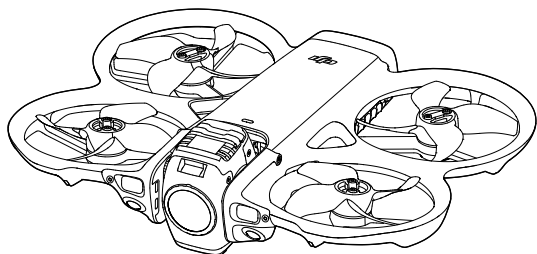



This document is copyrighted by DJI with all rights reserved. Unless otherwise authorized by DJI, you are not eligible to use or allow others to use the document or any part of the document by reproducing, transferring or selling the document. Only refer to this document and the content thereof as instructions to operate DJI products. The document should not be used for other purposes.

In the event of divergence among different versions, the English version shall prevail.

### **Searching for Keywords**

Search for keywords such as “battery” and “install” to find a topic. If you are using Adobe Acrobat Reader to read this document, press Ctrl+F on Windows or Command+F on Mac to begin a search.

### **Navigating to a Topic**

View a complete list of topics in the table of contents. Click on a topic to navigate to that section.

### **Printing this Document**

This document supports high resolution printing.

# Using this Manual

## Legend

⚠ Important

💡 Hints and Tips

📖 Reference

## Read Before Use

DJI™ provides you with tutorial videos and the following documents:

1. *Safety Guidelines*
2. *Quick Start Guide*
3. *User Manual*

It is recommended to watch all the tutorial videos and read the *Safety Guidelines* before using for the first time. Make sure to review the *Quick Start Guide* before using for the first time and refer to this *User Manual* for more information.

## Video Tutorials

Go to the address below or scan the QR code to watch the tutorial videos, which demonstrate how to use the product safely:



<https://www.dji.com/avata-360/video>

## Download the DJI Fly App

Make sure to use DJI Fly during flight. Scan the QR code to download the latest version.





- The remote controller with screen has the DJI Fly app already installed. You are required to download DJI Fly to your mobile device when using the remote controller without screen.
  - To check the Android and iOS operating system versions supported by DJI Fly, visit <https://www.dji.com/downloads/djiapp/dji-fly>.
  - The interface and functions of DJI Fly may vary as the software version is updated. Actual user experience is based on the software version used.
  - For increased safety, flight is restricted to a height of 98.4 ft (30 m) and a range of 164 ft (50 m) when not connected or logged into the app during flight.
  - App login is valid for 90 days. Connect to the internet and log in again when expired.
- 

## Download DJI Studio

Download DJI Studio for video editing at:

<https://www.dji.com/downloads/softwares/dji-studio>

## Download DJI Assistant 2

Download DJI ASSISTANT™ 2 (Consumer Drones Series) at:

<https://www.dji.com/downloads/softwares/dji-assistant-2-consumer-drones-series>



- The operating temperature of this product is -10° to 40° C. It does not meet the standard operating temperature for military-grade application (-55° to 125° C), which is required to endure greater environmental variability. Operate the product appropriately and only for applications that meet the operating temperature range requirements of that grade.
-

# Contents

<b>Using this Manual</b>	<b>3</b>
Legend	3
Read Before Use	3
Video Tutorials	3
Download the DJI Fly App	3
Download DJI Studio	4
Download DJI Assistant 2	4
<b>1 Product Profile</b>	<b>10</b>
1.1 Using for the First Time	10
Preparing the Aircraft	10
Preparing the Remote Controller	11
DJI RC 2	11
Preparing Goggles and Motion Controller	12
Powering on the Goggles	12
Wearing the Goggles	13
Preparing DJI RC Motion 3	14
Activation	14
Firmware Update	15
1.2 Overview	15
Aircraft	15
DJI RC 2 Remote Controller	16
DJI Goggles N3	17
DJI RC Motion 3	17
<b>2 Flight Safety</b>	<b>20</b>
2.1 Flight Restrictions	20
GEO (Geospatial Environment Online) System	20
Flight Limits	20
Flight Altitude and Distance Limits	20
GEO Zones	21
Unlocking GEO Zones	22
2.2 Flight Environment Requirements	22
2.3 Operating the Aircraft Responsibly	23
2.4 Pre-Flight Checklist	24
<b>3 Flight Operation</b>	<b>26</b>
3.1 RC Control	26
Auto Takeoff	26
Auto Landing	26

Starting/Stopping the Motors	27
Starting the Motors	27
Stopping the Motors	27
Stopping the Motors Mid-Flight	27
Controlling the Aircraft	28
Takeoff/Landing Procedures	29
Photos and Videos	29
Intelligent Flight Modes	30
FocusTrack	30
QuickShots	34
Panorama Footage Playback	35
3.2 Immersive Motion Control	35
Basic Flight	35
Taking Off, Braking, and Landing	37
Flying Forward and Backward	37
Adjusting Aircraft Orientation	38
Making the Aircraft Ascend or Descend at an Angle	39
Controlling the Gimbal and Camera	40
Head Tracking	40
Easy ACRO	41
Slide	43
180° Drift	43
Flip	44
Juicy Flick	44
Photos and Videos	44
FocusTrack	44
Notice	45
Using FocusTrack	46
Panorama Footage Playback	47
3.3 Video Suggestions and Tips	47
<b>4 Aircraft</b>	<b>49</b>
4.1 Flight Mode	49
4.2 Aircraft Status Indicators	50
4.3 Return to Home	51
Notice	52
Advanced RTH	53
Trigger Method	53
RTH Procedure	55
RTH Settings	56
Dynamic Home Point	58
Landing Protection	59

4.4	Sensing System	60
	Notice	61
4.5	Advanced Pilot Assistance Systems	62
	Notice	63
	Landing Protection	63
4.6	Vision Assist	63
4.7	Propellers	65
	Attaching/Detaching the Propellers	65
	Notice	66
4.8	Intelligent Flight Battery	67
	Notice	67
	Installing/Removing the Battery	68
	Using the Battery	68
	Charging the Battery	69
	Using a Charger	69
	Using the Charging Hub	70
	Battery Protection Mechanisms	72
4.9	Gimbal and Camera	73
	Gimbal Notice	73
	Gimbal Angle	74
	Gimbal Modes	75
	Camera Notice	75
4.10	Footage Storage and Export	76
	Storing	76
	Exporting	76
	Editing Panoramic Videos	77
4.11	QuickTransfer	77
<b>5</b>	<b>Remote Controller</b>	<b>80</b>
5.1	Remote Controller Operation	80
	Powering On/Off	80
	Charging the Battery	80
	Controlling the Gimbal and Camera	81
	Flight Mode Switch	81
	Flight Pause/RTH Button	81
5.2	Remote Controller LEDs	82
	Status LED	82
	Battery Level LEDs	82
5.3	Remote Controller Alert	83
5.4	Optimal Transmission Zone	83
5.5	Linking the Remote Controller	84
5.6	Operating the Touchscreen	84

<b>6</b>	<b>Goggles and Motion Controller</b>	<b>87</b>
6.1	Goggles Operation	87
	Goggles Buttons	87
	Opening the Menu	87
	AR Cursor	89
	Recenter the Cursor	90
	Operating the Menu	90
	Goggles Footage Storage and Export	92
	Footage Storage	92
	Footage Export	93
	Liveview Sharing	93
	Wired Connection with Smartphone	93
	Broadcasting to Other Goggles	93
6.2	Motion Controller Operation	94
	Button Features	94
	Motion Controller Alert	95
	Optimal Transmission Zone	95
6.3	Linking	96
	Linking via DJI Fly App (recommended)	96
	Linking via Button	96
6.4	Cleaning and Maintenance	97
<b>7</b>	<b>Appendix</b>	<b>100</b>
7.1	Specifications	100
7.2	Compatibility	100
7.3	Firmware Update	100
7.4	Flight Recorder	101
7.5	Post-Flight Checklist	101
7.6	Maintenance Instructions	101
7.7	Troubleshooting Procedures	102
7.8	Risks and Warnings	103
7.9	Disposal	103
7.10	C1 Certification	103
	Direct Remote ID	104
	Remote Controller and Goggles Warnings	105
	GEO Awareness	105
	<b>GEO Zones</b>	106
	EASA Notice	108
	Original Instructions	108
7.11	FAR Remote ID Compliance Information	108
7.12	Aftersales Information	109



# Product Profile

---

# 1 Product Profile

## 1.1 Using for the First Time

Click the link or scan the QR code to watch the tutorial videos.



<https://www.dji.com/avata-360/video>

### Preparing the Aircraft

Remove the gimbal protector from the camera.

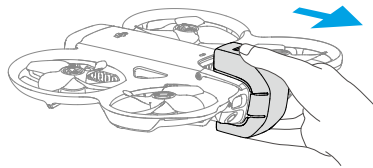

- It is recommended to use the DJI charger to charge the Intelligent Flight Battery. Visit the official DJI website for details.
- It is recommended to attach the gimbal protector when the aircraft is not in use.
- When placing the aircraft, ensure the gimbal is locked and the footpads are facing down.

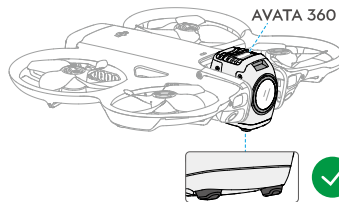

- It is recommended to hold the aircraft as shown in the illustration.

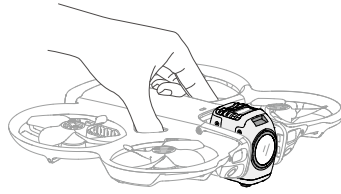

## Preparing the Remote Controller

### DJI RC 2

1. Remove the control sticks from the storage slots and mount them on the remote controller.

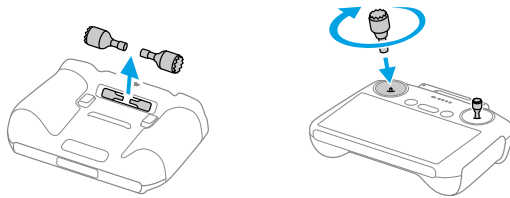

2. Unfold the antennas.

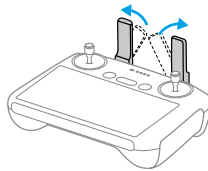

3. The remote controller needs to be activated before first use and an internet connection is required for activation. Press, then press and hold the power button to power on the remote controller. Follow the on-screen prompts to activate the remote controller.

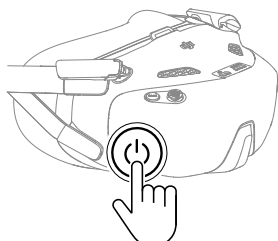

## Preparing Goggles and Motion Controller

### Powering on the Goggles



Press the power button once to check the current battery level.



Press once, then press and hold for two seconds to power the goggles on or off.

Blinking Pattern	Battery Level
 — Solid Green	40-100%
 — Solid Yellow	11-39%
 — Solid Red	1-10%

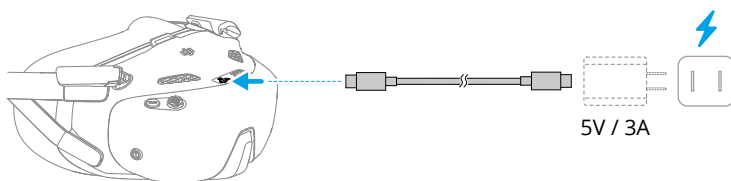
If the battery level is low, it is recommended to use a USB charger to charge the device.



The table below shows the battery level during charging:

Blinking Pattern	Battery Level
 — Pulses Yellow	1-39%
 — Pulses Green	40-99%
 — Solid Green	100%

-  • Using the goggles does not satisfy the requirement of visual line of sight (VLOS). Some countries or regions require a visual observer to assist during flight. Make sure to comply with local laws and regulations when using the goggles.

## Wearing the Goggles

- ⚠ • Fold the antennas to avoid damage when the goggles are not in use.
- DO NOT tear or scratch the foam padding, and the soft side of the battery compartment, or other components with sharp objects.
- The power cable is non-detachable. DO NOT pull the power cable with force to avoid damage.

1. Unfold the antennas.

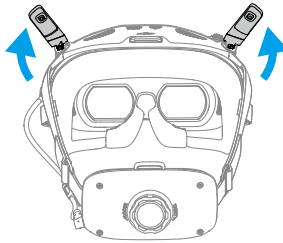

2. Put on the goggles after the devices are powered on.

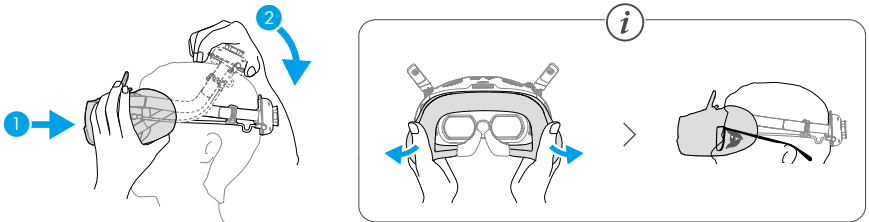

3. Rotate the headband adjustment knob on the battery compartment to adjust the length of the headband.

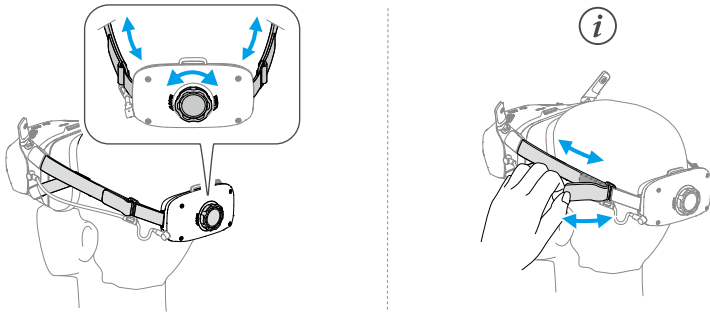

### Preparing DJI RC Motion 3

Press the power button once to check the current battery level. Charge before using if the battery level is too low.

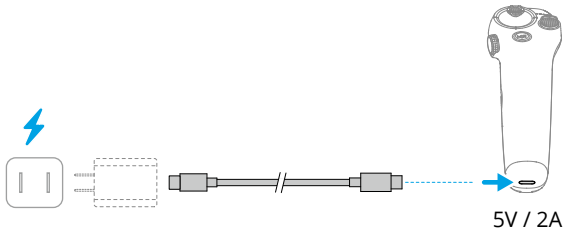

### Activation

The aircraft requires activation before first use. An internet connection is required for activation.

- Remote Controller: Press, then press and hold the power button to power on the aircraft and remote controller respectively. Run DJI Fly and follow the on-screen prompts to activate the aircraft.
- Goggles: Press, then press and hold the power button to power on the aircraft, goggles, and motion controller. Connect the goggles to the mobile device using a suitable data cable. Run DJI Fly on the mobile device and follow the prompts to activate the DJI devices. Follow the prompts in the goggles if unable to connect the mobile device.

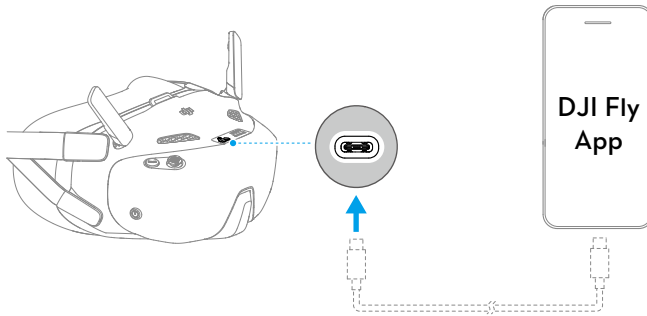

## Firmware Update

A prompt will appear in DJI Fly when a firmware update is available. Update the firmware whenever prompted. Otherwise, some features may not be available.

## 1.2 Overview

### Aircraft

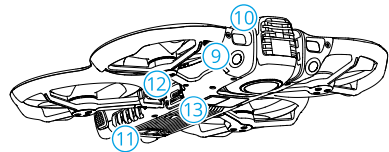
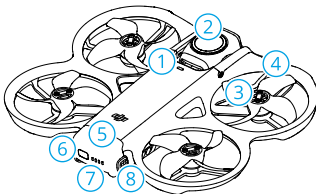

- |                               |   |
|-------------------------------|---|
| 1. Aircraft Status Indicator  | 8. Battery Buckles                            |
| 2. Gimbal and Camera          | 9. Forward/Downward Vision System             |
| 3. Motors                     | 10. Forward-Facing LiDAR <sup>[1]</sup>       |
| 4. Propellers                 | 11. 3D Infrared Sensing System <sup>[1]</sup> |
| 5. Intelligent Flight Battery | 12. USB-C Port                                |
| 6. Power Button               | 13. microSD Card Slot                         |
| 7. Battery Level LEDs         |   |

[1] The 3D infrared sensing system and the forward-facing LiDAR meet the human eye safety requirements for Class 1 Laser products.

## DJI RC 2 Remote Controller

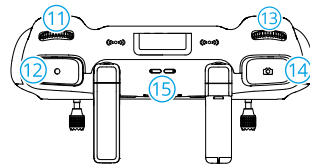
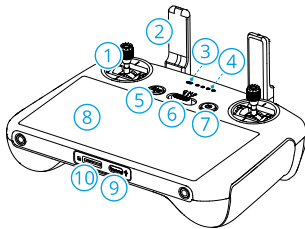

1. Control Sticks
2. Antennas
3. Status LED
4. Battery Level LEDs
5. Flight Pause/Return to Home (RTH) Button
6. Flight Mode Switch
7. Power Button
8. Touchscreen
9. USB-C Port
10. microSD Card Slot
11. Gimbal Dial
12. Record Button

13. Camera Control Dial <sup>[1]</sup>
14. Shutter Button
15. Speaker
16. Control Stick Storage Slots
17. Customizable C2 Button <sup>[1]</sup>
18. Customizable C1 Button <sup>[1]</sup>

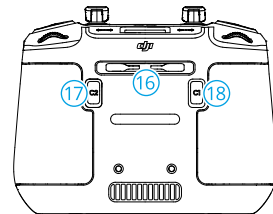

[1] To view and set the button function, go to camera view in DJI Fly, and tap \*\*\* > Control > Button Customization.



## DJI Goggles N3

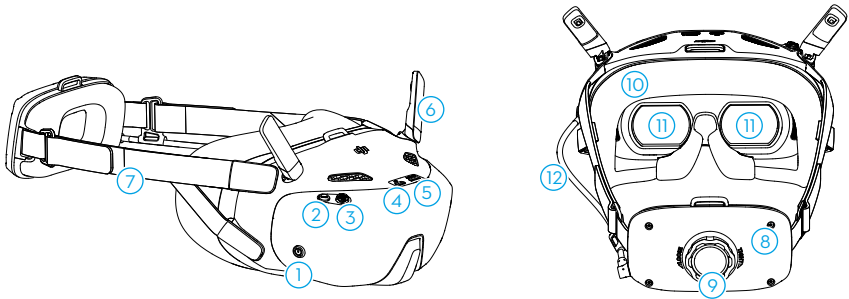

- |                      |                             |
|----------------------|-----------------------------|
| 1. Power Button      | 7. Headband                 |
| 2. Back Button       | 8. Battery Compartment      |
| 3. 5D Button         | 9. Headband Adjustment Knob |
| 4. USB-C Port        | 10. Foam Padding            |
| 5. microSD Card Slot | 11. Lens                    |
| 6. Antennas          | 12. Power Cable             |

- 
- 💡 • When the goggles are connected to a smartphone or a PC, if the devices do not respond after connecting, go to the goggles menu and select **Settings > About**, and enter the OTG Wired Connection mode. If the devices still do not respond after connecting, use a different data cable and try again.
- 

## DJI RC Motion 3

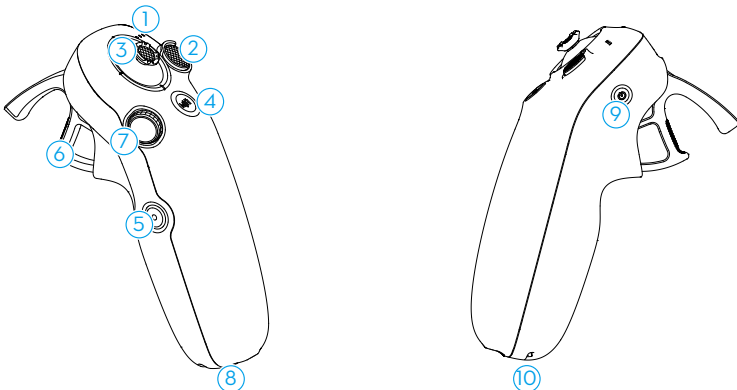

1. Battery Level LEDs
2. Lock Button
3. Joystick
4. Mode Button
5. Shutter/Record Button
6. Accelerator
7. Dial
8. USB-C Port
9. Power Button
10. Lanyard Hole

# Flight Safety

---

## 2 Flight Safety

After completing pre-flight preparations, it is recommended to train your flying skills and practice flying safely. Pick a suitable area to fly in according to the following flight requirements and restrictions. Strictly abide by local laws and regulations when flying. Read the *Safety Guidelines* before flight to ensure safe use of the product.

### 2.1 Flight Restrictions

#### GEO (Geospatial Environment Online) System

The DJI Geospatial Environment Online (GEO) System is a global information system that provides real-time information on flight safety and restriction updates and prevents UAVs from flying in restricted airspace. Under exceptional circumstances, restricted areas can be unlocked to allow flights. Prior to that, you must submit an unlocking request based on the current restriction level in the intended flight area. The GEO system may not fully align with local laws and regulations. You are responsible for your own flight safety and must consult with the local authorities on the relevant legal and regulatory requirements before requesting to unlock a restricted area. For more information about the GEO system, visit <https://fly-safe.dji.com>.

#### Flight Limits

For safety reasons, flight limits are enabled by default to help you operate the aircraft safely. You can set flight limits on height and distance. Altitude limits, distance limits, and GEO zones function concurrently to manage flight safety when Global Navigation Satellite System (GNSS) is available. Only altitude can be limited when GNSS is unavailable.

#### Flight Altitude and Distance Limits

Max altitude restricts the flight altitude of the aircraft, while max distance restricts the flight radius around the Home Point of the aircraft. These limits can be changed in the DJI Fly app for improved flight safety.

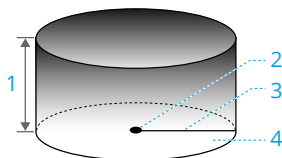

1. Max Altitude
2. Home Point (Horizontal Position)
3. Max Distance
4. Height of aircraft when taking off

*Strong GNSS Signal*

	Flight Restrictions	Prompt in DJI Fly App
Max Altitude	Altitude of the aircraft cannot exceed the value set in DJI Fly.	Max flight altitude reached.
Max Distance	The straight-line distance from the aircraft to the Home Point cannot exceed the max flight distance set in DJI Fly.	Max flight distance reached.

*Weak GNSS Signal*

	Flight Restrictions	Prompt in DJI Fly App
Max Altitude	<ul style="list-style-type: none"> <li>Altitude is restricted to 30 m from the takeoff point if lighting is sufficient.</li> <li>Altitude is restricted to 3 m above the ground if lighting is not sufficient and the 3D infrared sensing system is functioning.</li> <li>Altitude is restricted to 30 m from the takeoff point if lighting is not sufficient and the 3D infrared sensing system is not functioning.</li> </ul>	Max flight altitude reached.
Max Distance	No limit	

-  • Each time the aircraft is powered on, the altitude limit will be automatically removed as long as the GNSS signal becomes strong (GNSS signal strength  $\geq 2$ ), and the limit will not take effect even if the GNSS signal becomes weak afterwards.
- If the aircraft flies out of the set flight range due to inertia, you can still control the aircraft but cannot fly it any further away.

**GEO Zones**

The DJI GEO system designates safe flight locations, provides risk levels and safety notices for individual flights, and offers information on restricted airspace. All restricted flight areas are referred to as GEO Zones, which are further divided into Restricted Zones, Authorization Zones, Warning Zones, Enhanced Warning Zones, and Altitude

Zones. You can view such information in real-time in DJI Fly. GEO Zones are specific flight areas, including but not limited to airports, large event venues, locations where public emergencies have occurred (such as forest fires), nuclear power plants, prisons, government properties, and military facilities. By default, the GEO system limits takeoffs and flights in zones that may cause safety or security concerns. A GEO Zone map that contains comprehensive information on GEO Zones around the globe is available on the official DJI website: <https://fly-safe.dji.com/nfz/nfz-query>.

## Unlocking GEO Zones

**Self-Unlocking** is intended for unlocking Authorization Zones. To complete Self-Unlocking, you must submit an unlocking request via the DJI FlySafe website at <https://fly-safe.dji.com>. Once the unlocking request is approved, you can synchronize the unlocking license through the DJI Fly app. To unlock the zone, alternatively, you can launch or fly the aircraft directly into the approved Authorization Zone and follow the prompts in DJI Fly to unlock the zone.

**Custom Unlocking** is tailored for users with special requirements. It designates user-defined custom flight areas and provides flight permission documents specific to the needs of different users. This unlocking option is available in all countries and regions and can be requested via the DJI FlySafe website at <https://fly-safe.dji.com>.

## 2.2 Flight Environment Requirements

1. DO NOT fly in severe weather conditions such as strong winds, snow, rain, and fog.
2. Only fly in open areas. Tall buildings and large metal structures may affect the accuracy of the onboard compass and GNSS system. After takeoff, make sure you are notified with the voice prompt that the Home Point is updated before continuing flight. If the aircraft has taken off near buildings, the accuracy of the Home Point cannot be guaranteed. In this case, pay close attention to the current position of the aircraft during auto RTH. When the aircraft is close to the Home Point, it is recommended to cancel auto RTH and manually control the aircraft to land at an appropriate location.
3. Fly the aircraft within visual line of sight (VLOS). Avoid mountains and trees blocking GNSS signals. Any flight beyond visual line of sight (BVLOS) can be conducted only when the aircraft performance, the knowledge and skills of the pilot, and the operational safety management are compliant with local regulations for BVLOS. Avoid obstacles, crowds, trees, and bodies of water. For safety reasons, DO NOT fly the aircraft near airports, highways, railway stations, railway lines, city centers, or other sensitive areas, unless any permit or approval is obtained under local regulations.

Ensure there are no obstructions between the remote control device and the aircraft to avoid interference with communication.

4. When the GNSS signal is weak, fly the aircraft in environments with good lighting and visibility. The vision system may not work properly in poor light conditions. Only fly the aircraft in the daytime.
5. Minimize interference by avoiding areas with high levels of electromagnetism, such as locations near power lines, base stations, electrical substations, and broadcasting towers.
6. The performance of the aircraft and its battery is limited when flying at high altitudes. Fly with caution. DO NOT fly above the specified altitude.
7. The braking distance of the aircraft is affected by the flight altitude. The higher the altitude, the greater the braking distance. When flying at high altitudes, you should reserve adequate braking distance to ensure flight safety.
8. GNSS cannot be used on the aircraft in polar regions. Use the vision system instead.
9. DO NOT take off from moving objects such as cars, ships, and airplanes.
10. DO NOT take off from solid-colored surfaces or surfaces with strong reflections such as a car roof.
11. Be careful when taking off in the desert or from a beach to avoid sand entering the aircraft.
12. DO NOT operate the aircraft in an environment at risk of a fire or explosion.
13. Use the aircraft and related devices in dry environments.
14. DO NOT use the aircraft and related devices in the following environments: accident scenes, fires, explosions, floods, tsunamis, avalanches, landslides, earthquakes, areas with dust or sandstorms. During operation, be sure to avoid exposure to salt spray and mold.
15. DO NOT operate the aircraft near bird flocks.

## 2.3 Operating the Aircraft Responsibly

To avoid serious injury and property damage, observe the following rules:

1. Make sure you are NOT under the influence of anesthesia, alcohol, or drugs or suffering from dizziness, fatigue, nausea, or other conditions that could impair the ability to operate the aircraft safely.
2. After landing, power off the aircraft first, then switch off the remote controller.
3. DO NOT drop, launch, fire, or otherwise project any dangerous payloads on or at any buildings, persons, or animals, which could cause personal injury or property damage.

4. DO NOT use an aircraft that has been accidentally damaged, crashed, or is not in good condition.
5. Make sure to train sufficiently and have contingency plans for emergencies or if an incident occurs.
6. Make sure to have a flight plan. DO NOT fly the aircraft recklessly.
7. Respect the privacy of others when using the camera. Make sure to comply with local privacy laws, regulations, and moral standards.
8. DO NOT use this product for any reason other than general personal use.
9. DO NOT use it for illegal or inappropriate purposes such as spying, military operations, or unauthorized investigations.
10. DO NOT use this product to defame, abuse, harass, stalk, threaten, or otherwise violate legal rights such as the right to privacy and publicity of others.
11. DO NOT trespass onto the private property of others.

## 2.4 Pre-Flight Checklist

1. Remove any protective parts from the aircraft.
2. Make sure the Intelligent Flight Battery and the propellers are mounted securely.
3. Make sure the remote controller, mobile device, and Intelligent Flight Battery are fully charged.
4. Make sure the microSD card slot cover is firmly closed to prevent it from appearing in footage.
5. Make sure the gimbal and camera are functioning normally.
6. Make sure that there is nothing obstructing the motors and that they are functioning normally.
7. Make sure all camera lenses and sensors are clean. If there are smudges, dust, or water droplets, clean them with a lens cloth.
8. DO NOT install uncertified accessories or external devices, as this may result in product damage or safety hazards.
9. Make sure the obstacle avoidance action is set in DJI Fly or the goggles (if in use), and the **Max Altitude**, **Max Distance** and **Auto RTH Altitude** are all set properly according to local laws and regulations.



# Flight Operation

---

## 3 Flight Operation

The aircraft supports multiple control methods for various scenarios to meet your needs. Make sure you are familiar with the notice and usage for each control method before flight.



- 
- ⚠ • DO NOT touch the aircraft mid-flight. Otherwise, the aircraft may drift and a collision may occur.
  - DO NOT fly the aircraft immediately after it has been in a collision or severely knocked or shaken. The aircraft may not be able to perform stable flight.
  - The gimbal will automatically rotate during takeoff and landing, and the camera view will change accordingly. Brief stutters during this process are normal.
- 

### 3.1 RC Control

#### Auto Takeoff

1. Launch DJI Fly and enter the camera view.
2. Complete all steps in the pre-flight checklist.
3. Tap . If conditions are safe for takeoff, press and hold the button to confirm.
4. The aircraft will take off and hover above the ground.

#### Auto Landing

1. If conditions are safe to land, tap , then tap and hold  to confirm.
2. Auto landing can be canceled by tapping .
3. If the Downward Vision System is working normally, Landing Protection will be enabled.
4. Motors will stop automatically after landing.

- 
- ⚠ • Choose an appropriate place for landing.
-

## Starting/Stopping the Motors

### Starting the Motors

Perform one of the Combination Stick Commands (CSC) as shown below to start the motors. Once the motors have started spinning, release both sticks simultaneously.



### Stopping the Motors

The motors can be stopped in two ways:

**Method 1:** When the aircraft has landed, push the throttle stick down and hold until the motors stop.

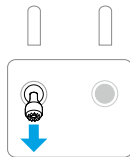

**Method 2:** When the aircraft has landed, perform one of the CSC as shown below until the motors stop.



### Stopping the Motors Mid-Flight

⚠ • Stopping the motors mid-flight will cause the aircraft to crash.

The default setting for **Emergency Propeller Stop** in the DJI Fly app is **Emergency Only**, which means that the motors can only be stopped mid-flight when the aircraft detects that it is in an emergency situation such as the aircraft is involved in a collision, a motor

has stalled, the aircraft is rolling in the air, or the aircraft is out of control and is ascending or descending very quickly. To stop the motors mid-flight, perform the same CSC that was used to start the motors. Note that you need to hold the control sticks for two seconds while performing the CSC to stop the motors. **Emergency Propeller Stop** can be changed to **Anytime** in the app. Use this option with caution.

## Controlling the Aircraft

The control sticks of the remote controller can be used to control the aircraft movements. The control sticks can be operated in Mode 1, Mode 2, or Mode 3, as shown below.

The default control mode of the remote controller is Mode 2. In this manual, Mode 2 is used as an example to illustrate how to use the control sticks. The more the stick is pushed away from the center, the faster the aircraft moves.

### Mode 1

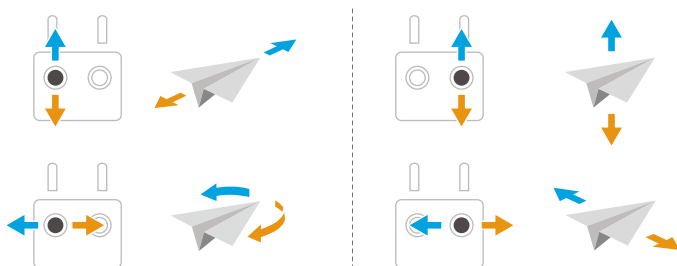

### Mode 2

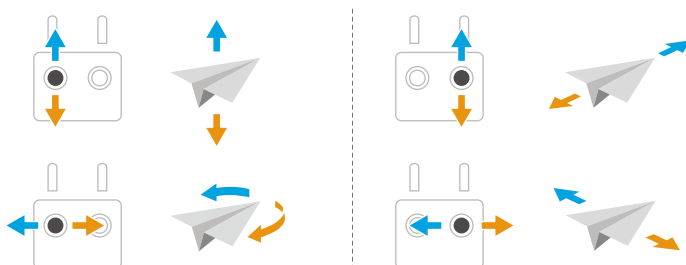

## Mode 3

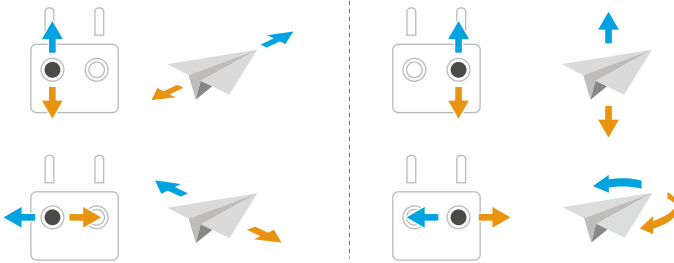

## Takeoff/Landing Procedures

- ⚠ • DO NOT launch the aircraft from your palm or while holding it with your hand.
- DO NOT operate the aircraft when the lighting is too bright or too dark to use the remote controller to operate flight. You are responsible for the correct adjustment of display brightness and amount of direct sunlight on the screen, as to avoid difficulty in viewing the screen clearly.

1. The pre-flight checklist is designed to help you fly safely. Go through the full pre-flight checklist before each flight.
2. Ensure the gimbal is locked and the footpads are facing down. Place the aircraft in an open, flat area with the rear of the aircraft facing the user. It is recommended to use with the included foldable landing pad.
3. Power on the remote controller and the aircraft.
4. Launch DJI Fly and enter the camera view.
5. Wait for the aircraft self-diagnostics to complete. If DJI Fly does not show any irregular warning, you can start the motors.
6. Push the throttle stick up slowly to take off.
7. To land, hover over a level surface and push the throttle stick down to descend.
8. After landing, push the throttle down and hold until the motors stop.
9. Power off the aircraft before the remote controller.

## Photos and Videos

Tap the shooting mode icon on the right side of the DJI Fly app to switch the lens mode. The gimbal will rotate automatically during the switch.

- 💡 • Single Lens mode only supports video recording.
  - Photo and video capture are not supported before takeoff.
- 

Press the Shutter/Record button on the remote controller or DJI Fly to take a photo or to start or stop recording.

In 360° mode:

- Rotate the left dial on the remote controller to move the view up or down.
  - Rotate the right dial to continuously zoom and adjust the FOV. You can also tap the icon on the right side of the app to switch zoom level, or tap and hold the icon and drag to zoom. When the view is facing downward and the zoom is set to the maximum FOV, the screen will display an asteroid view.
  - Rotate the right dial while pressing the C1 button to control the roll of the view.
- 

💡: To assign this function to a different button, go to the **Control** page in settings of DJI Fly, tap **Button Customization** to configure the settings.

---

## Intelligent Flight Modes



It is recommended to click the link below or scan the QR code to watch the tutorial video.



<https://www.dji.com/avata-360/video>

---

⚠️ Intelligent flight modes can only be used in 360° mode.

---

## FocusTrack

💡 When FocusTrack is enabled, the FOV is fixed at 104°.

---

## Spotlight

Spotlight supports two modes: Standard and Free.

- Standard: The aircraft nose always points toward the subject.

- **Free:** The camera view stays focused on the subject without pointing the aircraft nose at the subject.

In Free mode, the actual recorded footage is displayed in the bottom left corner of the screen. The main screen shows the view in front of the aircraft nose, and indicates the direction and distance of the subject. It is recommended to keep a moderate distance from the subject.

When the vision system is working normally, the aircraft will bypass or brake if an obstacle is detected, according to the obstacle avoidance action is set to **Bypass** or **Brake** in DJI Fly.

⚠ Obstacle avoidance is disabled in Sport mode.

Supported Subjects:

- Stationary subjects
- Moving subjects (only vehicles, boats, and people)

### Point of Interest (POI)

Allows the aircraft to fly around the subject.

The aircraft will bypass obstacles regardless of the flight modes or obstacle avoidance action settings in DJI Fly when the vision systems are working normally.

Supported Subjects:

- Stationary subjects
- Moving subjects (only vehicles, boats, and people)

### ActiveTrack

The aircraft follows the subject in Manual and Automatic Movement modes.

- **Manual:** Tap or slide the trace wheel to change tracking direction, and the aircraft will automatically fly from its current position 📍 along the generated trajectory to the selected tracking direction 📍 and keep tracking. Users can also manually adjust the tracking direction, height, and distance using the control sticks. Tap the FocusTrack Settings icon ⚙️ to set tracking parameters in the app.

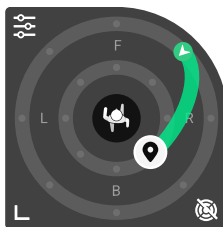

- Automatic Movement: Tap the AUTO icon  to enable or disable Automatic Movement. The aircraft continuously adjusts its flight path to follow the subject based on the flight environment.

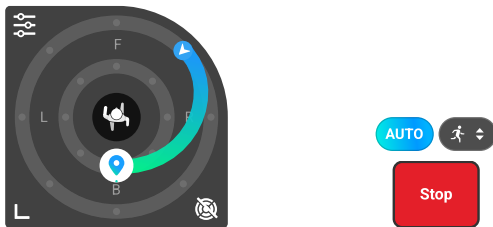

-  In Automatic Movement mode, the aircraft will follow the subject using the default tracking parameters of the app. Custom FocusTrack settings will not take effect. Pay attention to the flight environment and ensure flight safety.
- Moving a control stick or operating on the trace wheel, the aircraft will exit Automatic Movement mode.

The aircraft will bypass obstacles regardless of the flight modes or obstacle avoidance action settings in DJI Fly when the vision systems are working normally.

Supported Subjects:

Moving subjects (only vehicles, boats, and people). Auto mode only supports vehicle and people.

When the subject is a person, the aircraft can automatically detect different shooting scenes. Users can also tap the shooting scene icon  to manually switch shooting scene. Based on the selected scene, the aircraft applies corresponding tracking parameters.

In ActiveTrack, the supported distance and height ranges between the aircraft and subject are specified below.

Subject	People	Vehicles/Boats
Horizontal Distance	3-20 m	4-50 m
Height	0.5-20 m	0.5-50 m

-  The aircraft will fly to the supported distance and height range if the distance and height is out of range when ActiveTrack begins.
- It is recommended that the speed of the dynamic subject should not exceed 16 m/s; otherwise, the aircraft will not be able to track properly.



---



## Notice

---

- ⚠ • The aircraft cannot avoid moving subjects such as people, animals, or vehicles. When using FocusTrack, pay attention to the surrounding environment to ensure flight safety.
  - DO NOT use FocusTrack in areas with small or fine objects (e.g., tree branches or power lines), transparent objects (e.g., water or glass), or monochrome surfaces (e.g., white walls).
  - Always be prepared to press the Flight Pause button on the remote controller or tap  in DJI Fly in order to operate the aircraft manually in case any emergency situation occurs.
  - Be extra vigilant when using FocusTrack in any of the following situations:
    - ◆ The tracked subject is not moving on a level plane.
    - ◆ The tracked subject changes shape drastically while moving.
    - ◆ The tracked subject is out of sight for an extended period.
    - ◆ The tracked subject is in large monochrome areas such as snow-covered areas or deserts.
    - ◆ The tracked subject has a similar color or pattern to its surrounding environment.
    - ◆ The lighting is extremely dark (<5 lux) or bright (>100,000 lux).
  - Make sure to follow local privacy laws and regulations when using FocusTrack.
  - It is recommended to only track vehicles, boats, and people (but not children). Fly with caution when tracking other subjects.
  - For the supported moving subjects, vehicles refer to cars and small to medium-sized boats. DO NOT track a remote controlled car or boat.
  - The tracking subject may be inadvertently swapped to another subject if they pass nearby each other.
- 

## Using FocusTrack

Before enabling FocusTrack, make sure the flying environment is open and unobstructed with sufficient light.

Tap the FocusTrack icon  on the left of the camera view, or select the subject on the screen to enable FocusTrack. After enabling, tap the FocusTrack icon  again to exit.

---

-  During use, press the Flight Pause button on the remote controller to cancel the subject selection.
-

## QuickShots



QuickShots include multiple shooting modes. The aircraft automatically records according to the selected shooting mode and generates a short video.

### Notice

---

- ⚠ • Make sure there is sufficient space when using Boomerang. Allow a radius of at least 30 m (99 ft) around the aircraft and a space of at least 10 m (33 ft) above the aircraft.
  - Use QuickShots at locations that are clear of buildings and other obstacles. Make sure there are no people, animals, or other obstacles in the flight path.
  - Always pay attention to objects around the aircraft and use the remote controller to avoid collisions or the aircraft being obstructed.
  - DO NOT use QuickShots in any of the following situations:
    - ◆ When the subject is blocked for an extended period of time or outside the visual line of sight.
    - ◆ When the subject is in large monochrome areas such as snow-covered areas or deserts.
    - ◆ When the subject is similar in color or pattern with the surroundings.
    - ◆ When the subject is in the air.
    - ◆ When the subject is moving fast.
    - ◆ The lighting is extremely dark (<5 lux) or bright (>100,000 lux).
  - DO NOT use QuickShots in places close to buildings or where the GNSS signal is weak. Otherwise, the flight path will become unstable.
  - Make sure to follow local privacy laws and regulations when using QuickShots.
- 

### Using QuickShots

1. Tap the Shooting Mode icon on the right side of the camera view and select QuickShots .
2. After selecting one sub-mode, tap the plus icon or drag-select the subject on the screen. Then tap  to begin recording. The aircraft will record footage while performing a preset flight movement according to the option selected, and generate a video afterwards. The aircraft will fly back to its original position once recording is finished.

3. Tap  or press the Flight Pause button on the remote controller once. The aircraft will exit QuickShots immediately and hover.

## Panorama Footage Playback

Enter the Album in DJI Fly. Files marked with  are panoramic footage.

When playing back the footage, the original flight view is displayed by default. During playback, you can freely adjust the view by swiping the screen.

## 3.2 Immersive Motion Control

The steps below will help you operate the aircraft properly.

1. Go through the full pre-flight checklist before each flight.
2. Ensure the gimbal is locked and the footpads are facing down. Place the aircraft in an open, flat area with the rear of the aircraft facing the user. It is recommended to use with the included foldable landing pad.
3. Power on the goggles, remote control device, and the aircraft.
4. Wait until the aircraft status indicator blinks green slowly and put on the goggles.
5. Start the motors.
6. Check the flight liveview in the goggles to make sure that there are no warning prompts and that the GNSS signal is strong.
7. Press the lock button twice to start the aircraft motors, then press and hold to make the aircraft take off. The aircraft will ascend to approximately 1.2 m and hover.
8. Press and hold the lock button while the aircraft is hovering to land it automatically and stop the motors.
9. Power off the aircraft, goggles, and remote control device.

## Basic Flight



- It is recommended to watch the tutorial guide in the goggles before the first flight. Go to **Settings > Control > Motion Controller Flight Tutorial**.

Operate the aircraft by using the lock button, joystick, and accelerator of the DJI RC Motion 3.

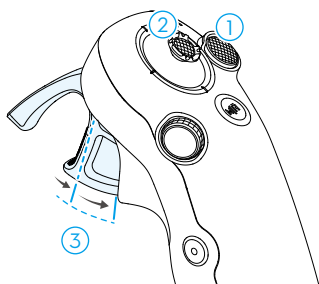

1. Use the lock button to control the takeoff, landing, and braking of the aircraft.
2. Move the joystick to make the aircraft ascend, descend, or move left or right horizontally\*.
3. There are two levels of pressure when pressing the accelerator. When gently pressing to the position in the middle of the first and second stop, you can feel a noticeable pause. Press the accelerator to different stops to control different actions of the aircraft.

\* When Easy ACRO is not enabled or the Easy ACRO action is selected as Slide.

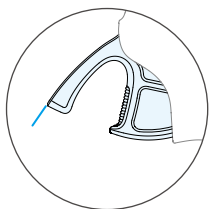

When the accelerator is not pressed, the aircraft will hover.

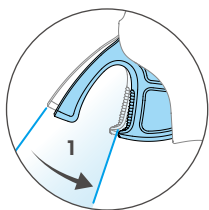

When gently pressing the accelerator to the first stop, you can adjust the aircraft orientation by tilting the motion controller vertically to the left or right. Note that the aircraft will not fly forward at this time.

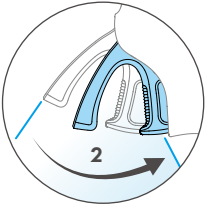

Press the accelerator to the second stop to make the aircraft to fly in the direction of the circle in the goggles.

## Taking Off, Braking, and Landing

**Takeoff:** Press the lock button twice to start the aircraft motors, then press and hold the button again to make the aircraft take off. The aircraft will ascend to approximately 1.2 m and hover.

**Braking:** Press the lock button during flight to make the aircraft brake and hover in place. Press again to resume flight control.

**Landing:** Press and hold the lock button while the aircraft is hovering to land it automatically and stop the motors.

- 💡 • After the aircraft motors have been started by double-pressing the lock button, slowly push the joystick up to make the aircraft take off.
  - When Easy ACRO is disabled, once the aircraft flies to the landing position, gently push the joystick downwards to land the aircraft. After landing, push the joystick down and hold in position until the motors stop.
- 
- ⚠️ • If an emergency occurs (such as a collision or the aircraft is out of control) during flight, pressing the lock button four times will trigger Stop Motors Mid-flight, which will stop the aircraft motors immediately. **The Stop Motors Mid-flight function will cause the aircraft to crash. Operate with caution.**
  - To ensure flight safety when using the motion controller, press the lock button once to brake and hover before operating the goggles. Failure to do so is a safety risk and may lead to the aircraft losing control or injury.

## Flying Forward and Backward

Press or push the accelerator of the motion controller to fly forward or backward. Apply more pressure when pressing or pushing to accelerate. Release to stop and hover.

Press the accelerator to the second stop to make the aircraft fly in the direction of the circle in the goggles.

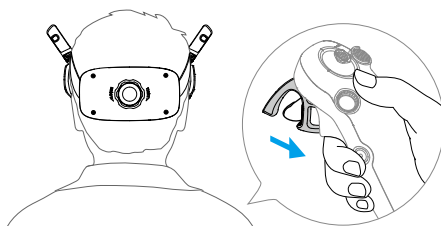
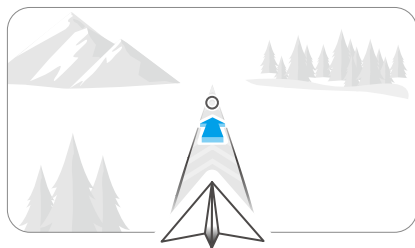

Push the accelerator forward to fly the aircraft in reverse.

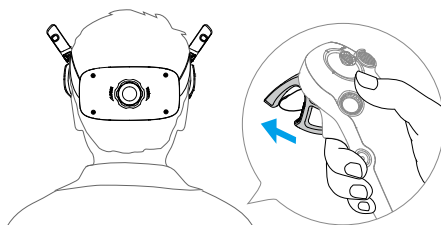
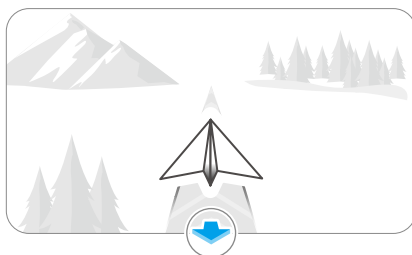

## Adjusting Aircraft Orientation

Gently press the accelerator to the first stop and simultaneously tilt the top of the motion controller in either direction to make the aircraft rotate. The greater the tilt angle of the

motion controller, the faster the aircraft will rotate. The circle in the goggles will move left and right and the flight liveview will change accordingly.



## Making the Aircraft Ascend or Descend at an Angle

When the aircraft needs to fly at an upward angle, press the accelerator to the second stop while simultaneously tilting the motion controller up.

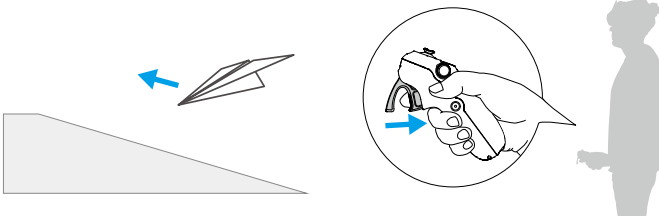

When the aircraft needs to fly at a downward angle, press the accelerator to the second stop while simultaneously tilting the motion controller down.

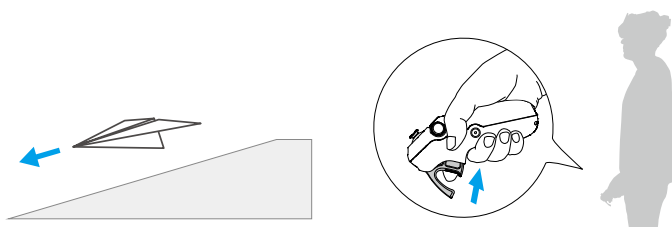

## Controlling the Gimbal and Camera

During flight, or when the accelerator is released and the aircraft is hovering:

- Single Lens mode: Tilt the motion controller up and down to control the tilt of the gimbal.

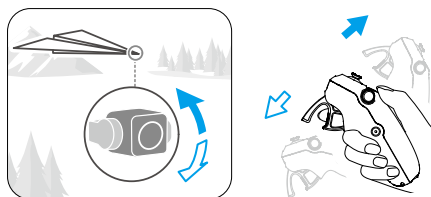

- 360° mode: Tilt the motion controller up and down to move the camera view accordingly.

The circle in the goggles will move up and down and the flight liveview will change accordingly.

- 
- ⚠ • Before takeoff or when using the lock button to trigger the aircraft to hover, the tilt of the gimbal/view cannot be controlled.
  - Rotate the dial on the motion controller to tilt the view during RTH and landing (above 2 m).
- 

## Head Tracking

Open the shortcut menu from the flight liveview, and click  to enable Head Tracking.

### 360° Mode

After enabling head tracking, the camera view will move with your head, without affecting the flight direction. At this time, you can still control the flight direction using the motion controller.



If the flight direction does not match your head orientation, Vision Assist automatically appears in the upper-left corner of the screen, showing the view in the flight direction. You can adjust this in the goggles display settings.

## Single Lens Mode

After enabling head tracking, the horizontal orientation of the aircraft and the gimbal tilt can be controlled using head movements during flight.

Once in Head Tracking mode, the motion controller will not be able to control the gimbal tilt, it will only control the aircraft. Users can still control the aircraft's heading by tilting the motion controller without pressing the accelerator.

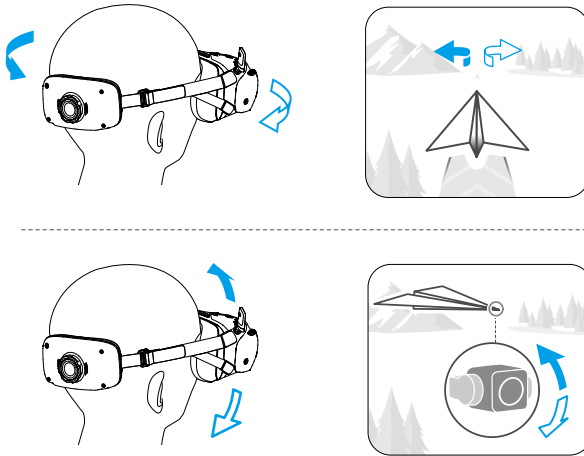

## Easy ACRO

Use the motion controller to control the aircraft or camera view to perform Easy ACRO actions such as flip, and 180° drift.

- ⚠ • Pay attention to surroundings and make sure there are no obstacles nearby before performing Easy ACRO actions.
- Easy ACRO is unavailable in the following situations:
  - ♦ The aircraft is taking off, hovering, landing, or returning to home;
  - ♦ The positioning performance is poor (GNSS and vision system are not available);

- The aircraft is in a buffer zone of a Restricted Zone or an Altitude Zone, or is approaching the Max Flight Distance.



- Zoom cannot be adjusted during Easy ACRO, and the FOV will remain as it was when Easy ACRO was enabled.
- Easy ACRO cannot be enabled in the following situations:
  - When recording video.
  - When Head Tracking is enabled.
  - When FocusTrack is enabled.
  - When used with DJI FPV Remote Controller 3.

1. Open the shortcut menu and select . The aircraft will be in Easy ACRO mode. View the selected action on the left side of liveview in the goggles.





2. Use the dial on the motion controller to switch between Easy ACRO actions.
3. When Easy ACRO is enabled, move the joystick to perform different Easy ACRO actions as shown below.

## Slide

Push the joystick up or down to make the aircraft ascend or descend.

Push the joystick left or right to make the aircraft move left or right horizontally.

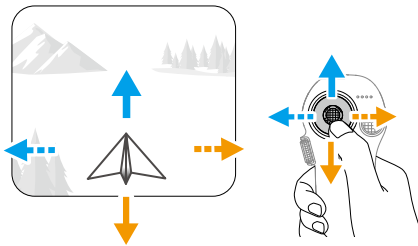

## 180° Drift

Push the joystick left or right to make the aircraft 180° drift left or right.

The aircraft will not respond when pushing the joystick up or down in this action mode.

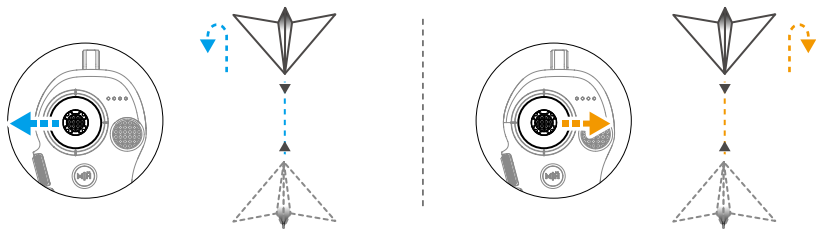

## Flip

Push the joystick up or down once, the camera view shows a forward or backward flip effect, but the aircraft does not flip.

Push the joystick left or right once, the camera view shows a left or right flip effect, but the aircraft does not flip.

## Juicy Flick

Push the joystick up once, the aircraft will rotate, showing a juicy flick effect in the camera view.

## Photos and Videos

Open the camera settings panel on the goggles to switch the lens mode. The gimbal will rotate automatically during the switch.

- 
- 💡 • Single Lens mode only supports video recording.
  - Photo and video capture are not supported before takeoff.
- 

Press the shutter/record button once to take a photo, or to start or stop recording.

In 360° mode:

- Tilt the motion controller up or down to move the camera view accordingly.
- Rotate the dial to adjust the zoom in or out. When the view is facing downward and the zoom is set to the maximum FOV, the screen will display an asteroid view.

## FocusTrack



Click the link or scan the QR code to watch the tutorial videos.



<https://www.dji.com/avata-360/video>

---

⚠ FocusTrack is only supported in 360° mode.

---

💡 When FocusTrack is enabled, the FOV is fixed at 104°.

---

You can fly the aircraft freely without pointing the aircraft nose at the subject. The camera view stays focused on the subject.

When the vision system is working normally, the aircraft will bypass or brake if an obstacle is detected, according to the obstacle avoidance action is set to **Bypass** or **Brake** in DJI Fly.

---

⚠ Obstacle avoidance is disabled in Sport mode.

---

Supported Subjects:

- Stationary subjects
- Moving subjects (only vehicles, boats, and people)

## Notice

---

- ⚠ • The aircraft cannot avoid moving subjects such as people, animals, or vehicles. When using FocusTrack, pay attention to the surrounding environment to ensure flight safety.
- DO NOT use FocusTrack in areas with small or fine objects (e.g., tree branches or power lines), transparent objects (e.g., water or glass), or monochrome surfaces (e.g., white walls).
- Always be prepared to press the lock button in an emergency to manually control the aircraft.
- Be extra vigilant when using FocusTrack in any of the following situations:
  - ◆ The tracked subject is not moving on a level plane.
  - ◆ The tracked subject changes shape drastically while moving.
  - ◆ The tracked subject is out of sight for an extended period.

- The tracked subject is in large monochrome areas such as snow-covered areas or deserts.
  - The tracked subject has a similar color or pattern to its surrounding environment.
  - The lighting is extremely dark (<5 lux) or bright (>100,000 lux).
  - Make sure to follow local privacy laws and regulations when using FocusTrack.
  - It is recommended to only track vehicles, boats, and people (but not children). Fly with caution when tracking other subjects.
  - For the supported moving subjects, vehicles refer to cars and small to medium-sized boats. DO NOT track a remote controlled car or boat.
  - The tracking subject may be inadvertently swapped to another subject if they pass nearby each other.
- 

## Using FocusTrack

Before enabling FocusTrack, make sure the flying environment is open and unobstructed with sufficient light.

- **When the aircraft is hovering after pressing the lock button on the motion controller:**
  1. Open the shortcut menu from the flight liveview, and select [•] to enable FocusTrack.
  2. Tap + or drag to select the subject on the screen.
  3. Press the lock button again to unlock the aircraft and resume flying.
- **When the aircraft is not locked during flight:**
  1. Press and hold the dial on the side of the motion controller to enable FocusTrack.
  2. Press the dial to select the subject.

During tracking, press the shutter/record button to start recording. The actual recorded footage is displayed in the upper-left corner of the screen. The main screen shows the view in front of the aircraft nose, and indicates the direction and distance of the subject. It is recommended to keep a moderate distance from the subject.

To exit FocusTrack, tap [•] again, or press and hold the dial.



- During FocusTrack, press the dial on the side of the motion controller to cancel the selected subject.
- Open the goggles menu, go to **Settings > Control**, and you can assign the press-and-hold action of the dial to other functions.

- For more stable footage, open the goggles menu, go to **Settings > Control**, and switch the gimbal mode to Follow.

## Panorama Footage Playback

Enter the Album in the goggles. Files marked with  are panoramic footage.

When playing back footage on the goggles, Free View is enabled by default. Turn your head to view the scene from different perspectives.

Open the playback menu and switch to Camera FOV, this locks the framing to the original flight view.

### Controlling Video Playback

Using the 5D button:

- Press the button to pause or resume playback.
- Push the button left or right to adjust the progress bar.
- Push the button backward to enter playback settings and adjust the screen brightness or volume.

Using AR cursor:

- Press the accelerator to pause or resume playback, push the accelerator forward to exit.
- Move the cursor left or right while pressing the accelerator down to adjust the progress bar.
- Move the cursor to the arrow at the top of the screen, then press down the accelerator to enter playback settings and adjust the screen brightness or volume.

## 3.3 Video Suggestions and Tips

1. Select the desired gimbal operation mode in DJI Fly.
2. It is recommended to take photos or record videos when flying in Normal or Cine mode.
3. DO NOT fly in bad weather such as on rainy or windy days.
4. Choose the camera settings that best suit your needs.
5. Perform flight tests to establish flight routes and preview scenes.
6. Push the control sticks gently to ensure smooth and stable movement of the aircraft.

# Aircraft

---



## 4 Aircraft

### 4.1 Flight Mode

When using the DJI RC 2 remote controller, flight modes can be switched between Normal, Sport, and Cine using the flight mode switch on the remote controller.

When using the motion controller, flight modes can be switched between Normal and Sport using the mode button on the motion controller.

**Normal Mode:** Normal mode is suitable for most flight scenarios. The aircraft can hover precisely, fly stably, and use Intelligent Flight Modes.

**Sport Mode:** The maximum horizontal flight speed of the aircraft will be higher when compared with Normal mode. Note that obstacle avoidance is disabled in Sport mode.

**Cine Mode:** Cine mode is based on Normal mode with a limited flight speed, making the aircraft more stable during recording.

The aircraft automatically changes to Attitude (ATTI) mode when the vision system is unavailable or disabled and the GNSS signal is weak or the compass experiences interference. In ATTI mode, the aircraft may be more easily affected by its surroundings. Environmental factors such as wind can result in horizontal drift of the aircraft, which may present hazards, especially when flying in confined spaces. The aircraft will not be able to hover or brake automatically, therefore the pilot should land the aircraft as soon as possible to avoid accidents.



- The flight modes are only effective for manual flight.



- The vision system is disabled in Sport mode, which means the aircraft cannot sense obstacles on its route automatically. You must stay alert to the surrounding environment and control the aircraft to avoid obstacles.
  - The maximum speed and braking distance of the aircraft significantly increase in Sport mode. A minimum braking distance of 30 m is required in windless conditions.
  - A minimum braking distance of 10 m is required in windless conditions while the aircraft is ascending and descending in Sport mode or Normal mode.
  - The responsiveness of the aircraft significantly increases in Sport mode, which means a small control stick movement on the remote controller translates into the aircraft moving a large distance. Make sure to maintain adequate maneuvering space during flight.
  - You may experience shaking in videos recorded in Sport mode.
-



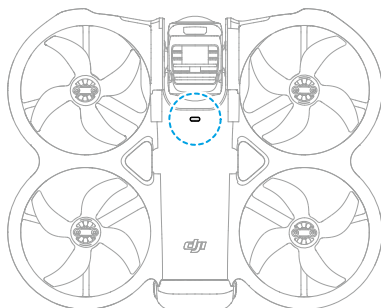

## 4.2 Aircraft Status Indicators







When the aircraft is powered on, but the motors are not running, the aircraft status indicator will display the current status of the aircraft.

### Aircraft Status Indicator Descriptions

#### Normal States

	Blinks red, yellow, and green alternately	Powering on and performing self-diagnostic tests
	Blinks yellow four times	Warming up
	Blinks green slowly	GNSS enabled
	Blinks green twice repeatedly	Vision systems enabled
	Blinks yellow slowly	GNSS and vision system disabled (ATTI mode enabled)

#### Warning States

	Blinks yellow quickly	Remote controller signal lost
	Blinks red slowly	Takeoff is disabled (e.g., low battery) <sup>[1]</sup>
	Blinks red quickly	Critically low battery
	Solid red	Critical error
	Blinks red and yellow alternately	Compass calibration required

[1] If the aircraft cannot take off while the status indicator is blinking red slowly, view the warning prompt in DJI Fly or the goggles.

## 4.3 Return to Home

Carefully read the contents of this section to ensure you are familiar with the behavior of the aircraft in Return-to-Home (RTH).

The Return to Home (RTH) function will automatically fly the aircraft back to the last recorded Home Point. RTH can be triggered in three ways: the user actively triggers RTH, the aircraft has low battery, or the remote controller signal has been lost (Failsafe RTH is triggered). If the aircraft has recorded the Home Point successfully and the positioning system is functioning normally, when the RTH function is triggered, the aircraft will automatically fly back and land at the Home Point.



- **Home Point:** The Home Point will be recorded at takeoff as long as the aircraft has a strong GNSS signal  26 or the lighting is sufficient. After the Home Point is recorded, DJI Fly will issue a voice prompt. If it is necessary to update the Home Point during a flight (such as if you have changed your position), the Home Point can be manually updated in \*\*\* > **Safety** page in DJI Fly.

When the aircraft is used with the DJI RC 2 remote controller, [Dynamic Home Point](#) is available.



- To ensure safety, the gimbal will automatically rotate to 360° mode during RTH. Switching to Single Lens mode is not supported during RTH.

During RTH, the AR RTH route will be displayed on the camera view, helping you to view the return path and ensure flight safety. The camera view also displays the AR Home Point. When the aircraft reaches the area above the Home Point, the camera view will automatically flip downwards. The AR aircraft shadow will appear in the camera view when the aircraft is approaching the ground, enabling you to control the aircraft to land more accurately in your preferred location.

The AR Home Point, AR RTH route, and AR aircraft shadow will be displayed in the camera view by default. The display can be changed in \*\*\* > **Safety** > **AR Settings**.



- The goggles do not support displaying the AR RTH route or AR aircraft shadow.
- The AR RTH route is only used for reference, and may deviate from the actual flight route in different scenarios. Always pay attention to the liveview on the screen during RTH. Fly with caution.
- During RTH, the aircraft will automatically adjust the camera view toward the RTH route by default. Manually adjusting the view will stop automatic adjustment, which may prevent the AR RTH route from being viewed.

## Notice

---

- ⚠ • The aircraft may not be able to return to the Home Point as normal if the positioning system is functioning abnormally. During Failsafe RTH, the aircraft may enter ATTI mode and land automatically if the positioning system is functioning abnormally.
- When there is no GNSS, do not fly over water surfaces, buildings with glass surface, or in scenarios where the altitude above the ground is greater than 30 meters. If the positioning system is functioning abnormally, the aircraft will enter ATTI mode.
- It is important to set a suitable RTH altitude before each flight.
- The aircraft cannot sense obstacles during RTH if the environment conditions are not suitable for the sensing system.
- GEO zones may affect the RTH. Avoid flying near GEO zones.
- The aircraft may not be able to return to a Home Point if the wind speed is too high. Fly with caution.
- Pay extra attention to small or fine objects (such as tree branches or power lines) or transparent objects (such as water or glass) during RTH. Exit RTH and control the aircraft manually in an emergency.
- Set Advanced RTH as **Preset** if there are power lines or transmission towers that the aircraft cannot bypass on the RTH path and make sure the RTH Altitude is set higher than all obstacles.
- The aircraft will brake and return to home according to the latest settings if the **Advanced RTH** settings are changed during RTH.
- If the max altitude is adjusted below the current altitude during RTH, the aircraft will descend to the max altitude first and then continue returning to home.
- The RTH Altitude cannot be changed during RTH.
- If there is a large difference between the current altitude and the RTH altitude, the amount of battery power used cannot be calculated accurately due to wind speed differences at different altitudes. Pay extra attention to the battery power prompts and warning prompts in the camera view.
- When the remote controller signal is normal during Advanced RTH, the pitch stick can be used to control the flight speed, but the orientation and altitude cannot be controlled and the aircraft cannot be controlled to fly to the left or right. Constantly pushing the pitch stick to accelerate will increase the battery power consumption speed. The aircraft cannot bypass obstacles if the flight speed exceeds the effective sensing speed. The aircraft will brake and hover in

place and exit RTH if the pitch stick is pushed all the way down. The aircraft can be controlled after the pitch stick is released.

- If the aircraft reaches the altitude limit of the aircraft current location or of the Home Point while it is ascending during Preset RTH, the aircraft stops ascending and returns to the Home Point at the current altitude. Pay attention to flight safety during RTH.
  - If the Home Point is within the Altitude Zone but the aircraft is not in the Altitude Zone, when the aircraft reaches the Altitude Zone it will descend below the altitude limit, which may be lower than the set RTH altitude. Fly with caution.
  - The aircraft will exit RTH if the surrounding environment is too complex to complete RTH, even if the sensing system is working properly.
  - RTH cannot be triggered during auto landing.
  - If RTH is triggered when the aircraft is playing back footage, playback will automatically exit.
  - During RTH, only video recording is supported. Adjusting recording settings or taking photos is not supported.
- 

## Advanced RTH

When Advanced RTH is triggered, the aircraft will automatically plan the best RTH path, which will be displayed in DJI Fly and will be adjusted according to the environment. During RTH, the aircraft will adjust the flight speed automatically according to environmental factors such as the wind speed, wind direction, and obstacles.

---

 The goggles do not support displaying the RTH path.

---

If the signal between the remote control device and the aircraft is good, you can exit RTH using the following methods:

- Remote Controller: Tap  in DJI Fly or press the RTH button on the remote controller.
- Motion Controller: Press the lock button.

After exiting RTH, you will regain control of the aircraft.

## Trigger Method

### The user actively triggers RTH

During flight, you can trigger RTH using the following methods:

- Remote Controller: Press and hold the RTH button on the remote controller, or tapping  on the left side of the camera view and then pressing and holding the RTH icon.
- Motion Controller: Press and hold the mode button.

If the remote controller signal is lost during RTH, the aircraft will continue the RTH procedure regardless of the preset Signal Lost Action.

### Aircraft low battery

During flight, if the battery level is low and only sufficient to fly to the Home Point, a warning prompt will appear in the camera view. If you tap to confirm RTH or do not take action before the countdown ends, the aircraft will automatically initiate low battery RTH.

If you cancel the low battery RTH prompt and continue flying the aircraft, the aircraft will land automatically when the current battery level can only support the aircraft long enough to descend from its current altitude.

Auto landing cannot be cancelled but you can still fly the aircraft horizontally by moving the pitch stick and roll stick, and change the descent speed of the aircraft by moving the throttle stick. Fly the aircraft to a suitable place for landing as soon as possible.



- When the Intelligent Flight Battery battery level is too low and there is not enough power to return home, land the aircraft as soon as possible. Delayed action will initiate progressive thrust decay, potentially escalating to uncontrolled descent upon total depletion. This may cause aircraft destruction, third-party property damage, or personal injury.
  - DO NOT keep pushing the throttle stick upward during auto landing. Otherwise, the aircraft will experience progressive thrust decay and even crash after the battery power is completely depleted.
- 

### Loss of remote controller signal

When the remote controller signal is lost for more than 6 seconds, the aircraft will automatically initiate Failsafe RTH if the Signal Lost Action is set to RTH. The action can also be set to Hover or Landing.

When the lighting and environment conditions are suitable for the vision system, DJI Fly will display the RTH path that was generated by the aircraft before the signal was lost. The aircraft will start RTH using Advanced RTH according to the RTH settings. The aircraft will remain in RTH even if the remote controller signal is restored. DJI Fly will update the RTH path accordingly.

When the lighting and environment conditions are unsuitable for the vision system, the aircraft will brake and hover, then enter Original Route RTH.

- If the RTH distance (the horizontal distance between the aircraft and the Home Point) is farther than 50 m, the aircraft adjusts its orientation and flies backward for 50 m on its original flight route before entering Preset RTH.
- If the RTH distance is farther than 5 m but less than 50 m, the aircraft adjusts its orientation and flies straight horizontally back to the home point at the current altitude.
- The aircraft lands immediately if the RTH distance is less than 5 m.

## RTH Procedure

After Advanced RTH is triggered, the aircraft brakes and hovers in place.

- **When the environment or lighting conditions are suitable for the vision system:**
  - ♦ The aircraft will adjust its orientation to the Home Point, plan the best path according to the RTH settings and then return to the Home Point if GNSS was available when takeoff.
  - ♦ If GNSS was unavailable and only the vision system was working when takeoff, the aircraft will adjust its orientation to the Home Point, plan the best path according to the RTH settings and then return to the position with strong GNSS signal based on the RTH settings. It will approximately follow the outbound trajectory back to the vicinity of the home point. At this time, pay attention to the app prompts and choose whether to let the aircraft automatically RTH and land or to manually control the RTH and landing.

### **Pay attention if GNSS was unavailable when takeoff:**

- ◊ Make sure that the obstacle avoidance is enabled.
- ◊ DO NOT fly in narrow spaces and the environmental wind speed should be less than 3 m/s.
- ◊ Fly to the open area and stay at least 10 meters away from any obstacles quickly after takeoff, otherwise, the aircraft may not be able to return to home. During flight, avoid flying over water surfaces until reaching an area with strong GNSS signal. The altitude above the ground should be greater than 2 meters and less than 30 meters, otherwise, the aircraft may not be able to return to the home point. If the aircraft enters ATTI mode before reaching the area with strong GNSS signal, the home point will be invalidated.
- ◊ If the vision positioning is not available during flight, the aircraft cannot return to the home point. Pay attention to the environment according to the App voice prompts to prevent collisions.

- ◊ When the aircraft returns to the vicinity of the takeoff point and the App prompts when the current environment is complex, please confirm whether to continue flying:
  - You need to confirm whether the flight path is correct and pay attention to flight safety.
  - You need to confirm whether the lighting condition is sufficient for the vision system. If not, the aircraft may exit RTH. Forcing the aircraft to continue RTH or flight may cause it to enter ATTI mode.
- ◊ After confirmation, the aircraft will continue to return to the home point at a low speed. If an obstacle appears on the return path, the aircraft will brake and may exit RTH.
- ◊ This RTH process does not support dynamic obstacle detection (including pedestrians, etc.) and does not support obstacle detection in textureless scenes such as glass or white walls.
- ◊ This RTH process requires the ground and nearby environments (such as walls) to have rich textures and no dynamic changes.
- **When the environment or lighting conditions are not suitable for the vision system:**
  - ♦ If the RTH distance is further than 5 meters, the aircraft will return to home according to the **Preset**.
  - ♦ The aircraft lands immediately if the RTH distance is less than 5 m.

## RTH Settings

RTH settings are available for Advanced RTH.

- Remote Controller: Go to the camera view in DJI Fly, tap \*\*\* > **Safety**, and scroll to **Advanced RTH**.
- Goggles: Go to **Settings > Safety > Advanced RTH**.

## Optimal

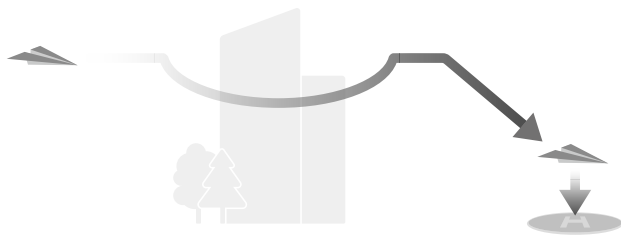



- If the lighting is sufficient and the environment is suitable for the vision system, the aircraft will automatically plan the optimal RTH path and adjust the altitude according to environmental factors, such as obstacles and transmission signals, regardless of the RTH Altitude setting. The optimal RTH path means the aircraft will travel the shortest distance possible to reduce the amount of battery power used and to increase flight time.
- If the lighting is insufficient or the environment is not suitable for the vision system, the aircraft will perform Preset RTH based on the RTH Altitude setting.

**Preset**



RTH Distance/Altitude		Suitable Lighting and Environment Conditions	Unsuitable Lighting and Environment Conditions
RTH distance > 50 m	Current altitude < RTH altitude	The aircraft will plan the RTH path, fly to an open area while bypassing obstacles, ascend to the RTH Altitude, and return to home using the best path.	The aircraft will ascend to the RTH altitude, and fly to the Home Point in a straight line at the RTH altitude. <sup>[1]</sup>
	Current altitude ≥ RTH altitude	The aircraft will return to home using the best path at the current altitude.	The aircraft will fly to the Home Point in a straight line at the current altitude. <sup>[1]</sup>
RTH distance is within 5-50 m			The aircraft will fly to the Home Point in a straight line at the current altitude. <sup>[2]</sup>

[1] If the forward-facing LiDAR detects an obstacle ahead, the aircraft will ascend to avoid the obstacle. It will stop climbing once the path ahead is clear and then continue to RTH. If the obstacle height exceeds the altitude limit, the aircraft will brake and hover, and the user will need to take control.

[2] If the forward-facing LiDAR detects an obstacle ahead, the aircraft will brake and hover, and the user will need to take control.

When the aircraft is approaching the Home Point, if the current altitude is higher than the RTH altitude, the aircraft will intelligently decide whether to descend while flying forward according to the surrounding environment, lighting, the set RTH altitude, and the current altitude. When the aircraft reaches the area above the Home Point, the current altitude of the aircraft will not be lower than the set RTH altitude.

The RTH plans for different environments, RTH trigger methods, and RTH settings are as follows:

RTH Trigger Method	Suitable Lighting and Environment Conditions (The aircraft can bypass obstacles and GEO zones)	Unsuitable Lighting and Environment Conditions
The user actively triggers RTH	The aircraft will perform RTH based on the RTH setting: <ul style="list-style-type: none"> <li>• Optimal</li> <li>• Preset</li> </ul>	Preset (The aircraft can ascend to bypass obstacles and GEO zones)
Aircraft low battery		Original route RTH, Preset RTH will be executed when the signal is restored (The aircraft can bypass GEO zones and will brake and hover if there is obstacle)
Loss of remote controller signal		

## Dynamic Home Point

When the aircraft is used with the DJI RC 2 remote controller, Dynamic Home Point is available.

When the GNSS signal of the remote controller is strong, enable Dynamic Home Point through any of the following methods, and the Home Point will be continuously updated to the remote controller location.

- In camera view, tap  > Update Home Point > Dynamic Home Point > Update.
- In camera view, tap \*\*\* > Safety > Update Home Point > Dynamic Home Point > Update.

When Dynamic Home Point is enabled, the RTH icon will turn blue. After RTH is triggered, the aircraft will return near the Home Point, exit RTH, and hover. Users can control the aircraft.

- 
- ⚠ • After enabling Dynamic Home Point for the first time, if the GNSS signal of the remote controller is weak, the dynamic Home Point may not be available.

- Use the Dynamic Home Point function in an open environment with a strong GNSS signal. Otherwise, the Home Point will have a large deviation from the actual remote controller location.
  - Once the dynamic Home Point is available, if the GNSS signal of the remote controller is weak, the Home Point will remain at the last successfully updated location. When RTH is triggered, check if the Home Point location is the latest remote controller location.
- 

## Landing Protection

During RTH, landing protection activates once the aircraft begins to land.

The specific performance of the aircraft is as follows:

- If the ground is determined suitable for landing, the aircraft will land directly.
  - If the ground is determined unsuitable for landing, the aircraft will hover and wait for pilot confirmation.
  - If landing protection is not operational, DJI Fly will display a landing prompt when the aircraft descends to 0.5 m from the ground. Tap **Confirm** or push the throttle stick all the way down and hold for one second, and the aircraft will land.
- 



- After reaching the area above the Home Point, the aircraft will land precisely on the takeoff point. Performing a precision landing is subject to the following conditions:
    - ♦ The Home Point must be recorded upon takeoff and must not be changed during flight.
    - ♦ During takeoff, the aircraft must vertically ascend at least 7 m before moving horizontally.
    - ♦ The Home Point terrain features must remain largely unchanged.
    - ♦ The terrain features of the Home Point must be sufficiently distinctive. Terrain such as a snow-covered field is not suitable.
    - ♦ The lighting conditions must not be too bright or too dark.
  - During landing, movement of any other control stick apart from the throttle stick will be regarded as giving up precision landing, and the aircraft will descend vertically.
-

## 4.4 Sensing System

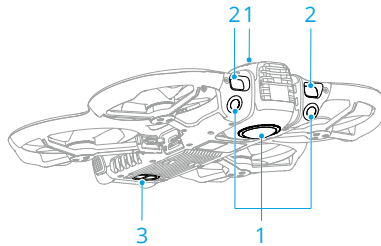

1. Omnidirectional Vision System
2. Forward-Facing LiDAR
3. 3D Infrared Sensing System

The omnidirectional vision system works best with adequate lighting and clearly marked or textured obstacles. The omnidirectional vision system will activate automatically when the aircraft is in Normal or Cine mode and obstacle avoidance action is set to **Bypass** or **Brake**. The positioning function is applicable when GNSS signals are unavailable or weak.

- 
- ⚠ • The omnidirectional vision system is only available in 360° mode, providing omnidirectional obstacle avoidance. In Single Lens mode, the aircraft supports forward obstacle avoidance only. Fly with caution.
  - Obstacle avoidance is unavailable when switching lens modes. Only switch lens modes in a safe flying environment.
- 
- 💡 • When Vision Positioning and Obstacle Avoidance is disabled, the aircraft relies only on GNSS to hover, omnidirectional obstacle avoidance is unavailable, and the aircraft will not automatically decelerate during descent close to the ground. Extra caution is required when Vision Positioning and Obstacle Avoidance is disabled.
  - Disabling Vision Positioning and Obstacle Avoidance takes effect only when flying manually, and will not take effect when using RTH, auto landing, or using Intelligent Flight Modes.
  - Vision Positioning and Obstacle Avoidance can be temporarily disabled in clouds and fog or when an obstacle is detected when landing. Keep Vision Positioning and Obstacle Avoidance enabled in regular flight scenarios. Vision Positioning and Obstacle Avoidance is enabled by default after restarting the aircraft.
-

## Notice

---

- ⚠ • Pay attention to the flight environment. The sensing system only works in certain scenarios and cannot replace human control and judgment. During a flight, always pay attention to the surrounding environment and the warnings in DJI Fly, and be responsible for and maintain control of the aircraft at all times.
- If there is no GNSS available, the downward vision system will assist with aircraft positioning, and works best when the aircraft is at an altitude from 0.5 m to 30 m. Extra caution is required if the altitude of the aircraft is above 30 m as the vision positioning performance may be affected.
- The downward vision system may not work properly when the aircraft is flying near water. Therefore, the aircraft may not be able to actively avoid water below it when landing. It is recommended to maintain flight control at all times, make reasonable judgments based on the surrounding environment, and avoid over-relying on the downward vision system.
- The vision system cannot accurately identify large structures with frames and cables, such as tower cranes, high-voltage transmission towers, high-voltage transmission lines, cable-stayed bridges, and suspension bridges.
- The vision system cannot work properly near surfaces without clear pattern variations or where the lighting is too weak or too strong. The vision system cannot work properly in the following situations:
  - ◆ Flying near monochrome surfaces (e.g., pure black, white, red, or green).
  - ◆ Flying near highly reflective surfaces.
  - ◆ Flying near water or transparent surfaces.
  - ◆ Flying near moving surfaces or objects.
  - ◆ Flying in an area with frequent and drastic lighting changes.
  - ◆ Flying near extremely dark (<1 lux) or bright (>100,000 lux) surfaces.
  - ◆ Flying near surfaces that strongly reflect or absorb infrared waves (e.g., mirrors, asphalt pavements).
  - ◆ Flying near surfaces without clear patterns or textures.
  - ◆ Flying near surfaces with repeating identical patterns or textures (e.g., tiles with the same design).
  - ◆ Flying near obstacles with small surface areas (e.g., tree branches, and power lines).
- Keep the sensors clean at all times. DO NOT scratch or tamper with the sensors. DO NOT use the aircraft in dusty or humid environments.

- The vision system cameras may need to be calibrated after being stored for an extended period. A prompt will appear in DJI Fly and calibration will be performed automatically.
  - DO NOT fly when it is rainy, smoggy, or the visibility is lower than 100 m.
  - DO NOT obstruct the sensing system.
  - Check the following each time before takeoff:
    - ♦ Make sure there are no stickers or any other obstructions over the glass of the sensing system.
    - ♦ Use a soft cloth if there is any dirt, dust, or water on the glass of the sensing system. DO NOT use any cleaning product that contains alcohol.
    - ♦ Contact DJI Support if there is any damage to the lenses of the sensing system.
  - The forward-facing LiDAR cannot detect obstacles with a reflectivity of less than 10% or reflective objects such as glass.
  - The forward-facing LiDAR cannot work properly in environments with too strong lighting (>20,000 lux).
- 

## 4.5 Advanced Pilot Assistance Systems

The Advanced Pilot Assistance Systems (APAS) feature is available in Normal mode and Cine mode. When APAS is enabled, the aircraft will continue to respond to your commands and plan its path according to both control stick inputs and the flight environment. APAS makes it easier to avoid obstacles, obtain smoother footage, and give a better flying experience.

When APAS is enabled, the aircraft can be stopped by pressing the flight pause button on the remote controller, or pressing the lock button on the motion controller. The aircraft brakes and hovers for three seconds and awaits further pilot commands.

To enable APAS,

- Remote Controller: Open DJI Fly, go to \*\*\* > **Safety** > **Manual Obstacle Avoidance**, and select **Bypass**.
- Goggles: Go to **Settings** > **Safety** > **Obstacle Avoidance**, and select **Bypass**.

## Notice

---

- ⚠ • Make sure to use APAS when the vision system is available. Make sure there are no people, animals, objects with small surface areas (e.g., tree branches), or transparent objects (e.g., glass or water) along the desired flight path.
  - Make sure to use APAS when the downward vision system is available or the GNSS signal is strong. APAS may not function properly when the aircraft is flying over water or snow-covered areas.
  - Be extra cautious when flying in extremely dark (<300 lux) or bright (>100,000 lux) environments.
  - Pay attention to DJI Fly and make sure APAS is working normally.
  - APAS may not function properly when the aircraft is flying near flight limits or in a GEO zone.
  - When the lighting becomes insufficient and the vision system is partially unavailable, the aircraft will switch from bypassing obstacles to braking and hovering. You need to center the control stick and then to continue controlling the aircraft.
- 

## Landing Protection

If obstacle avoidance action is set to **Bypass** or **Brake**, Landing Protection will be activated when you push the throttle stick down to land the aircraft. Landing Protection is enabled once the aircraft begins to land.

- If the ground is determined to be suitable for landing, the aircraft will land directly.
- If the ground is determined to be unsuitable for landing, the aircraft will hover when the aircraft descends to a certain height above ground. Push down on the throttle stick for at least five seconds, and the aircraft will land without obstacle avoidance.

## 4.6 Vision Assist

The vision assist view, powered by the vision systems, updates the view based on the flight direction to help users navigate and observe obstacles during flight. Swipe left on the attitude indicator, right on the mini map, or tap the icon in the lower right corner of the attitude indicator to switch to the vision assist view.

- ⚠ • When using vision assist, the quality of the video transmission may be lower due to transmission bandwidth limits, cell phone performance, or the video transmission resolution of the screen on the remote controller.

- It is normal for components of the aircraft to appear in the vision assist view.
  - It is normal that image seams or brightness differences may occur in the vision assist view.
  - Vision assist should be used for reference only. Glass walls and small objects such as tree branches, electric wires, and kite strings cannot be displayed accurately.
  - Vision assist is not available when the aircraft has not taken off or when the video transmission signal is weak.
- 



1. Tap the view direction icon.
2. Tap the arrow to switch between different directions of the vision assist view. Tap the arrow again to lock the direction.

Tap the center of the screen to maximize the vision assist view.

- ⚠ • When the direction is not locked, the vision assist view automatically switches to the current flight direction. Tap any other directional arrow to temporarily switch the view. The view will automatically return to the flight direction after a short period.
  - During takeoff and landing, if the gimbal is locked, the vision assist view is locked to the forward direction by default and cannot be changed.
- 

## Collision Warning

When an obstacle in the current view direction is detected, the vision assist view shows a collision warning. The color of the warning is determined by the distance between the obstacle and the aircraft. Yellow and red colors indicate the relative distance ranging from far to near.

- 💡 • The FOV of the vision assist in all directions is limited. It is normal not to see obstacles in the field of view during a collision warning.
-



- The collision warning is not controlled by the **Display Radar Map** switch and remains visible even when the radar map is switched off.
- A collision warning appears only when the vision assist view is displayed in the small window.

## 4.7 Propellers

### Attaching/Detaching the Propellers

Attach the marked propellers to the marked motors, and the unmarked propellers to the unmarked motors. Use the screws provided in the packaging of the propellers to secure the propellers. Make sure to tighten the screws.

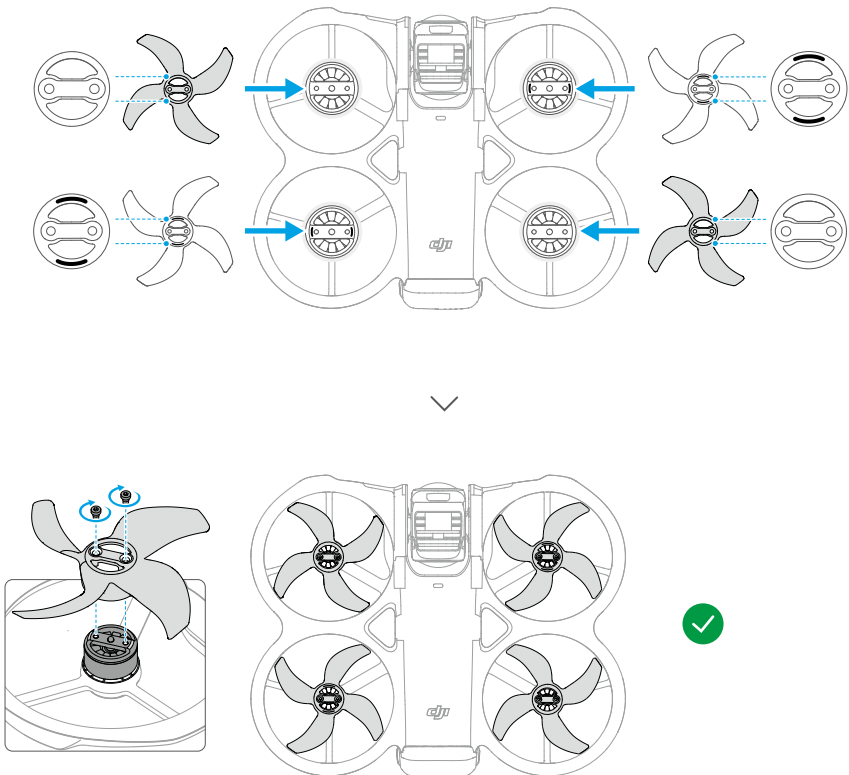

## Notice

---

- ⚠ • Make sure to only use the screwdriver from the aircraft package for mounting propellers. Using other screwdrivers may damage the screws.
  - Make sure to keep the screws vertical while tightening them. The screws should not be at a tilted angle to the mounting surface. After installation is complete, check whether the screws are flush and rotate the propellers to check for any abnormal resistance.
  - Check to make sure the screws on the propellers are tightened after every 30 hours of flying time (approx. 60 flights).
  - The screwdriver is only for mounting the propellers. DO NOT use the screwdriver to disassemble the aircraft.
  - If a propeller is broken, remove the propeller and screws on the corresponding motor and discard them.
  - The propeller blades are sharp. Handle with care to avoid personal injury or propeller deformation.
  - Make sure that the propellers and motors are installed securely before each flight.
  - Only use official DJI propellers. DO NOT mix propeller types.
  - Propellers are consumable components. Purchase additional propellers if necessary.
  - Make sure that all propellers are in good condition before each flight. DO NOT use aged, chipped, or broken propellers. Clean the propellers with a soft, dry cloth if there is any foreign matter attached.
  - To avoid injury, stay away from rotating propellers or motors.
  - To avoid damaging the propellers, place the aircraft correctly during transportation or storage. DO NOT squeeze or bend the propellers. If propellers are damaged, the flight performance may be affected.
  - Make sure the motors are mounted securely and rotating smoothly. If the motor overloads or stalls during flight, land immediately.
  - DO NOT attempt to modify the structure of the motors.
  - DO NOT touch or let hands or body parts come in contact with the motors after flight, as they may be hot.
  - DO NOT block any of the ventilation holes on the motors or the body of the aircraft.
  - Make sure the ESCs sound normal when powered on.
-

## 4.8 Intelligent Flight Battery

### Notice

- 
-  • Read and strictly follow the instructions in this manual, in the *Safety Guidelines* and on the battery stickers before using the battery. You shall take full responsibility for all operations and usage.
- 
1. DO NOT charge an Intelligent Flight Battery immediately after flight as it may be too hot. Wait for the battery to cool down to the allowable charging temperature before charging again.
  2. To prevent damage, the battery only charges when the battery temperature is between 5° and 40° C (41° and 104° F). The ideal charging temperature is from 22° to 28° C (71.6° to 82.4° F). Charging at the ideal temperature range can prolong battery life. Charging stops automatically if the temperature of the battery cells exceed 55° C (131° F) during charging.
  3. Low-Temperature Notice:
    - Batteries cannot be used in extremely low-temperature environments of lower than -10° C (14° F).
    - Battery capacity is significantly reduced when flying at low temperatures from -10° to 5° C (14° to 41° F). Make sure to fully charge the battery before takeoff. Hover the aircraft in place for a while to warm up the battery after takeoff.
    - It is recommended to warm up the battery to at least 10° C (50° F) before takeoff when flying in low-temperature environments. The ideal temperature to warm up the battery is above 20° C (68° F).
    - The reduced battery capacity in low-temperature environments reduces the wind speed resistance performance of the aircraft. Fly with caution.
    - Take extra caution when flying at a high elevation with a low temperature.
  4. A fully charged battery will automatically discharge when it is idle for a period of time. Note that it is normal for the battery to emit heat during the discharging process.
  5. Fully charge the battery at least once every three months to maintain battery health. If the battery is not used for an extended period, battery performance may be affected or may even cause permanent battery damage. If a battery has not been charged or discharged for three months or more, the battery will no longer be covered by the warranty.
  6. For safety purposes, keep the batteries at a low power level in transit. Before transportation, it is recommended to discharge the batteries to 30% or lower.

## Installing/Removing the Battery

### Installation

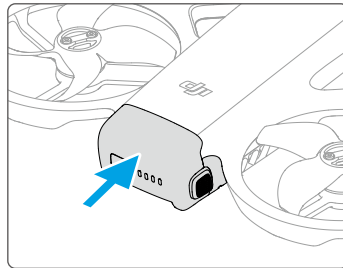

### Removal

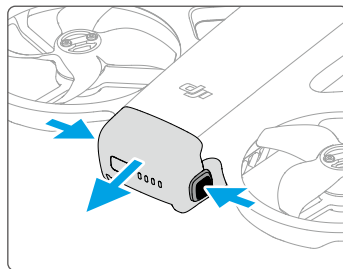

- 
- ⚠ • DO NOT insert or remove the battery while the aircraft is powered on.
  - Make sure the battery is mounted securely with a clicking sound. DO NOT launch the aircraft when the battery is not securely mounted, as this may cause poor contact between the battery and the aircraft and present hazards.
- 

## Using the Battery

### Checking the Battery Level

Press the power button once to check the current battery level.

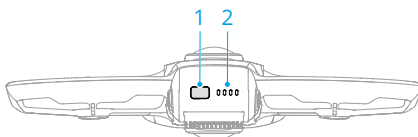

1. Power Button
2. Battery Level LEDs

The battery level LEDs display the power level of the battery during charging and discharging. The statuses of the LEDs are defined below:

- LED is on
- ◉ LED is flashing
- LED is off

Blinking Pattern	Battery Level
● ● ● ●	88-100%
● ● ● ◉	76-87%
● ● ● ○	63-75%
● ● ◉ ○	51-62%
● ● ○ ○	38-50%
● ◉ ○ ○	26-37%
● ○ ○ ○	13-25%
◉ ○ ○ ○	0-12%

### Powering On/Off

Press, then press and hold the power button to power the aircraft on or off. The battery level LEDs display the battery level when the aircraft is powered on. The battery level LEDs turn off when the aircraft is powered off.

## Charging the Battery



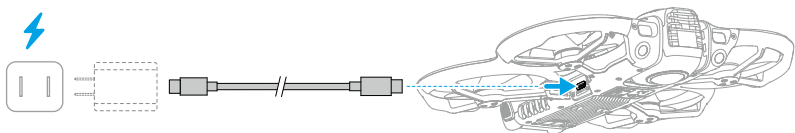

Fully charge the battery before each use. It is recommended to use the charging devices provided by DJI or other chargers that support the USB PD fast charging protocol.

### Using a Charger



⚠ • The battery cannot be charged if the aircraft is powered on.

The table below shows the battery level during charging.

Blinking Pattern	Battery Level
	0-50%
	51-75%
	76-99%
	100%

- The blinking frequency of the battery level LEDs differs depending on the USB charger used. If the charging speed is fast, the battery level LEDs will blink quickly.
- Four LEDs blinking simultaneously indicates the battery is damaged.

## Using the Charging Hub



It is recommended to click the link below or scan the QR code to watch the tutorial video.



<https://www.dji.com/avata-360/video>

- ⚠ • The environmental temperature affects the charging speed. Charging is faster in a well-ventilated environment at 25° C (77° F).
- The charging hub is only compatible with specific model of the Intelligent Flight Battery. DO NOT use the charging hub with other battery models.
- Place the charging hub on a flat and stable surface when in use. Make sure the device is properly insulated to prevent fire hazards.
- DO NOT touch the metal terminals on the battery ports.
- Clean the metal terminals with a clean, dry cloth if there is any noticeable buildup.

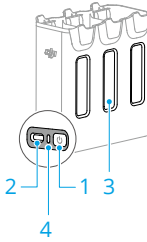

1. Function Button
2. USB-C Connector
3. Battery Port
4. Status LEDs

## How to Charge

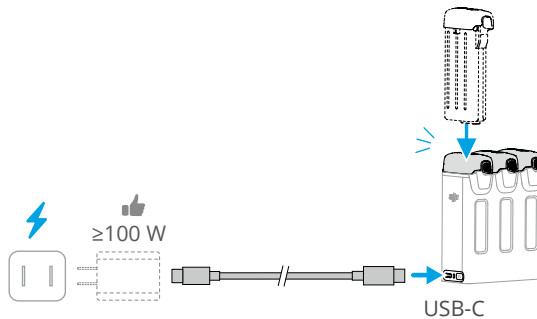

Insert the batteries into the battery ports of the charging hub until they click into place. Connect the charging hub to a power outlet using a USB charger.

The charging method varies depending on the power of the charger. Refer to the table below for details.

The battery can be stored in the charging hub after charging.

Charger Power < 65 W	Charges in sequence from highest to lowest battery level.
Charger Power $\geq$ 65 W	Charges three batteries simultaneously: First charges the two batteries with a lower battery level to the same level as the highest one and then charges the batteries simultaneously.

## Accumulating Power

1. Insert more than one battery into the charging hub, and press and hold the function button until the status LED turns green. The status LED of the charging hub pulses green, and the charge is transferred from the battery with the lowest power level to the battery with the highest power level.

2. To stop accumulating power, press and hold the function button until the status LED turns yellow. After stopping power accumulation, press the function button to check the power level of the batteries.





- 
-  • Power accumulation stops automatically in the following situations:
- The receiving battery is fully charged, or the power of the output battery is lower than 8%.
  - A charger or external device is connected to the charging hub during power accumulation.
  - Power accumulation is interrupted for more than 15 minutes due to abnormal battery temperature.
  - After accumulating power, charge the battery with the lowest power level as soon as possible to avoid discharge.
- 

## Status LED Descriptions

Blinking Pattern	Description
Solid yellow	The charging hub is idle
Pulses green	Charging the battery or accumulating power
Solid green	All batteries fully charged or supplying power to external devices
Blinks yellow	Temperature of the batteries is too low or too high (no further operation needed)
Solid red	Power supply error or battery error (remove and reinsert the batteries or unplug and plug in the charger)

## Battery Protection Mechanisms

The battery level LEDs can display battery protection notifications triggered by abnormal charging conditions.

LEDs	Blinking Pattern	Status
	LED2 blinks twice per second	Overcurrent detected
	LED2 blinks three times per second	Short circuit detected
	LED3 blinks twice per second	Overcharge detected
	LED3 blinks three times per second	Over-voltage charger detected
	LED4 blinks twice per second	Charging temperature is too low







LEDs	Blinking Pattern	Status
	LED4 blinks three times per second	Charging temperature is too high

If any of the battery protection mechanisms are activated, unplug the charger, and plug it in again to resume charging. If the charging temperature is abnormal, wait for it to return to normal. The battery will automatically resume charging without the need to unplug and plug in the charger again.

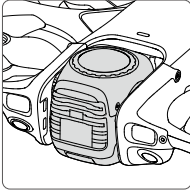
## 4.9 Gimbal and Camera

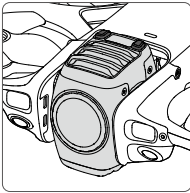
After the aircraft takes off, the gimbal status varies depending on the lens mode.

Lens Mode	Gimbal Status	Description
 360°		The gimbal remains stationary, and only the camera view can be adjusted.
 Single Lens		Gimbal tilt can be adjusted.

-  When the aircraft takes off for the first time, the gimbal will automatically rotate to switch the camera to 360° mode. For subsequent takeoffs, the gimbal will rotate to the lens mode used in the previous flight or set before takeoff.
- When the aircraft lands, the gimbal will automatically rotate back to the locked position with the footpads facing down.

## Gimbal Notice

-  Make sure there are no stickers or objects on the gimbal before taking off. Launch the aircraft from open and flat ground to protect the gimbal. It is

recommended to use with the included foldable landing pad. DO NOT tap or knock the gimbal after the aircraft is powered on.

- Remove the gimbal protector before powering on the aircraft. Attach the gimbal protector when the aircraft is not in use. When attaching the gimbal protector, make sure the gimbal is in the locked position.
  - Precision elements in the gimbal may be damaged by a collision or impact, which may cause the gimbal to function abnormally. Make sure to protect the gimbal from damage.
  - Avoid getting dust or sand on the gimbal, especially in the gimbal motors.
  - DO NOT add any extra payload other than an official accessory to the gimbal, as this may cause the gimbal to function abnormally or even lead to permanent motor damage.
  - Flying in heavy fog or clouds may make the gimbal wet, leading to temporary failure. The gimbal will recover full functionality once it is dry.
  - DO NOT use the aircraft in rainy or snowy weather. If encountering rain or snow during flight, land the aircraft immediately and clean the surface of the gimbal and gimbal motor promptly.
  - If there are strong winds, the gimbal may vibrate while recording.
  - When placing the aircraft, ensure the gimbal is locked and the footpads are facing down. If the gimbal is not locked, manually rotate it to the locked position, or power on the aircraft when it is flat and the gimbal is unobstructed. The gimbal will automatically return to the locked position.
  - After powering on, if the aircraft is not placed flat for an extended period or if it is significantly shaken, the gimbal may stop working and start resetting. In this case, place the aircraft flat and wait for it to recover.
  - In Single Lens mode, if the gimbal tilt angle is large, the gimbal may enter limit protection and automatically adjust its angle when the aircraft accelerates, decelerates, or brakes.
  - If an unexpected motor stop occurs mid-flight, the gimbal will automatically rotate back to the locked position.
- 

## Gimbal Angle

In Single Lens mode:

- Remote Controller: Use the gimbal dial on the remote controller or DJI Fly to control the tilt of the gimbal. In the camera view of DJI Fly, press and hold the screen until the gimbal adjustment bar appears. Drag the bar to control the gimbal's angle.

- **Motion Controller:** During flight, or when the accelerator is not being pressed and the aircraft is hovering, tilt the motion controller up and down to control the tilt of the gimbal.

---

 In 360° mode, the gimbal remains stationary, and the methods above are used only to adjust the camera view.

---

## Gimbal Modes

Two gimbal modes are available to meet different recording needs.

**Follow Mode:** The angle of the gimbal remains stable relative to the horizontal plane. This mode is suitable for capturing stable images.

**FPV Mode:** The gimbal rolls in sync with the rolling aircraft to provide a first-person flying experience.

---

 The gimbal mode can only be selected in 360° mode.

---

- **Remote Controller:** Go to the camera view in DJI Fly, tap \*\*\* > **Control**, and select the gimbal mode.
- **Goggles:** Go to **Settings > Control**, and select the gimbal mode.

## Camera Notice

- 
-  • DO NOT expose the camera lens to an environment with laser beams, such as a laser show, or point the camera at intense light sources for an extended period of time, such as the sun on a clear day, in order to avoid damaging the sensor.
- Make sure the temperature and humidity are suitable for the camera during use and storage.
  - Use a lens cleanser to clean the lens to avoid damage or poor image quality.
  - DO NOT block any ventilation holes on the camera, as the heat generated may damage the device or cause injury.
  - The aircraft uses SmartPhoto mode by default in Single Shot at 120MP resolution, which integrates features such as scene recognition or HDR for optimal results. SmartPhoto needs to take multiple shots continuously for image synthesis. When the aircraft or gimbal is moving, SmartPhoto will not be supported, and the image quality may differ.
  - The photos taken in Single Shot mode have no HDR effect in the following situations:

- When the aircraft or gimbal is moving, or if the aircraft is unable to hover stably due to high wind speeds.
  - The camera is in Auto mode and the EV setting is adjusted manually.
  - The camera is in Pro/Manual mode.
  - It is normal for parts of the aircraft to appear in the liveview. They will not appear in the final footage.
- 

## 4.10 Footage Storage and Export

### Storing

The aircraft supports the use of a microSD card to store your photos and videos. Refer to the Specifications for more information about recommended microSD cards.

Photos and videos can also be saved in the internal storage of the aircraft when no microSD card is available.

- 
-  A microSD card with a UHS-I Speed Grade 3 rating or higher is required to ensure recording performance. Refer to the specifications for more information about recommended microSD cards.
- 

### Exporting

- Use QuickTransfer to export the footage to a mobile device.
- Connect the aircraft to a computer using a data cable, export the footage in the internal storage of the aircraft or in the microSD card mounted on the aircraft. The aircraft does not need to be powered on during the exporting process.
- Remove the microSD card from the aircraft and insert it into a card reader, and export the footage in the microSD card through the card reader.

- 
-  • Ensure that the SD card slot and the microSD card are clean and free of foreign objects during use.
- DO NOT remove the microSD card from the aircraft when taking photos or videos. Otherwise, the microSD card may be damaged.
  - Check camera settings before use to ensure they are configured correctly.
  - Before capturing important photos or videos, take a few images to test whether the camera is operating correctly.

- Make sure to power off the aircraft correctly. Otherwise, the camera parameters will not be saved, and any recorded images or videos may be affected. DJI is not responsible for any loss caused by an image or video recorded in a way that is not machine-readable.

## Editing Panoramic Videos

Panoramic videos shot with the camera must be edited before you can share them as regular videos. Use DJI Fly on your phone for quick editing or professional software on your computer for advanced editing.

Watch the tutorial videos for details.



<https://www.dji.com/avata-360/video>

### 4.11 QuickTransfer

Follow the steps below to quickly download photos and videos from the aircraft to your mobile device.

1. Power on the aircraft and wait until the self-diagnostic tests of the aircraft are complete.
2. Turn on the Bluetooth and Wi-Fi on the mobile device, and make sure the positioning function is enabled as well.
3. Enter QuickTransfer mode using one of the methods below.
  - Launch DJI Fly on the mobile device and tap the QuickTransfer card on the home screen.
  - Launch DJI Fly on the mobile device, go to Album, and tap  in the upper right corner.
4. Once successfully connected, the files on the aircraft can be accessed and downloaded at high speed. Note that when connecting the mobile device to the aircraft for the first time, press and hold the power button of the aircraft to confirm.

## Allow QuickTransfer in Sleep

If the Allow QuickTransfer in Sleep feature is enabled, QuickTransfer can be used while the aircraft is powered off.

1. Allow QuickTransfer in Sleep is enabled by default.

---

 If the aircraft is connected with a remote controller, go to the camera view in DJI Fly, tap \*\*\* > **Camera** to enable or disable Allow QuickTransfer in Sleep.

---

2. When using Allow QuickTransfer in Sleep, you can only connect to an aircraft that displays the Sleep icon. The aircraft will enter sleep mode after powering off. The method of using QuickTransfer remains the same as in the powered-on state. If the mobile device and the aircraft are not connected via Wi-Fi or if the app is exited (with no ongoing download) for more than 1 minute, QuickTransfer will automatically exit and the aircraft will return to sleep mode.

Sleep mode automatically turns off under the following circumstances:

- The aircraft is inactive for 12 hours.
- The battery is replaced.
- A USB-C cable is connected to the aircraft.

To restore sleep mode, make sure there is no USB-C connection to the aircraft, and then press the power button once and wait for about 15 seconds.

When restoring sleep mode or using Allow QuickTransfer in Sleep for transmission, battery level LEDs 1&2 and LEDs 3&4 will blink alternately.



- 
-  • The maximum download rate can only be achieved in countries and regions where the 5.8 GHz frequency is permitted by laws and regulations, when using devices that support 5.8 GHz frequency band and Wi-Fi connection, and in an environment without interference or obstruction. If 5.8 GHz is not allowed by local regulations (such as in Japan), or your mobile device does not support the 5.8 GHz frequency band, or the environment has severe interference, then QuickTransfer will use the 2.4 GHz frequency band and its maximum download rate will reduce to 13 MB/s.
- When using QuickTransfer, it is not necessary to enter the Wi-Fi password on the settings page of the mobile device in order to connect. Launch DJI Fly and a prompt will appear to connect the aircraft.
  - Use QuickTransfer in an unobstructed environment with no interference and stay away from sources of interference such as wireless routers, Bluetooth speakers, or headphones.
-

# Remote Controller

---

## 5 Remote Controller

### 5.1 Remote Controller Operation

#### Powering On/Off

Press the power button once to check the current battery level.

Press, then press and hold to power the remote controller on or off.

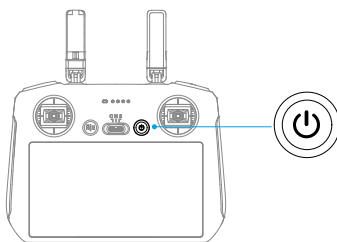

#### Charging the Battery

Connect the charger to the USB-C port on the remote controller.

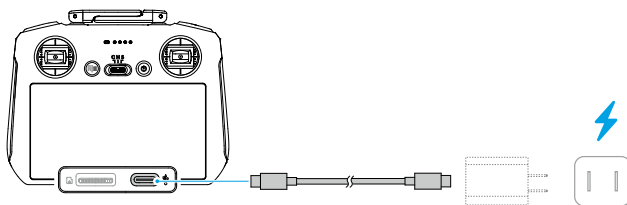

- ⚠ Fully charge the remote controller before each flight. The remote controller sounds an alert when the battery level is low.
- Fully charge the battery at least once every three months to maintain the battery's health.



## Controlling the Gimbal and Camera

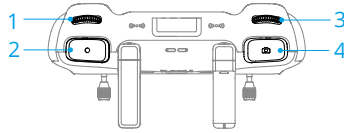

1. **Gimbal Dial:** Control the tilt of the gimbal/view.
2. **Record Button:** Press once to start or stop recording.
3. **Camera Control Dial:** Use to adjust the zoom by default. The dial function can be set to adjust the focal length, EV, shutter speed, and ISO.
4. **Shutter Button:** Press all the way down to take a photo.

## Flight Mode Switch

Toggle the switch to select the desired flight mode.

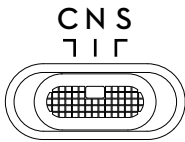

Position	Flight Mode
C	Cine Mode
N	Normal Mode
S	Sport Mode

## Flight Pause/RTH Button

Press once to make the aircraft brake and hover in place.

Press and hold the button until the remote controller beeps and starts RTH. The aircraft will return to the last recorded Home Point. Press the button again to cancel RTH and regain control of the aircraft.

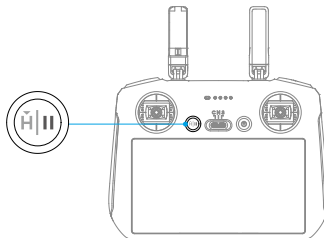



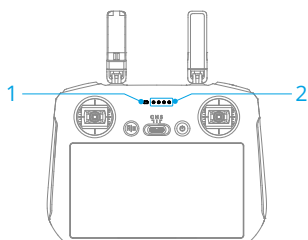





## 5.2 Remote Controller LEDs







1. Status LED
2. Battery Level LEDs

### Status LED

Blinking Pattern	Descriptions
 — Solid red	Disconnected from the aircraft.
 ..... Blinking red	The battery level of the aircraft is low.
 ..... Solid green	Connected with the aircraft.
 ..... Blinking blue	The remote controller is linking to an aircraft.
 — Solid yellow	Firmware update failed.
 — Solid blue	Firmware update successful.
 ..... Blinking yellow	The battery level of the remote controller is low.
 ..... Blinking cyan	Control sticks not centered.

### Battery Level LEDs

Blinking Pattern	Battery Level
	76-100%
	51-75%
	26-50%
	0-25%

## 5.3 Remote Controller Alert

The remote controller beeps to indicate an error or warning. Pay attention when prompts appear on the touchscreen or in DJI Fly.

Slide down from the top of the screen and select Mute to disable all alerts, or slide the volume bar to 0 to disable some alerts.

The remote controller sounds an alert during RTH, which cannot be cancelled. The remote controller sounds an alert when the battery level of the remote controller is low. A low battery level alert can be cancelled by pressing the power button. When the battery level is critically low, the alert cannot be cancelled.

There will be an alert if the remote controller is not used for a period of time while it is powered on but is not connected to the aircraft. It will automatically power off after the alert stops. Move the control sticks or press any button to cancel the alert.

## 5.4 Optimal Transmission Zone

The signal between the aircraft and the remote controller is most reliable when the antennas are positioned in relation to the aircraft as illustrated below. If the signal is weak, adjust the remote controller orientation, or fly the aircraft closer to the remote controller.

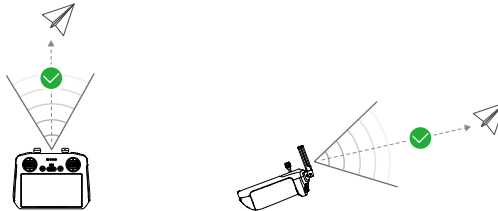

- ⚠ • DO NOT use other wireless devices operating at the same frequency as the remote controller. Otherwise, the remote controller will experience interference.
- A prompt will be displayed in DJI Fly if the transmission signal is weak during flight. Adjust the remote controller orientation according to the attitude indicator display to make sure that the aircraft is in the optimal transmission range.

## 5.5 Linking the Remote Controller

The remote controller is already linked to the aircraft when purchased together as a combo. Otherwise, follow the steps below to link the remote controller and the aircraft after activation.

1. Power on the aircraft and the remote controller.
2. Launch DJI Fly.
3. In camera view, tap \*\*\* > **Control** > **Connect to Aircraft**. During linking, the status LED of the remote controller blinks blue and the remote controller beeps.
4. Press and hold the power button of the aircraft for more than four seconds. The aircraft beeps, and its battery level LEDs blink in sequence to indicate it is ready to link. The remote controller will beep twice, and its status LED will turn solid green to indicate linking is successful.

- 
-  Make sure the remote controller is within 0.5 m of the aircraft during linking.
  - The remote controller will automatically unlink from an aircraft if a new remote controller is linked to the same aircraft.
- 

## 5.6 Operating the Touchscreen

- 
-  Note that the touchscreen is not waterproof. Operate with caution.
- 

### Screen Gestures

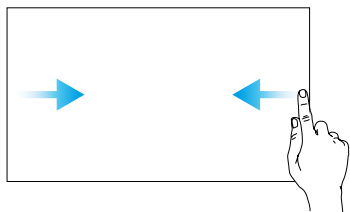

**Back:** Slide from the left or right to the center of the screen to return to the previous screen.

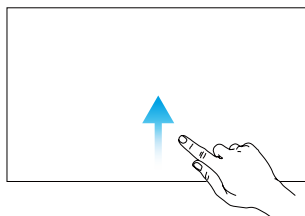

**Return to DJI Fly:** Slide up from the bottom of the screen to return to DJI Fly.

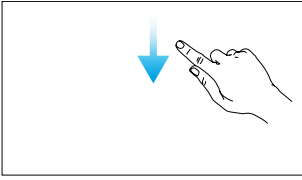

**Open the status bar:** Slide down from the top of the screen to open the status bar when in DJI Fly.

The status bar displays the time, Wi-Fi signal, battery level of the remote controller, etc.

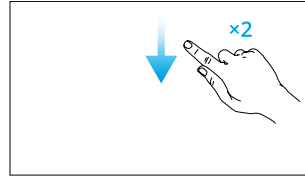

**Open Quick Settings:** Slide down twice from the top of the screen to open Quick Settings when in DJI Fly.

# Goggles and Motion Controller

---

## 6 Goggles and Motion Controller

### 6.1 Goggles Operation

#### Goggles Buttons

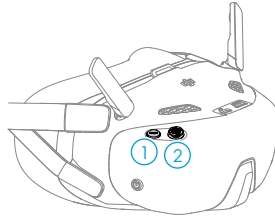

##### 1. Back Button

Press to return to the previous menu or exit the current view.

##### 2. 5D Button

Press or push to open different menus from the FPV view of the goggles. After the menu is opened, push to navigate through the menu or adjust the parameter value. Press to confirm the selection.

During video playback, press the button to control it.

#### Opening the Menu

##### Shortcut Menu

Push the 5D button backward from the FPV view to open the shortcut menu.

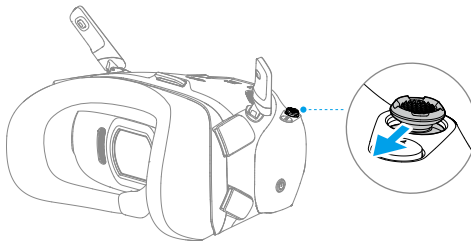



## Camera Settings

Push the 5D button forward from the FPV view to open the camera settings panel. In the parameter panel, push to the right to view and set more parameters.

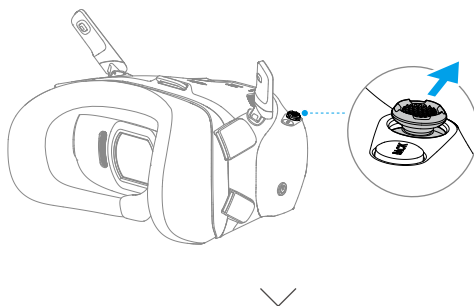



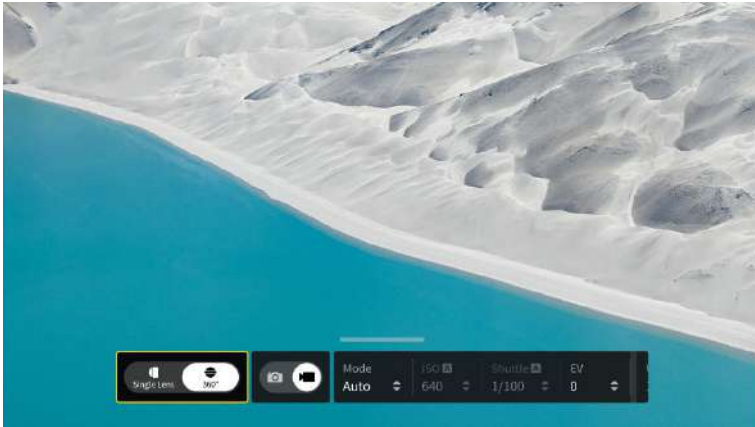

## Goggles Menu

Press down the 5D button or push it to the right from the FPV view to open the menu.

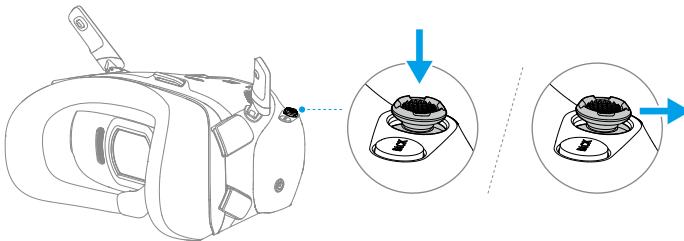

- Enter **Settings > Safety**, Camera View Before Loss helps to find the location of the aircraft by using the captured video of the aircraft within a period before the signal is lost. If the aircraft still has signal and battery power, turn on ESC beeping to locate the aircraft using a beeping sound that is emitted from the aircraft.
- Enter **Settings > Control** to view the goggles tutorial.

## AR Cursor

- AR Cursor cannot function properly when being used on moving objects, such as cars and ships.

Before takeoff or when using the lock button to trigger the aircraft to hover, users can use the AR Cursor (the white line with a circle at the end) to interact with the screen of the goggles.



### Recenter the Cursor

If the cursor is not displayed on the screen of the goggles, hold the motion controller as shown below, and then press and hold the dial on the left side of the motion controller to recenter the cursor.

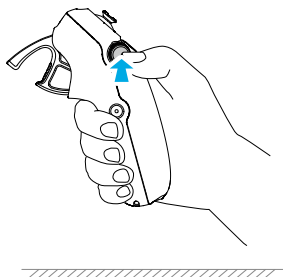

If the cursor still cannot be found, tilt the motion controller up or down until the cursor appears on the screen.

### Operating the Menu

- Using motion controller movements, move the cursor to the arrow at the left side of the screen. Gently press the accelerator to the first stop position, then the cursor will become small and the menu will be opened.



Use the joystick on the motion controller to scroll up or down in the menu.

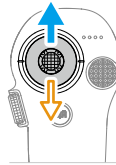

To exit or return to the previous menu, push the accelerator forward, or gently press the accelerator when the cursor is on any empty spot on the screen.

- Move the cursor to the arrow at the top of the screen, press the accelerator to enter the shortcut menu, and configure settings such as recording.

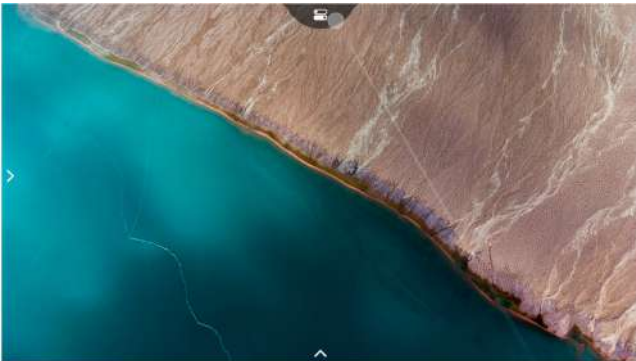

- Move the cursor to the arrow on the bottom of the screen, press the accelerator to enter camera settings, and configure settings for the parameters of the aircraft camera.



Use the joystick on the motion controller to scroll left or right in the menu.

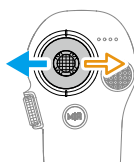

## Goggles Footage Storage and Export

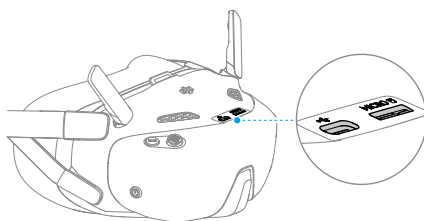

### Footage Storage

The goggles support the installation of a microSD card. After a microSD card is inserted, if Record With is set to both the aircraft and the goggles, while the aircraft is recording video, the goggles will simultaneously record the liveview displayed on the screen and store it on the microSD card of the goggles.

## Footage Export

The recorded footage can be exported via the following methods.

- Power on the goggles. Connect the USB-C port of the goggles to a PC, and follow the on-screen prompts to export the footage.
- Remove the microSD card from the goggles and insert it into a card reader, and export the footage in the microSD card through the card reader.

The screen recording includes the OSD elements by default. To record the screen without the OSD elements, change the settings as shown below:

1. Open the goggles menu.
2. Select **Settings > Camera > Advanced Camera Settings**, and disable **Camera View Recording**.

## Liveview Sharing

DJI Goggles N3 can share a flight liveview via the following methods.



- Power on the aircraft, goggles, and remote control device. Make sure all the devices are linked.



- Operate Liveview Sharing prior to taking off, or when the aircraft is braking or hovering, to avoid interfering with the pilot's operation.
  - The goggles only support connecting to one smartphone for sharing the liveview at a time. Other smartphones cannot be connected during this period.
  - When connected to a smartphone, liveview sharing will be paused when viewing the images or videos in the album. Exit the album to recover sharing.
  - When using the broadcasting mode, the audience and the pilot goggles must select the same aircraft model.
- 

## Wired Connection with Smartphone

1. Connect the USB-C port of the goggles to the smartphone.
2. Launch DJI Fly app and tap **GO FLY** in the lower right corner of the screen to enter the liveview.

## Broadcasting to Other Goggles

1. Enter the DJI Goggles N3 menu, select **Transmission** and enter the **Pilot** sub-menu.

2. Turn on Broadcasting mode, and the device number will be displayed.
3. On the other goggles, enter the goggles menu, select **Transmission** and enter the **Audience** sub-menu.
4. If any nearby goggles turns on the Broadcasting mode, the device and its signal strength can be viewed in the **Audience** sub-menu. Select the device number to access the liveview. Switching to **Pilot** sub-menu to exit the shared liveview.

## 6.2 Motion Controller Operation

### Button Features

---

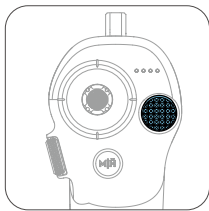

#### Lock Button

- Takeoff: Press twice to start the aircraft motors, then press and hold to make the aircraft take off. The aircraft will ascend to approximately 1.2 m and hover.
- Landing: While the aircraft is hovering, press and hold to land the aircraft and stop the motors.
- Brake: Press during flight to make the aircraft brake and hover in place.

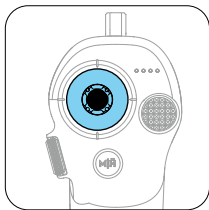

#### Joystick

- Move up or down to make the aircraft ascend or descend.
- Move left or right to make the aircraft move left or right horizontally.
- Move the joystick to perform different Easy ACRO actions when Easy ACRO is enabled.

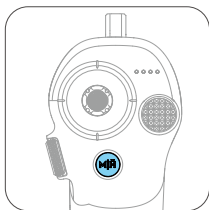

#### Mode Button

- Press to switch between Normal and Sport mode.
- Press and hold to initiate RTH. When the aircraft is performing RTH, press the mode button or lock button once to cancel RTH.
- When the battery level is low and only sufficient to fly to the Home Point, a warning prompt will appear in the goggles and RTH will be triggered following the prompt. Press the mode button once to cancel the prompt.



### Dial

- Rotate to tilt the view during RTH and landing (above 2 m).
- Rotate the dial to switch between Easy ACRO actions when Easy ACRO is enabled.
- Press and hold the dial to recenter the cursor on the screen when using AR Cursor.

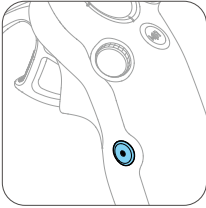

### Shutter/Record Button

- Press once: Take a photo or start or stop recording.
- Press and hold: Switch between photo and video mode.

## Motion Controller Alert

The remote controller sounds an alert when the battery level is between 6% and 10%. A low battery level alert can be canceled by pressing the power button. A critical battery level alert will sound when the battery level is less than 5% and cannot be canceled. The remote controller sounds an alert during RTH, which cannot be canceled.

## Optimal Transmission Zone

The signal is most reliable when the relative distance between the motion controller and the goggles is less than 3 m.



- It is recommended to use the device in an open, outdoor environment to avoid having obstacles between the motion controller and the goggles. Otherwise, the transmission may be affected.

- In order to avoid interference, DO NOT use other wireless devices on the same frequency as the motion controller.

## 6.3 Linking

Preparation before linking:

1. Power on the aircraft, the goggles, and the remote control device before linking. Make sure the devices are within 0.5 m of each other during linking. Make sure the devices are updated to the latest firmware version and have enough battery level.
2. Open the goggles menu, select **Status** and make sure that the aircraft model displayed at the top of the menu is correct. Otherwise, select **Switch** from the upper right corner of the menu and then select the correct aircraft.

### Linking via DJI Fly App (recommended)

Keep the goggles connected to the smartphone after activation. Tap **Connection Guide** on DJI Fly from the smartphone and follow the on-screen instructions for linking.

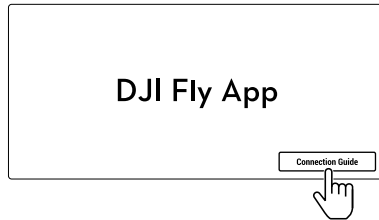

### Linking via Button

1. Linking the aircraft and the goggles:

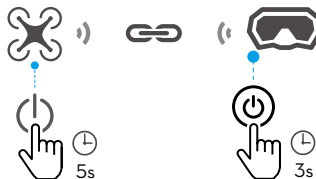

- a. Press and hold the power button on the aircraft until it beeps once and the battery level LEDs start to blink in sequence.



- b. Press and hold the power button on the goggles until the goggles start to beep continuously and the power button starts to blink yellow.
  - c. Once linking is completed, the battery level LEDs of the aircraft turn solid and display the battery level, the goggles stop beeping, and image transmission can be displayed normally.
2. Linking the goggles and remote control device:



- a. Press and hold the power button on the goggles until the goggles start to beep continuously and the power button starts to blink yellow.
- b. Press and hold the power button on the remote control device until it starts to beep continuously and the battery level LEDs start to blink in sequence.
- c. Once linking is completed, the goggles and remote control device stop beeping and display the battery level.

- 
- ⚠** • The aircraft can be controlled with only one remote control device during flight. If the aircraft has been linked with multiple remote control devices, turn off the other remote control devices before linking.
- 

## 6.4 Cleaning and Maintenance

Clean the surface of the goggles with a soft, dry, clean cloth. Use the lens cleaning cloth to clean the lenses in a circular motion from the center to the outer edges.

- 
- ⚠** • DO NOT clean the integrated goggle lenses with alcohol wipes.
- Clean the lenses gently. DO NOT scratch them as this will affect viewing quality.
  - DO NOT use alcohol or other cleanser to wipe the foam padding and the soft side of the battery compartment.
  - DO NOT tear or scratch the foam padding, and the soft side of the battery compartment, or other components with sharp objects.

- Store the goggles in a dry place at room temperature to avoid damage to the lenses and other optical components from high temperatures and humid environments.
  - Keep the lenses away from direct sunlight to avoid screen damage.
-

# Appendix

---

## 7 Appendix

### 7.1 Specifications

Visit the following website for specifications.

<https://www.dji.com/avata-360/specs>

### 7.2 Compatibility

Visit the following website to get the information on compatible products.

<https://www.dji.com/avata-360/faq>

### 7.3 Firmware Update

#### Using DJI Fly

When using the remote controller, connect the aircraft and remote controller, and run DJI Fly. You will be notified if a new firmware update is available. Follow the on-screen instructions to start the update. Note that you cannot update the firmware if the remote controller is not linked to the aircraft. An internet connection is required during the firmware update.

When using Immersive Motion Control, power on the aircraft, goggles, and remote control device, and make sure all the devices are linked. Connect the USB-C port of the goggles to the smartphone. Run DJI Fly, and follow the prompt to update. An internet connection is required during the firmware update.

#### Using DJI Assistant 2 (Consumer Drones Series)

1. Power on the device. Connect the device to a computer with a USB-C cable.
2. Launch DJI Assistant 2 (Consumer Drones Series) and log in with your DJI account.
3. Select the device and click **Firmware Update** on the left side of the screen.
4. Select the firmware version.
5. Wait for the firmware to download. The firmware update will start automatically. Wait for the firmware update to complete.

- 
-  • The battery firmware is included in the aircraft firmware. Be sure to update all batteries.
- Make sure to follow all the steps to update the firmware, otherwise the update may fail.

- Make sure the computer is connected to the internet during the update.
- DO NOT unplug the USB-C cable during an update.
- The firmware update will take approximately 10 minutes. During the update process, it is normal for the gimbal to go limp, the aircraft status indicators to blink, and the aircraft to reboot. Wait patiently for the update to complete.

Visit the following link and refer to the *Release Notes* for firmware update information:

<https://www.dji.com/avata-360/downloads>

## 7.4 Flight Recorder

Flight data including flight telemetry, aircraft status information, and other parameters are automatically saved to the internal data recorder of the aircraft. The data can be accessed using DJI Assistant 2 (Consumer Drones Series).

## 7.5 Post-Flight Checklist

- Make sure to perform a visual inspection so that the aircraft, remote controller, gimbal camera, Intelligent Flight Batteries, and propellers are in good condition. Contact DJI support if any damage is noticed.
- Make sure that the camera lens and vision system sensors are clean.
- Make sure to store aircraft correctly before transporting it.

## 7.6 Maintenance Instructions

To avoid serious injury to children and animals, observe the following rules:

1. Small parts, such as cables and straps, are dangerous if swallowed. Keep all parts out of reach of children and animals.
2. Store the Intelligent Flight Battery and remote controller in a cool, dry place away from direct sunlight to ensure the built-in LiPo battery does NOT overheat. Recommended storage temperature: between 22° and 28° C (71° and 82° F) for storage periods of more than three months. Never store in environments outside the temperature range of -10° to 45° C (14° to 113° F).
3. DO NOT allow the camera to come into contact with or become immersed in water or other liquids. If it gets wet, wipe dry with a soft, absorbent cloth. Turning on an aircraft that has fallen in water may cause permanent component damage. DO NOT

use substances containing alcohol, benzene, thinners, or other flammable substances to clean or maintain the camera. DO NOT store the camera in humid or dusty areas.

4. Check every aircraft part after any crash or serious impact. If there are any problems or questions, contact a DJI authorized dealer.
5. Regularly check the Battery Level Indicators to see the current battery level and overall battery life. The battery is rated for 200 cycles. It is not recommended to continue use afterward.
6. Make sure to transport the aircraft with the arms folded when powered off.
7. Make sure to transport the remote controller with antennas folded when powered off.
8. The battery will enter sleep mode during long-term storage. Charge the battery to exit from sleep mode.
9. Store the aircraft, remote controller, battery, and charger in a dry environment.
10. Remove the battery before servicing the aircraft (e.g., cleaning or attaching and detaching the propellers). Make sure that the aircraft and the propellers are clean by removing any dirt or dust with a soft cloth. Do not clean the aircraft with a wet cloth or use a cleanser that contains alcohol. Liquids can penetrate the aircraft housing, which can cause a short circuit and destroy the electronics.

## 7.7 Troubleshooting Procedures

### 1. How to solve the gimbal drift issue during flight?

Calibrate IMU and compass in DJI Fly. If the problem persists, contact DJI Support.

### 2. No function

Check if the Intelligent Flight battery and the remote controller are activated by charging. If the problems persist, contact DJI Support.

### 3. Power-on and start-up problems

Check if the battery has power. If yes, contact DJI Support if it cannot be started normally.

### 4. Firmware update issues

Follow the instructions in the user manual to update the firmware. If the firmware update fails, restart all the devices and try again. If the problem persists, contact DJI Support.

### 5. Procedures to reset to factory default

Use the DJI Fly app to reset to factory default settings.

### 6. Shutdown and power-off problems

Contact DJI Support.

## 7. How to detect careless handling or storage in unsafe conditions

Contact DJI Support.

## 7.8 Risks and Warnings

When the aircraft detects a risk after powering on, there will be a warning prompt on DJI Fly. Pay attention to the list of situations below.

- If the location is not suitable for takeoff.
- If an obstacle is detected during flight.
- If the location is not suitable for landing.
- If the compass and IMU experience interference and need to be calibrated.
- Follow the on-screen instructions when prompted.

## 7.9 Disposal



Observe the local regulations related to electronic devices when disposing of the aircraft and remote controller.

### Battery Disposal

Dispose of the batteries in specific recycling containers only after a complete discharge. DO NOT dispose of the batteries in regular trash containers. Strictly follow the local regulations regarding the disposal and recycling of batteries.

Dispose of a battery immediately if it cannot be powered on after over-discharging.

If the power button is disabled and the battery cannot be fully discharged, contact a professional battery disposal/recycling agency for further assistance.

## 7.10 C1 Certification

DJI Avata 360 is compliant with C1 certification requirements. There are some requirements and restrictions when using DJI Avata 360 in EU member states, EFTA member states (EFTA, i.e. Norway, Iceland, Liechtenstein, Switzerland) and Georgia.

Model	DVN3NT/DVN3XT
-------	---------------

UAS Class	C1
Maximum Take-Off Mass (MTOM)	455 g
Sound Power Level	81 dB
Maximum Propeller Speed	27150 RPM

### MTOM Statement

The MTOM of DJI Avata 360 (Model DVN3NT/DVN3XT) is 455 g to comply with C1 requirements.

You must follow the instructions below to comply with the MTOM requirements.

- DO NOT add any payload to the aircraft except the items listed in the List of Items including qualified accessories section.
- DO NOT use any non-qualified replacement parts, such as intelligent flight batteries or propellers, etc.
- DO NOT retrofit the aircraft.

### List of Items, including qualified accessories

Item	Model Number	Dimensions	Weight
Propellers	3340S	83.4× 101.6 mm (diameter×thread pitch)	3.5 g (each piece)
Intelligent Flight Battery	BWXVN1-2700-14.3 2	119.2×49×23 mm	Approx. 149.5 g
microSD Card*	N/A	15×11×1.0 mm	Approx. 0.3 g

\* Not included in the original packaging.

### List of Spare and Replacement Parts

- DJI Avata 360 Propellers
- DJI Avata 360 Intelligent Flight Battery

### Direct Remote ID

- Transport Method: Wi-Fi Beacon.
- Method of uploading the UAS Operator Registration Number to the aircraft: Enter DJI Fly, tap \*\*\* > **Safety** > **UAS Remote Identification**, and then upload UAS operator registration number.



## Remote Controller and Goggles Warnings

The remote controller indicator will glow red after disconnecting with the aircraft. DJI Fly and goggles will issue a warning prompt after disconnecting from the aircraft. The remote controller and goggles will beep and power off automatically after disconnecting from aircraft and with no operation for a long time.

- 
- ⚠ • Avoid interference between the remote control devices and other wireless equipment. Make sure to turn off the Wi-Fi on nearby mobile devices. Land the aircraft as soon as possible if there is interference.
  - If an unexpected operation occurs, release the control sticks or press the flight pause button on the remote controller, or press the lock pause button on the motion controller.
- 

## GEO Awareness

GEO Awareness contains the features listed below.

UGZ (Unmanned Geographical Zone) Data update: You can update the FlySafe data by using the data update feature automatically or storing the data in the aircraft manually.

- Method 1: Go to Settings in DJI Fly and tap **About > FlySafe Data > Check for Updates** to update the FlySafe data automatically.
- Method 2: Check the website of your national aviation authority regularly and obtain latest UGZ data to import to your aircraft. Go to Settings in DJI Fly, tap **About > FlySafe Data > Import from Files**, and then follow the on-screen instructions to store and import the UGZ data manually.

- 
- 🔔 • A prompt will appear in the DJI Fly app when the import completes successfully. If the import fails due to improper data format, follow the on-screen prompt and retry.
- 

GEO Awareness Map Drawing: After the latest UGZ data is updated, a flight map with a restricted zone will be displayed in the DJI Fly app. Name, effective time, height limit, etc., can be viewed by tapping the area.

### AGL (Above Ground Level) Statement

The vertical part of Geo-Awareness may use the AMSL altitude or the AGL height. The choice between these two references is specified individually for each UGZ. Neither AMSL altitude nor the AGL height is supported by DJI Avata 360. The height H appears in the DJI Fly app camera view, which is the height from the aircraft takeoff point to the aircraft. The height above the takeoff point may be used as an approximation but may differ

more or less from the given altitude/height for a specific UGZ. The remote pilot remains responsible for not breaching the vertical limits of the UGZ.

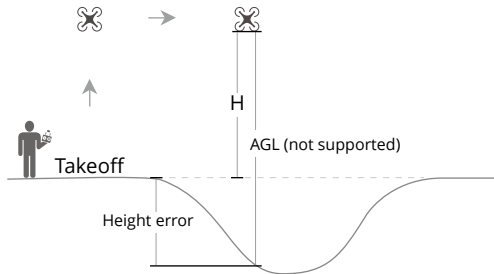

## GEO Zones

### Restricted Zones

Appear red in the DJI app. You will be prompted with a warning, and flight is prevented. UA cannot fly or take off in these zones. Restricted Zones may be unlocked, to unlock contact [flysafe@dji.com](mailto:flysafe@dji.com) or go to [Unlock A Zone at dji.com/flysafe](https://www.dji.com/unlock-a-zone).

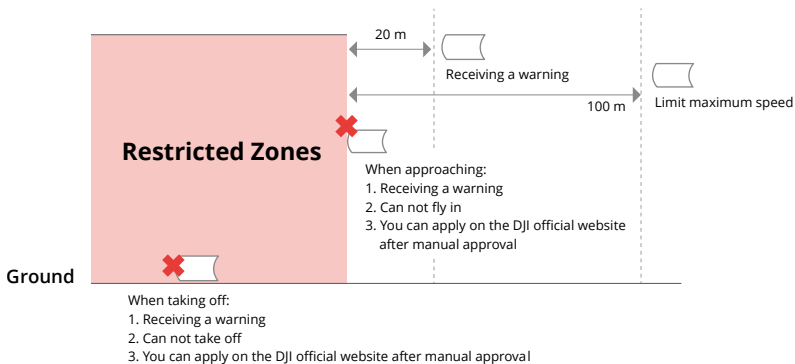

### Authorization Zones

Appear blue in the DJI app. You will be prompted with a warning, and flight is limited by default. UA cannot fly or take off in these zones unless authorized. Authorization Zones may be unlocked by authorized users using a DJI verified account.

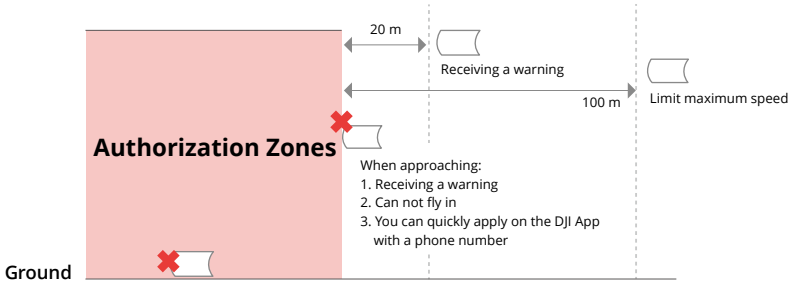

### Altitude Zones

Altitude zones are zones with a limited altitude and appear in gray on the map. When approaching, you will receive a warning in the DJI app.

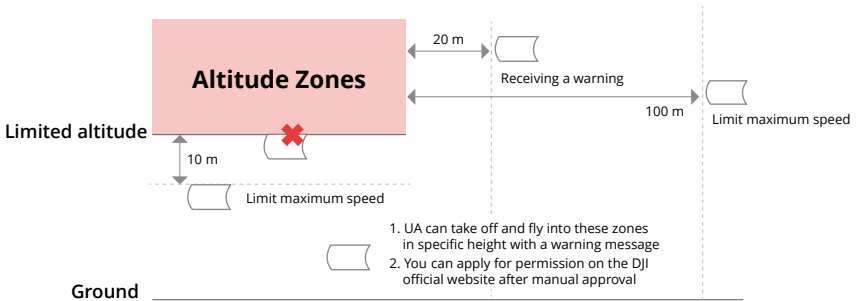

### Enhanced Warning Zones

A warning message will appear when the drone reaches the edge of the zone.

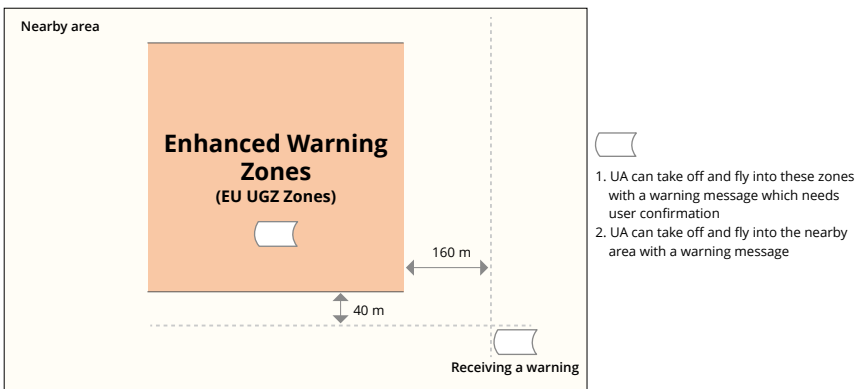

## Warning Zones

A warning message will prompt you when the drone reaches the edge of the zone.

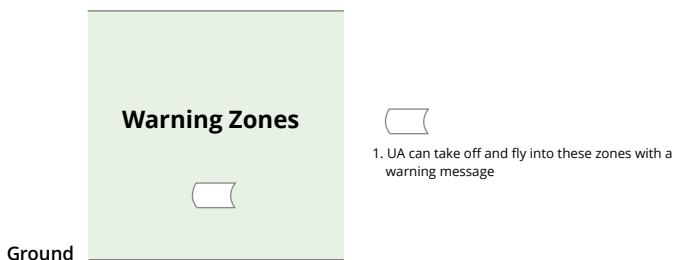

- 
-  • When the aircraft and DJI Fly app cannot obtain a GPS signal, the GEO awareness function will be inoperative. Interference of the aircraft antenna or disabling the GPS authorization in DJI Fly will cause the GPS signal fails to be obtained.
- 

## EASA Notice

Make sure to read the Drone Information Notices document included in the package before use.

Visit the link below for more EASA notice information on traceability.

<https://www.easa.europa.eu/en/document-library/general-publications/drones-information-notices>

## Original Instructions

This manual is provided by SZ DJI Technology, Inc., and the content is subject to change.

Address: Lobby of T2, DJI Sky City, No. 53 Xianyuan Road, Xili Community, Xili Street, Nanshan District, Shenzhen, China, 518055.

## 7.11 FAR Remote ID Compliance Information

The unmanned aircraft system is equipped with a Remote ID system that meets the requirements of 14 CFR Part 89.

- The aircraft automatically broadcasts Remote ID messages from takeoff to shutdown. An external device such as a cell phone or tablet is required to be connected as a

location source to DJI mobile devices without an integrated GNSS system,<sup>[1]</sup> and must run the DJI flight control app such as DJI Fly in the foreground and always allow the DJI flight control app to obtain its accurate location information. The connected external device must minimally be one of the following:

- FCC Certified personal wireless device that uses GPS with SBAS (WAAS) for location services; or
- FCC Certified personal wireless device with integrated GNSS.

Also, the external device must be operated in a way that does not interfere with the location reported and its correlation to the operator location.

- The aircraft automatically initiates a pre-flight self-test (PFST) of the Remote ID system before takeoff and cannot take off if it does not pass the PFST.<sup>[2]</sup> The results of the PFST of the Remote ID system can be viewed in either a DJI flight control app such as DJI Fly or DJI goggles.
- The aircraft monitors the Remote ID system functionality from pre-flight to shut down. If the Remote ID system malfunctions or has a failure, an alarm will be displayed in either a DJI flight control app such as DJI Fly or DJI goggles.
- The aircraft using the Intelligent Flight Battery does not activate Remote ID system.
- You can visit the official website of FAA to learn more about aircraft registration and Remote ID requirements.

#### Footnotes

[1] DJI mobile devices without an integrated GNSS system such as DJI RC-N3, and DJI Goggles 2.

[2] The pass criterion for PFST is that the hardware and software of the Remote ID required-data source and radio transmitter in the Remote ID system are functioning properly.

## 7.12 Aftersales Information

Visit <https://www.dji.com/support> to learn more about aftersales service policies, repair services, and support.



Contact  
DJI SUPPORT

This content is subject to change without notice.  
Download the latest version from



<https://www.dji.com/avata-360/downloads>

If you have any questions about this document, please contact DJI by sending a message to [DocSupport@dji.com](mailto:DocSupport@dji.com).

DJI and AVATA are trademarks of DJI.  
Copyright © 2026 DJI All Rights Reserved.