

EX4 Operation Manual

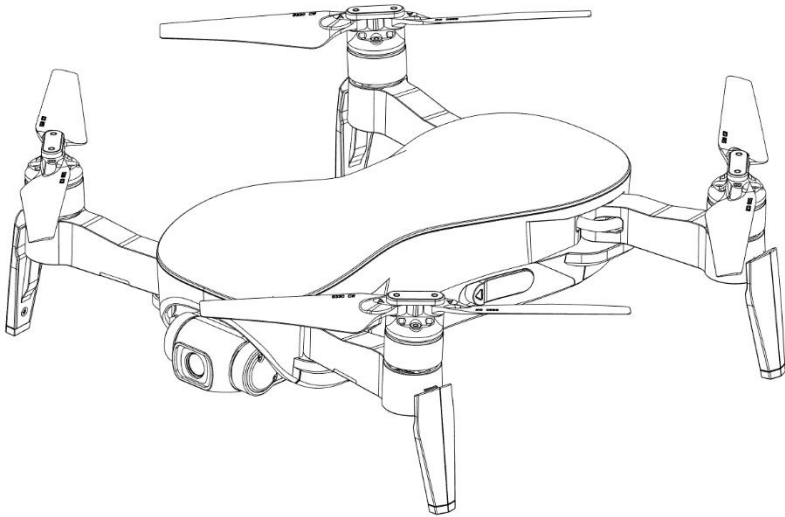

Important Notes:

- For safety and to avoid loss of property, please read this manual carefully.
- Please do not disassemble, modify or repair the aircraft. If necessary, please contact the agent.
- Please download this manual in PDF on "Help" in the upper right corner of the APP home page.
- This manual is subject to change without prior notice.



Contents

Contents.....	1
Product Overview.....	1
Introduction.....	1
Preparing the Aircraft.....	1
Aircraft Diagram.....	2
Flight Modes.....	3
Aircraft LEDs and Status Indicator.....	4
Remote Controller Status Indicator.....	5
Return to Home (RTH).....	5
Vision Position System.....	6
Aircraft Power Switch.....	8
Aircraft Battery.....	8
Attach and Detach the Propellers.....	10
Remote Controller.....	11
Power On and Power Off.....	11
Function and Status of Remote Controller.....	11
Throttle Control Stick Mode.....	14
Mounting the Phone Holder.....	14
Download APP.....	15
Flight.....	16
Flight Environment Requirements.....	16
Test Flight.....	16
Remote Controller to Control Flight.....	21
Use APP to Control the Aircraft.....	24
Introduction of Main Interface.....	28
Flight Modes for APP.....	31
Photo and Video for APP.....	34
Appendix.....	37
Specification.....	37
Warranty Information.....	40
Important Statement.....	40
Flight Safety Guidelines.....	41

Product Overview

Introduction

The EX4 aircraft is equipped with a vision positioning and GPS positioning system, which allows it to fly and hover stably indoors and outdoors, and has functions such as one key RTH, orbit mode, Track, and waypoint flight, etc. The EX4 is equipped with a 3-axis mechanical stabilization gimbal to capture high-resolution pictures and videos. It can adjust the camera angle during flight to capture unique photos and videos from different angles for better aerial photography experience.

The DF806 can be used with remote controller and APP to realize various operations and settings of the aircraft and camera. The App on the phone can display real time high-definition FPV (First-person view) and information like flight parameters at the same time.

Its maximum flight speed is 30km/h, flight time approach to 25 minutes.

Preparing the Aircraft.

Unfold the Aircraft

The Aircraft is folded inside the package. Follow the steps below to unfold the aircraft.

1. Step 1: Expand the arm outward (Pic. 1);
2. Step 2: Unfold the landing gear (Pic. 2);
3. Step 3: Separate the propeller blades (Pic. 3);
4. Step 4: Unfold the other arms and repeat step 2~3 with each arm (Pic. 4).

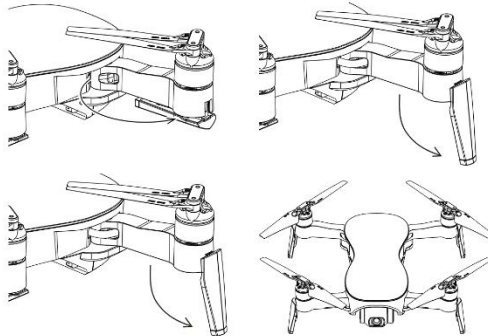

Pic. 1

Pic. 2

Pic. 3

Pic. 4

Battery Installation

1. Step 1: Slide the battery into the front of the battery compartment (Pic. 5);
2. Step 2: Then press the back of the battery down (Pic. 6);
3. Step 3: make sure that the latch on the battery is locked and the battery is in place. (Pic.7).

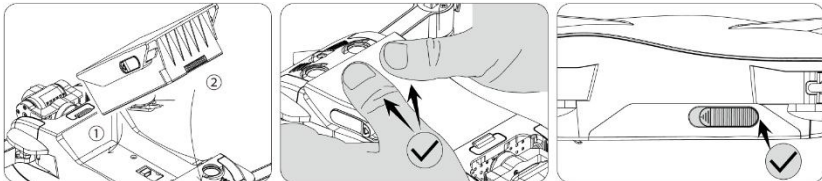

Pic. 5

Pic. 6

Pic. 7

Warning: If the battery is not installed properly, the aircraft may crash due to power-cut during flight.

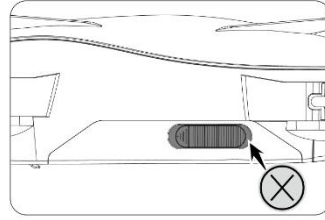
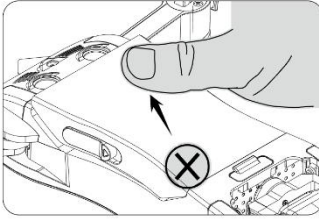

Pic. 8

Pic. 9

- Please use both hands to install the battery. Installing the battery with one hand may result in poor battery installation.

TF Card Installation

The TF card slot is in the front of the bottom of the aircraft body.

Before installing the TF card, open the TF card slot cover as shown on the right picture, then insert the TF card into the slot, and confirm that the TF card is in the right place, then close the TF card slot cover.

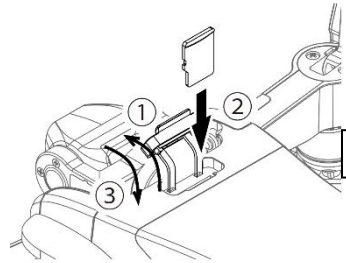

Pic. 10

- Please use micro SD card with transmission speed of Class 10 and above or UHS-1 rating; maximum support for 32GB capacity.
- Warning: Do not install or remove the TF card while the aircraft is powered on. Otherwise, errors will occur for the data stored.

Aircraft Diagram

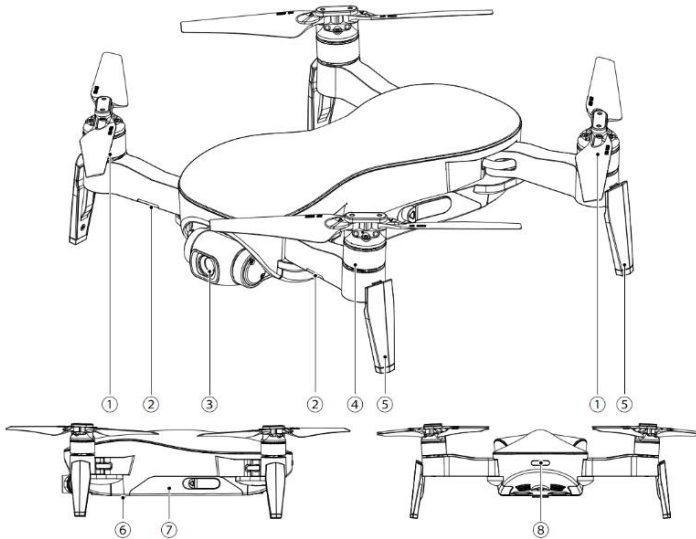

Pic. 11

α Counterclockwise Motor/ B	β Optical Flow Status Indicator	χ Gimbal/Camera
δ Clockwise Motor/A Propeller	ε Landing Gear	ϕ TF Card Slot

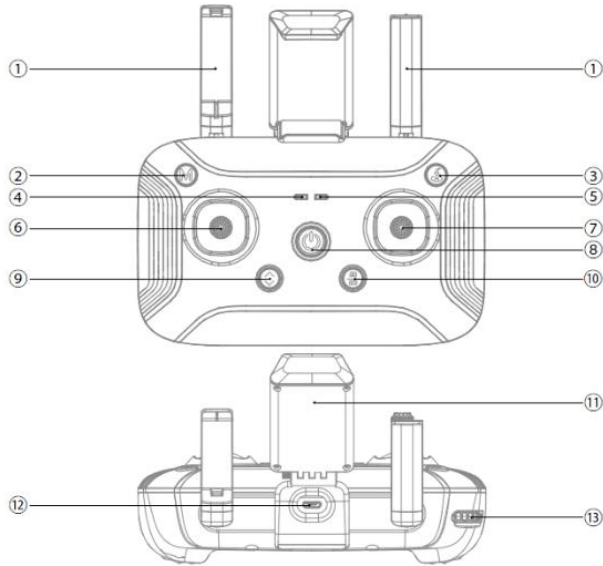
γ Aircraft Battery η Flight Status Indicator

Pic. 12

 α Antenna ε Power Indicator ι One key μ Camera Pitch β Flight Mode Switch ϕ Left Joystick φ Photo/Video χ Return to Home γ Right Joystick κ Mobile Phone δ Mode Indicator η Power Switch λ USB Charging

Flight Modes

The EX4 has the following flight modes:

Position Mode:

When the aircraft is in GPS mode, it can achieve accurate hover of the aircraft. When the GPS signal is weak, the aircraft will automatically enter Altitude Mode or vision positioning mode.

Altitude Mode:

In Altitude Mode, when the visual positioning conditions are satisfied, the aircraft will automatically enter the visual positioning mode, in the visual positioning mode, the aircraft can hover stably with the vision positioning system.

When the visual positioning condition is not satisfied, the aircraft will hold the current altitude by barometer. Accurate hover can not be achieved, as the aircraft has possibility to drift horizontally and it requires user with skilled flight control.

Aircraft LEDs and Status Indicator

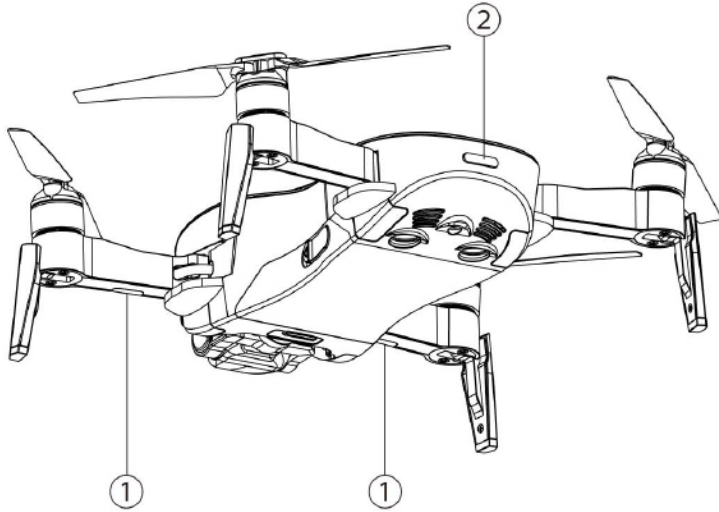

Pic. 13

Vision Positioning Status Indicator – LED ①

NO.	LED Status	Meaning
1	Flashing red light	Vision positioning failure
2	Solid red light	In vision positioning

Flight Status Indicator – LED ②

NO	LED Status	meaning
1	Solid blue light after power on	System self-diagnostic tests
2	Solid green light	Remote controller connected; GPS positioned
3	Flashing green light	Remote controller connected; GPS not positioned
4	Red and blue light flashes alternately	Aircraft is in compass horizontal calibration.
5	Red and green light flashes alternately	Aircraft is in compass vertical calibration.
6	Flashing blue light	No remote control signal, GPS not positioned
7	Solid blue light	Remote controller not connected; GPS positioned
8	Solid red light	Serious error
9	Flashing red light	Low battery alarm
10	Red light flashes doubly	Alarm for severe low battery
11	Green light flashes doubly	Beginner mode (GPS not positioned)
12	Blue and green light flashes alternately	Compass data error

Remote Controller Status Indicator

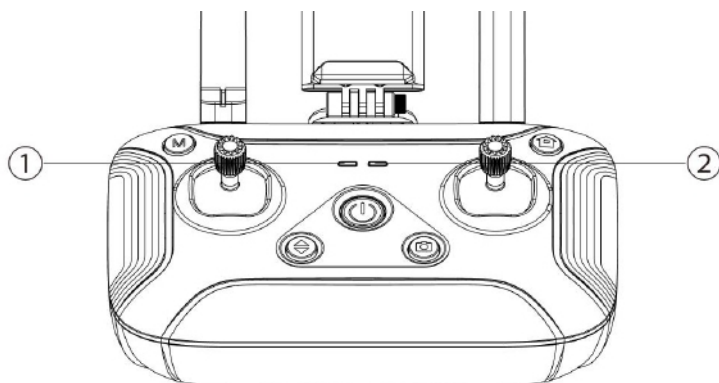

Pic. 14

Flight Mode Indicator -- LED①

NO.	LED Status	Sound	Meaning
1	Solid green light	N/A	GPS Mode
2	Solid red light	N/A	Attitude Mode

Power Indicator -- LED②



NO.	LED Status	Sound	Meaning
1	Flashing green light during charging	N/A	In charging
2	Solid green light during charging	N/A	Charging complete
3	Solid green light	N/A	The remote controller is working normally
4	Red light flashes slowly	B-B-B-.....	Low battery alarm; please charge immediately
5	Red light flashes quickly	B-B-B-.....	Severe low battery alarm; the remote controller will shut down automatically after the light flashes and the sound stops
6	Solid red light	N/A	Serious error
7	Green light flashes doubly	BB-BB-BB-.....	The remote controller is idle for more than 5 minutes after power-on; the prompt disappears automatically once operate the remote controller again

Return to Home (RTH)

Aircraft has Return-to-Home (RTH) function, and there are 3 types of RTH: one-key RTH, low battery RTH and lose control RTH. When the GPS signal is good and the aircraft successfully records the return point, if the user turns on One-key RTH, or the aircraft triggers low battery RTH, or the communication signal between the remote controller and the aircraft is lost, the aircraft will automatically return to the return point and land.

Before the aircraft takes off, when the aircraft status indicator turns green and the GPS mode is displayed on the APP, the current position of the aircraft will be recorded as the return point.

One Key RTH

When the GPS signal is good (the aircraft status indicator is solid green), the aircraft can return to the return point via the “” button on the remote control, and the return process is the same as lose control RTH. The difference is that when the aircraft returns and begins to land, the user can control the aircraft through the joystick to avoid obstacles and change the landing position. After pressing and holding the “” button for more than 2 seconds to exit the return, the user can regain control of the aircraft.

Low Battery RTH

During the flight, when the red light of the aircraft status indicator flashes slowly, the aircraft triggers low battery RTH. During the landing, the user can control the aircraft by joystick to avoid obstacles and change the landing position.

Lose Control RTH

When the GPS signal is good (the aircraft status indicator is solid green), the compass is working normally, and the aircraft successfully records the return point, if the remote control signal continues to be lost for more than 2 seconds, the flight control system will take over the control of the aircraft and control the aircraft to fly back to the last recorded return point. If the signal of the remote controller is restored later during the flight, the return process will continue, but the user can cancel the return and regain the control of the aircraft through the RTH button “”.

Attentions :

- The aircraft cannot avoid obstacles when it is flying back during the RTH process.
- The aircraft cannot return to the Return Point if the GPS signal is weak or unavailable.
- During RTH process, when the aircraft is flying above 30 meters, the aircraft will immediately perform the RTH function; when flying below 30 meters, the aircraft will rise to 30 meters automatically and then perform the RTH function.
- If the aircraft does not receive the satellite signal or the signal of the remote controller continues to be lost for more than 2 seconds, the aircraft will not be able to return, and will slowly descend until it lands.

Vision Position System

Consisted by ultrasonic sensor ① and camera ②, The vision system is composed by vision sensor and ultrasonic sensor, The position information of aircraft can be obtained by vision sensor, and the current height can be judged by the ultrasonic sensor, so that the precise positioning and safe flight of aircraft can be ensured.

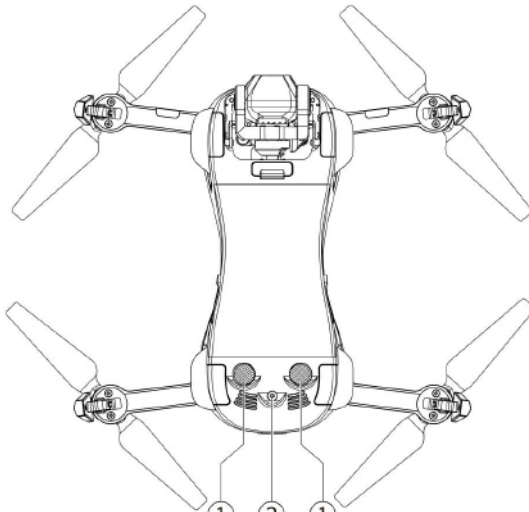

Pic. 15

Vision Positioning System

The Vision Positioning System is typically used in indoor environment when GPS is weak or unavailable. It works best when the aircraft altitude is less than 3 meters.

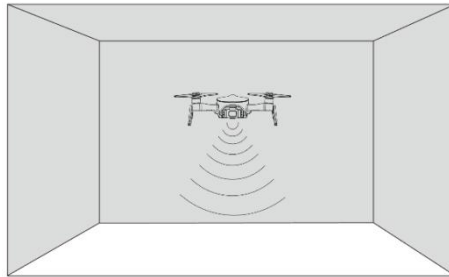

Pic. 16

The precision of the vision system is easily affected by the light strength and features of the surface textures. It would happen if the ultrasonic sensor could not work normally to detect the altitude when it is flying over objects that is made by sound-absorbing materials. Once the vision sensor and ultrasonic sensor are both not available, aircraft will switch to altitude mode automatically. Be cautious to operate the aircraft in the following situation:



- Fly fast at an altitude below 0.5m.
- Fly over monochrome surfaces (like pure black, pure red, pure red and pure green).
- Fly over strong light reflective surfaces or surfaces prone to reflection.
- Fly over water or transparent object surfaces.
- Fly over moving object surfaces (such as crowds, swaying juggles and glass).
- Fly over an area where light changes dramatically and rapidly.
- Fly over surfaces extremely dark ($\text{lux} < 10$) or extremely bright ($\text{lux} > 10,000$).
- Fly over material surfaces that absorb ultrasonic waves (like thick carpet).
- Fly over surfaces without clear textures.
- Fly over surfaces with highly repeating textures (small grid brick in the same color).
- Fly over surfaces that are tilting over 30 degrees (could not receive the echo of the ultrasonic wave).
- Flying speed should be controlled not to be too fast. When the aircraft is 1 meter against the ground, the flying speed should not be over 5m/s; When the aircraft is 2 meter against ground, the flying speed should not be over 14m/s.
- Keep sensors clean at all the time.
- The vision system is only effective when the aircraft is within the altitude of 3 meters.
- Make sure that the light is bright enough and the surfaces is with clear textures so that the vision system can acquire the movement information through recognizing the ground

textures.

- The vision system may not function properly when the aircraft is flying over water, low light ground and surfaces without clear patterns or textures.
- Do not use other ultrasonic device with a frequency of 40KHz when the vision system is in operation.

Aircraft Power Switch

Aircraft Power On/Off

Press and hold the power switch of the aircraft for about 2 seconds, the aircraft will power on. At this time, the aircraft will sound a tone, and the front and rear lights will be on; press and hold again the power switch for about 2 seconds, the aircraft will power off, and the front and rear lights will be off.

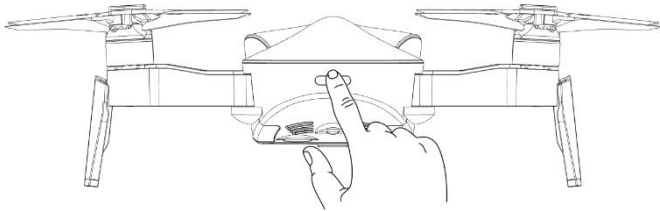

Pic. 17

Aircraft Battery

The aircraft battery capacity is 2400mAh, and its rated voltage is 11.4V. This battery uses high-energy battery cells.

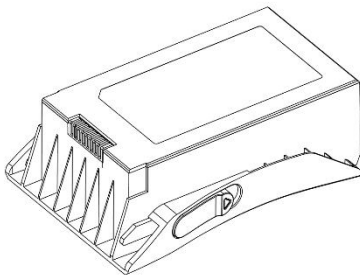

Aircraft Battery

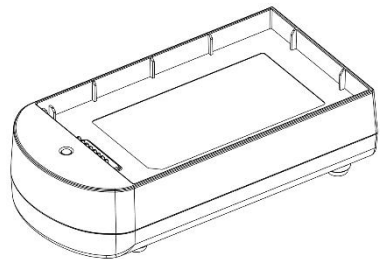

Balanced Charger

Pic. 18

Pic. 19

Check Battery Life

Insert the aircraft battery into the charger (do not connect to the power supply), user can see the current battery power by the status of the indicator light of the charger as shown:

Battery power < 25%

 25% - Battery power < 50%



Pic. 20

Charging

Be sure to fully charge the aircraft battery each time before flight. The aircraft battery must be charged using the officially supplied dedicated charger. With 5V 2A adaptor, the charging time is about 270 minutes.

Please charge the battery as the following steps:

Step1: Connect the USB power adapter and the battery balanced charger with a USB cable;

Step2: Connect the USB power adapter with a household power outlet;

Step3: Insert the flight battery into the balanced charger and make sure the connection is secure.

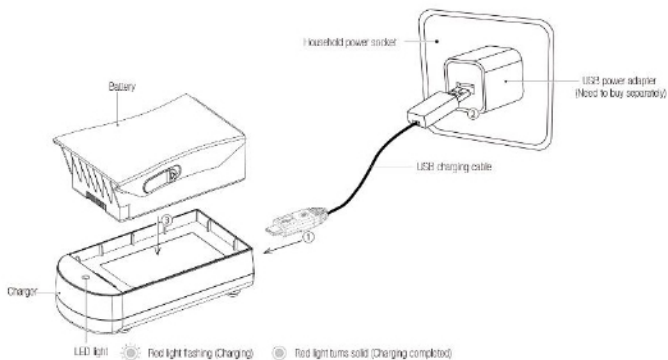

Pic. 21

Attention:



- **Adult supervision is needed when the aircraft is charging. Batteries are only to be charged under adult supervision.**
- **Do not short circuit and squeeze the battery to avoid explosion.**
- **The battery should not be short-circuited, decomposed or put into the fire; and the battery should not be placed in high temperature and heated places (such as in the fire or near the electric heating device).**
- **The model can only use the recommended charger. Regular checks should be made to check whether the charger's wires, plugs, housing and other components are damaged. When damaged, the charger should be stopped using until repaired.**
- **Charger is not a toy; charger can only be used indoors.**
- **After the flight, the battery needs to be charged before storing. If not using it, it is recommended to charge the battery at least once a month to avoid permanent battery damage due to excessive discharge.**
- **Only 5V USB power adapters that meet local laws and regulations can be used.**

Attach and Detach the Propellers

Attach/Detach the Propellers

The propellers are pre-installed in the package. If the propeller is damaged during using, please replace the propellers according to the following steps:

Detach the Propellers

Loose the two screws in the aircraft arm counterclockwise with the hex key included in the package, and then slowly pull the propeller out.

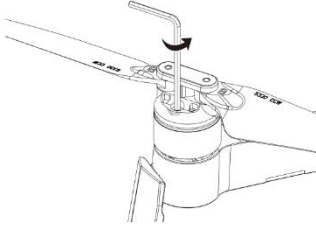

Pic. 22

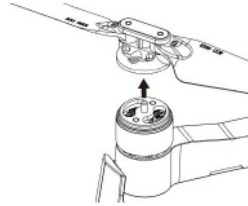

Pic. 23

Attach the Propellers

Please install the propeller A into the arm A, and propeller B into the arm B. Insert the propeller into the shaft and align the two holes on the propeller to those on the shaft. Then tighten the two screws clockwise with the hex key.

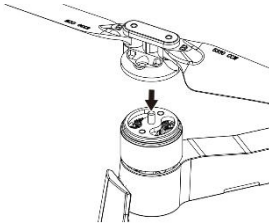

Pic. 24

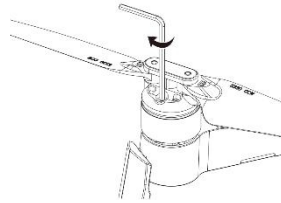

Pic. 25



- Make sure that the propeller A and propeller B are installed in the correct positions. The aircraft will fail to fly normally if the propellers are installed improperly.
- As the propellers are thin, be careful when installing them to prevent accidental scratches.
- Please use the official dedicated propellers for replacement.
- Propellers are consumables. Please purchase the official dedicated propellers if necessary.

Remote Controller

Power On and Power Off

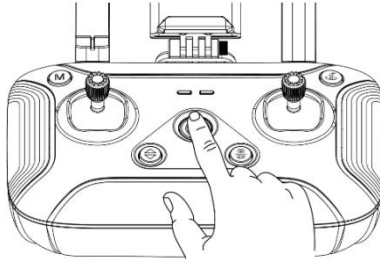

Pic. 26

Power on and power off the controller by pressing the power button for more than 2 seconds

Battery Life Check and Battery Charge

After turning on the remote controller, observe the status of the indicator. When the indicator light is always green, the battery is sufficient; when the indicator light is flashing green, the battery is insufficient.

Charge the battery according to the following steps:

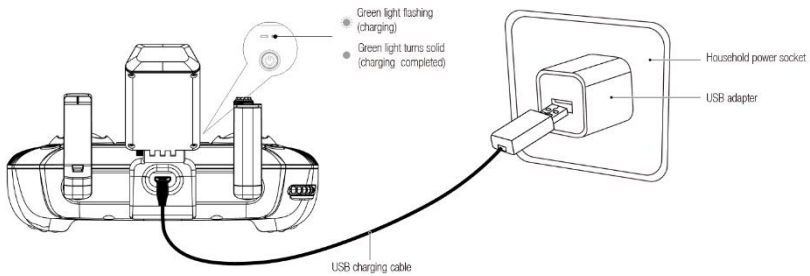

Pic. 27

Function and Status of Remote Controller

Flight Mode Switch

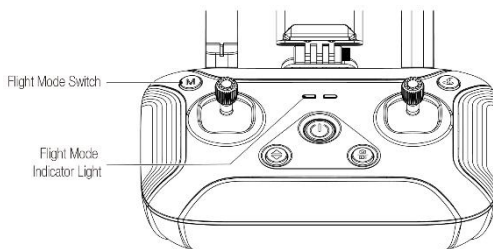

Pic. 28

Press the "M" button to switch the flight mode of the aircraft. The flight mode indicator light indicates the current mode.

LED Status	Sound	Meaning
------------	-------	---------

Solid green light	N/A	GPS Mode
Solid red light	N/A	Attitude Mode

Gimbal Adjustment

The shooting angle of the camera can be adjusted for better aerial photography experience. As shown in the figure below, dial the pulley in the upper left corner of the remote control to control the camera pitch angle.

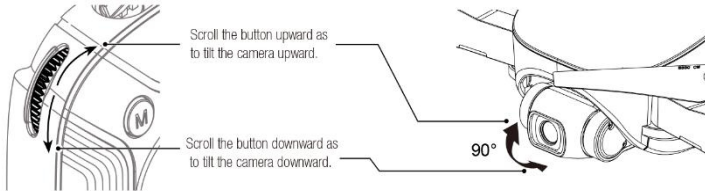

Pic. 29

Photo/Video

Short press“

Long press“

Long press“

Photo / Video

Pic. 30

- **Attention:** When the aircraft is not inserted with TF card or the TF card malfunction, the photos and videos will be stored on the mobile device, the quality of video files is relatively poor.
- Please stop recording before turn off, otherwise it will cause file damage.
- Pictures can not be taken when it's recording.

One-Key Takeoff/Landing

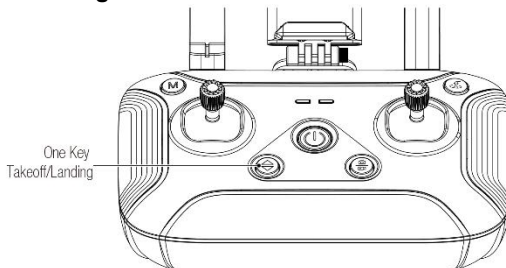

Pic. 31

Long press the "One Key Takeoff/ Landing" button for 2 to 3 seconds. When the remote controller beeps steadily, the aircraft will automatically take off and ascend to the altitude of 1.2 meters and hover.

Long press the "One Key Takeoff/ Landing" button for 2 to 3 seconds. When the remote controller

beeps steadily, the aircraft will land vertically.

One-Key RTH

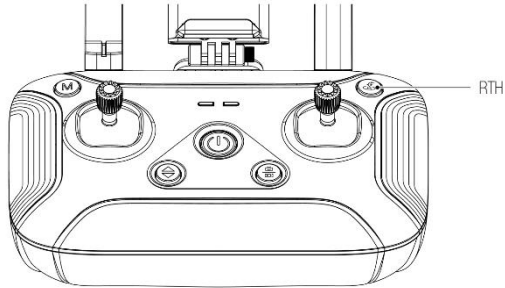

Pic. 32

Long press "RTH" button, with "B-B-" sound on RC, to start the RTH. The aircraft will fly back to the latest recorded return point. The joysticks can not be used during the process of ascent and return. During its landing, user can toggle the joystick to control the aircraft and decide the landing site. During its return, press the "Return" button again to exit RTH mode. Then the user will regain control of the aircraft.

Attention : To ensure the return to home point as precise as possible, please fly the aircraft in open area (no tall buildings in 50 meters of radius, flat in 10 meters of radius) with the GPS working well. Then the return to home function will be able to activate.

- With the GPS positioning mode turned on, it will automatically enter auto return to home mode if the remote controller loses control.
- Once the RTH mode is enabled, if the aircraft flies below 30 meters of altitude, the aircraft will automatically ascend to 30 meters before returning to home point. if the aircraft flies over 30 meters of altitude, the aircraft will return to home point at the current altitude. Please do not use other functions during the process of return. Please ensure there are no obstacles in way of return in case of any potential accidents.

Optimal Transmission Zone

Please fully extend the antennas before the flight. The signal is weak directly above the antenna. The signal between the aircraft and the remote controller is most reliable when the antennas are positioned in relation to the aircraft as depicted below.

Ensure that the aircraft is flying within the optimal transmission zone. To maintain optimal transmission performance, adjust the remote controller and antennas and keep the space between controller and aircraft clear during the flight.

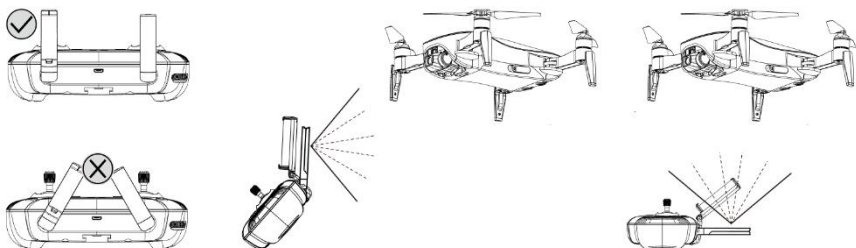

Pic. 33

Throttle Control Stick Mode

Throttle Control Stick Mode

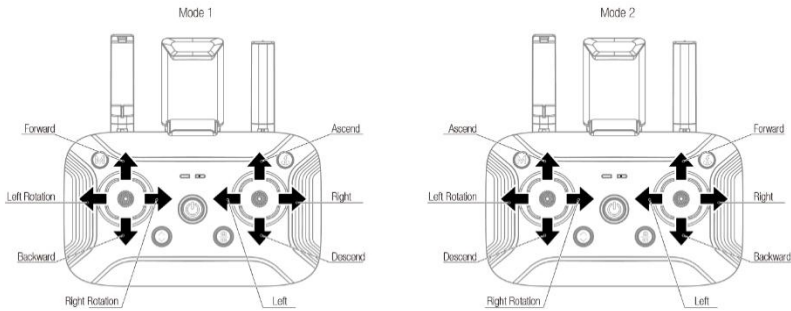

Pic. 34

Mode 2 / Mode 1 Switch

Switch to Mode 2

Toggle the left joystick ① to the lowest position and press the "One-Key Takeoff/ Landing" button ② at the same time. Then turn on the remote controller ③. Release the joystick ① and the button ② to enter Mode 2.

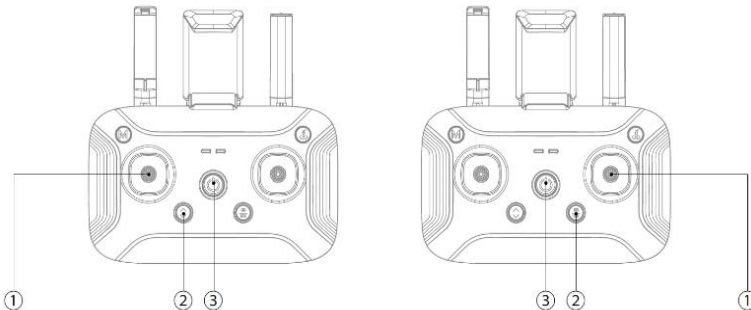

Pic. 35

Switch to Mode 1

Toggle the right joystick ① to the lowest position and press the "Photo/ Video" button ② at the same time. Then turn on the remote controller ③. Release the joystick ① and the button ② to enter Mode 1.

Mounting the Phone Holder

1. Insert the phone holder into the slot on the back of the remote controller.
2. Mount the phone into the phone holder.
3. Adjust the phone and antenna until the phone is fixedly mounted .

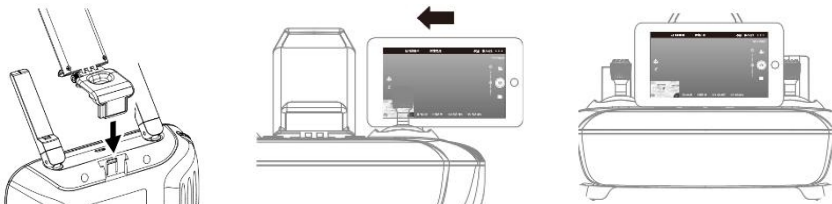

Pic. 36

Pic. 37

Pic. 38

Download APP

Be sure to connect the APP before flying the aircraft. User can control the flight, operate the gimbal/camera and set flight parameters of the aircraft via the APP.

Scan the QR code to enter the application market to obtain the download address:



Google Play



APP Store

Pic. 39

- Please make sure that the mobile software environment is Android 5.0 or above and IOS 9.0 or above, otherwise the APP may not be installed successfully or may work with errors.
- When using the APP, make sure that device supports 5GHz Wi-Fi, otherwise, it will not be able to connect to the aircraft.

Photos and Videos Saving.

If a SD card is not installed, the video and photos will be saved to the mobile app. In this case, the video quality is relatively poor (not recommended).

If a SD card is installed in the aircraft, the videos and photos will be saved to the SD card. In this case, the video quality is much better (recommended).

The videos and photos on the SD card can be transferred to the mobile APP.

Note: Only mobile phones with 5G Wi-Fi can support FPV transmission connection.

- The FPV transmission quality and distance varies by different mobile phones and different environmental situations.



environment.

- Please fly the aircraft in an open and undisturbed environment as possible for a better FPV transmission experience..
- The actual test indicates that the maximum FPV transmission distance approach 1200 meters in an interference-free

Flight

Flight Environment Requirements

1. Do not fly the aircraft in bad weather such as high winds, snow, rain, foggy weather, etc.
2. Choose a wide, open place with no tall buildings surrounded as a flight site. Buildings that use a lot of steel bars may affect the compass work and block GPS signals resulting in poor positioning or even inability to locate the aircraft.
3. When flying, please keep aircraft in sight, away from obstacles, crowds, water, etc.
4. Do not fly in areas that have high-voltage lines, communication base stations or transmission towers, etc. to avoid signal interference of the remote controller.
5. When flying above 6000m altitude, the performance of the aircraft battery and power system will be degraded due to environmental factors, thus the flight performance will be affected. Please fly with caution.
6. GPS is not available for flight in Arctic Circle and Antarctic Circle.

Flight Restrictions and Flight Limits of Special Area

According to the air traffic control regulations and the drone management regulations of ICAO and different nations' air traffic control, drones must fly in the prescribed airspace.

Pre-Flight Inspection

1. make sure the remote controller, aircraft battery, and mobile device are fully charged;
2. make sure the propellers intact and installed correctly;
3. Make sure that front and rear arms and the blades are fully unfolded;
4. Make sure that the camera lens is clean;
5. Make sure the TF card installed correctly;
6. Ensure that the battery is firmly installed;
7. Always use original components or accessories certified by the Manufacturer. The use of non-original accessories may pose a hazard to the use of the aircraft.

Test Flight

Advice for Beginners

Thank you for purchasing the product. Please read the following instructions carefully before flying to avoid those common improper operations that may damage the aircraft.

It is highly recommended to use the Beginner Mode, in which the flying height of the aircraft will be limited to 30 meters and the distance will be limited to 50 meters (the height/distance limitation can be manually adjusted), and the aircraft can only take off if there is a good GPS signal. If user are already familiar with the operation of the aircraft, user can turn off the Beginner Mode in the "General Settings" menu of the app.

Please always control the aircraft within a visible range. When the aircraft is under Positioning Mode and the FPV transmission is choppy and even lost, please activate the RTH function to return the aircraft automatically. Operating the remote control without knowing the aircraft position and the surroundings will result in a high possibility of crashing.

If user is not familiar with the manual takeoff and landing of the aircraft, it is recommended to use the one-key takeoff and landing function, then the aircraft will automatically takeoff or land.

If user are not familiar with the joystick operation, please move the joystick slightly and carefully. Any slight movement of the joystick will result in significant movement of the aircraft.

Please always pay attention to the heading of the aircraft. The direction controlled by the joystick is always the same as the direction of where the aircraft camera is. For example, if the aircraft

camera is facing user, push the joystick forward and the aircraft will fly towards user; push the joystick to the left and the aircraft will fly to the right ... same as other cases.

Beginner's Mode

For beginners, please turn on the beginner's mode. Once the mode is activated, the aircraft will locate its own position by GPS before ready to takeoff. If the aircraft can not be controlled after takeoff, the RTH can be used to allow the aircraft to return automatically.

Pairing Remote Controller and Aircraft

The aircraft is pre-paired with the remote controller in the package, users can use it once turn it on. However, if the remote controller is replaced or for other reasons that causes a failure in matching the aircraft and the remote controller, please complete the binding as the following steps:

1. Turn on the power switch of the aircraft and the remote controller;
2. Turn on phone and go to the "Settings - Wireless LAN" menu to check the current list of Wi-Fi sources. In this case, user will find the aircraft's Wi-Fi signal: Drone-xxxxxx (serial number including letters and numbers), and the remote's Wi-Fi signal: Controller-xxxxxx (serial number including letters and numbers). Please record the serial number of the remote controller ;
3. Select the aircraft's Wi-Fi signal and connect it;
4. Enter the APP interface and tap "... " button in the upper right corner to enter the "General Setting" menu;
5. Tap "Pair" in the "Pair RC ";
6. In the dialog box that pops up (Pic. 41), fill in the serial number of the remote controller user previously recorded. After confirming the serial number, tap "Pair";

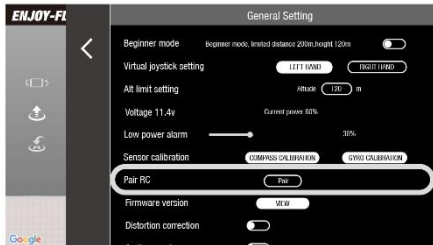

Pic. 41

7. Go to the "Settings - Wireless LAN" menu of the mobile phone again to check the serial number of the aircraft and the remote controller. If the serial number is the same, the binding has been completed. In this case, the LED indicator of the aircraft's rear arm will become flashing green or solid green.

Aircraft Self-Diagnostic Tests

When the aircraft and Remote controller are connected successfully, the status indicator turns solid blue which means that the aircraft enters the self-diagnostic tests procedure. At this time, please ensure that the aircraft is statically placed on the horizontal ground.

During the self-diagnostic tests of the aircraft, situations like environmental vibrations may cause the aircraft and the gimbal to work abnormally. If this phenomenon occurs, please power off the aircraft and put it on the stationary horizontal ground to restart it, and the aircraft will return to normal working condition.

Aircraft Compass Calibration

The aircraft has a built-in compass that ensures that the aircraft maintains an accurate heading during intelligent flight. The compass status must be checked before each flight.

○ **If encounter the following situations, please recalibrate the aircraft compass:**

1. Before the flight to a new flight site;
2. When the aircraft status indicator shows that the compass has errors;
3. When the APP and the aircraft remind to calibrate the compass;
4. When the aircraft experiences severe shifting during hovering or flying.

○ **Compass Calibration via APP:**

1. Enter Calibration Mode:

After the aircraft is connected to the APP, tap the “...” button in the upper right corner of the APP control interface (Pic. 42) to enter the “General Settings” menu (Pic. 43).



Pic. 42

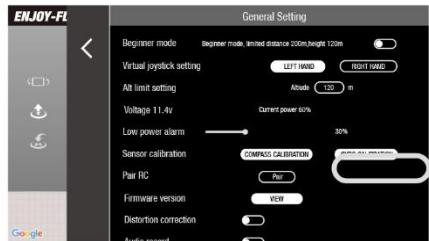

Pic. 43

Then tap the " Compass Calibration " button.

When the APP pops up a prompt, check the current environment and keep away from metal objects as prompted. Then tap the "Calibration" button (Pic.44).

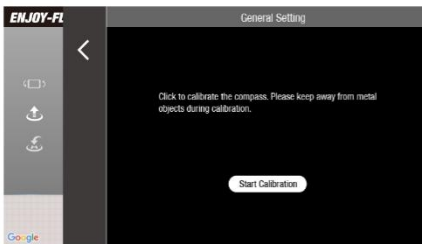

Pic. 44

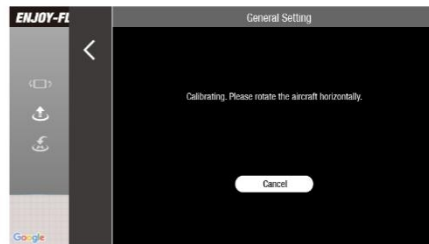

Pic. 45

In this case, when the status indicator on the rear arm of the aircraft flashes blue and red alternately, the compass calibration mode starts. At this time, the APP interface displays as Pic. 45.

2. Compass Calibration

There are two steps for compass calibration.

Step 1: Horizontal Calibration

When the APP prompts to rotate the aircraft horizontally, place the aircraft horizontally in the hand, then turn the aircraft horizontally until the status indicator on the rear arm of the aircraft changes to an alternatively flashing red and green light, which means that the horizontal calibration is successful.

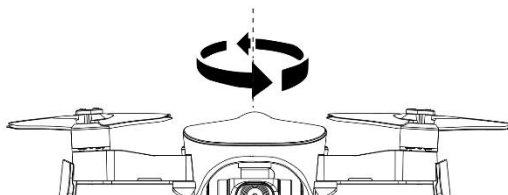

Pic.46

Step 2: Vertical Calibration

As shown in Pic. 47, when the APP prompts to place the aircraft's head to be up and rotates, place the aircraft in the hand as shown in Pic. 48 and ensure that the aircraft body is perpendicular to the ground; then rotates the aircraft horizontally.

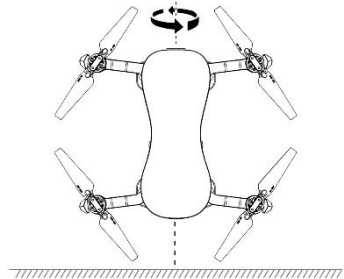
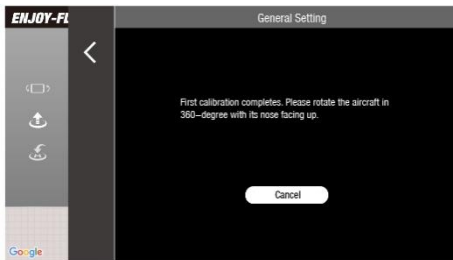

Pic. 47

Pic. 48

When the status indicator on the rear arm of the aircraft turns green (solid or flashing), the compass is successfully calibrated.

At this time, the APP will prompt “Calibration Successful”, then tap “Finish” to end the calibration process. If the status indicator turns to solid red light for about 6 seconds, the compass calibration fails. Please go to another location and recalibrate.

Note: After changing the flight site, make sure to calibrate the compass before the first flight.

- If the aircraft's LED indicator flashes blue and green alternately during flight, which means that the compass is abnormal and need to calibrate.
- Stay away from the environment with magnetic interference when calibrating, otherwise the calibration may fail.
- Do not calibrate in areas with strong magnetic fields, such as magnetic mines, parking lots, and building areas with underground reinforcement.
- Do not calibrate with carrying ferromagnetic materials such as keys, mobile phones, etc.
- Do not calibrate when large pieces of metal are nearby.

Basic Flight Operation Steps

1. Place the aircraft in a wide open area that its front is user's front.
2. Turn on the aircraft and remote controller.
3. Connect the remote controller with the aircraft and then proceed aircraft self-diagnostic tests.
4. Connect the APP with mobile device and enter into the FPV interface.
5. Unlock the aircraft after the app indicate:ready go.
6. Pull up the throttle stick then the aircraft takes off, and control the aircraft flight by left/right stick.
7. Pull down the throttle stick to land the aircraft.
8. Pull down the throttle stick to the bottom position and keep for 3 seconds to lock the aircraft.

9. Pull out the battery from the aircraft and then turn off the remote controller.

Video Suggestion and Tips

1. Make sure components of the aircraft are normal before flight;
2. Choose sunny, windy weather for recording
3. Perform test flights to establish flight routes and to preview scenes;;
4. Push the control stick gently to keep the aircraft movement smooth and stable;
5. Choose appropriate gimbal shooting angle
6. Try to record the videos under Positioning Mode

Remote Controller to Control Flight

Power on

Put the aircraft on the flat surface, turn on the Remote controller and aircraft successively, wait for aircraft on flat ground for about 30 seconds for self-diagnostic tests.

When the aircraft's indicator light turns from flashing or solid blue to flashing or solid green, which means the Remote controller and aircraft are connected.

Connect APP

Click WLAN setting, and click "Controller-XXXXXX", exit Settings Options after Wi-Fi Connection Successfully

Open the APP, enter the home page as shown, When the bound interface pops up, please tap "Check" then tap "Start Flying" to enter the flight operation interface, watch real-time images or perform necessary operations.



Pic. 49

- Connecting Controller -xxxxxx Wi-Fi, the distance between control and image transmission is relatively long, which is suitable for long-distance flight.
- Please maintain the current wifi connection and not switch to the mobile network.
- Only mobile phones with 5G Wi-Fi can support FPV transmission connection.
- Use APP to monitor the image and the current state of the aircraft.
- The remote controller with APP function will achieve the best effect. The remote controller is mainly used to control basic flight, The APP can achieve other functions, such as taking photos or videos, track mode, orbit mode or waypoint flying mode. If user hope to control aircraft via app, please refer to the "Fly with the APP" below in this manual.

GPS Signal Status

When the status indicator of the aircraft is solid green, it indicates that the GPS positioning is normal, and the aircraft can take off safely.

When the green light flashes on the aircraft status indicator, it indicates that the GPS signal is weak or no signal, and altitude mode can be selected for operation (this mode is difficult to operate, it is not recommended for beginners to use).

- Set the drone up and get ready to takeoff after the aircraft's indicator light turns solid green (indicating good GPS signal).
- Please choose an open and spacious field. Tall steel structures and metal materials will interfere the compass and GPS.

Operate the Aircraft

Takeoff

Method 1: takeoff manually

Toggle the left and right joysticks outward for at least 3 seconds (shown as the picture) as to get the propellers started to rotate.

Method 2: one-key takeoff

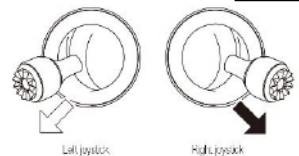

Pic. 50

Long press the "One Key Takeoff/ Landing" button for 2 to 3 seconds. When the remote controller beeps steadily, the aircraft will automatically take off and ascend to the altitude of 1.2 meters and hover.

Flight Control by Remote Controller

After takeoff, control the flight of the aircraft as shown.

Mode1

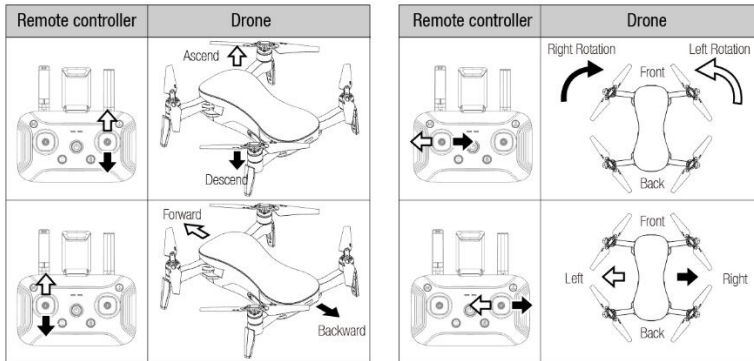

Pic. 51

Mode2

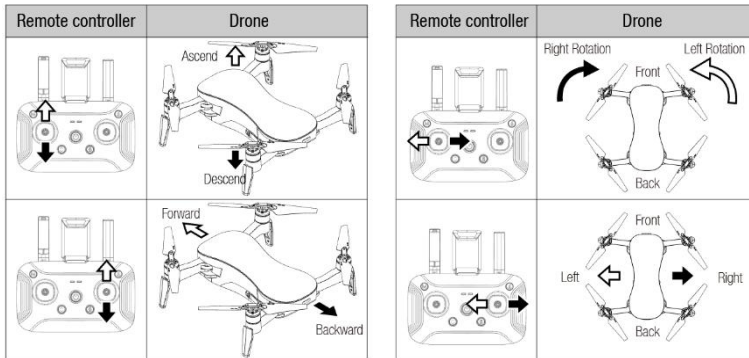

Pic. 52

Landing

Please be aware to avoid the crowd and obstacles, and ensure that the aircraft is hovering over the landing site before landing. Choose an open and flat space as landing site.

3. Method 1: land manually

Slowly toggle the throttle joystick to control the aircraft to land. When the drone lands on the ground, continue to toggle the joystick towards the lowest position until the propellers stop rotating.

4. Method 2: one-key landing

Long press the "One Key Takeoff/ Landing" button for 2 to 3 seconds. When the remote controller beeps steadily, the aircraft will land vertically.

Power off

After completing the flight, turn off the aircraft first and then the remote controller.

Use APP to Control the Aircraft

Power on

Put the aircraft on a flat surface, press and hold 2 seconds to turn on the drone. Wait until the aircraft on flat ground for about 30 seconds to finish its self-diagnostic tests, the aircraft status indicator will turn to flashing blue.

Connect with the APP

Open WLAN Setting, and click "Drone-XXXXXX", then exit the Setting menu after the Wi-Fi connection is successful.

Open the APP, enter the home page as shown below. When the notice of binding pops up, tap "Check" then tap "Start Flying" to enter the main interface. Then, user can monitor real-time FPV transmission or take necessary operations.



Pic. 53

- When connecting the Wi-Fi "Drone -xxxxxx", the distance between the controller and FPV transmission is much shorter.
- Please maintain the current Wi-Fi connection and do not switch to the mobile network.
- Only mobile phones that supports 5G Wi-Fi can support FPV transmission connection.
- Use the APP to monitor the FPV image and the current state of the aircraft.

Select Control Mode

The default setting mode is Mode 2, and user can change the mode on "..."

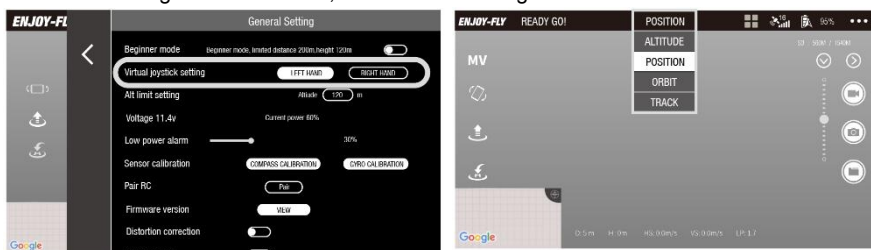

Pic. 54

Pic. 55

Select Flight Mode

The default flight mode is position mode.

For beginners, it is strongly recommended to fly under the Position Mode. With good flying skills, user can select Altitude Mode or other modes. The functions of the modes are described in the next section below.

Take off

5. Method 1: take off manually

Tap the blank area of the screen, and the virtual joysticks will pop up on the screen. Toggle the left and right joysticks outward (shown as the picture) to unlock the aircraft and the propellers will start rotating.

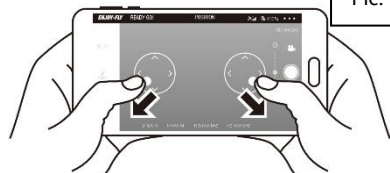

Pic. 56

Method 2: one key takeoff

Tap , it will pop up with a confirmation notice on the screen.

Tap "OK", and the propellers will speed up its rotation and the aircraft will take off.

Please stay away from the aircraft during its takeoff.

Flight Control via APP

After takeoff, control the flight of the aircraft as shown.

Mode 1

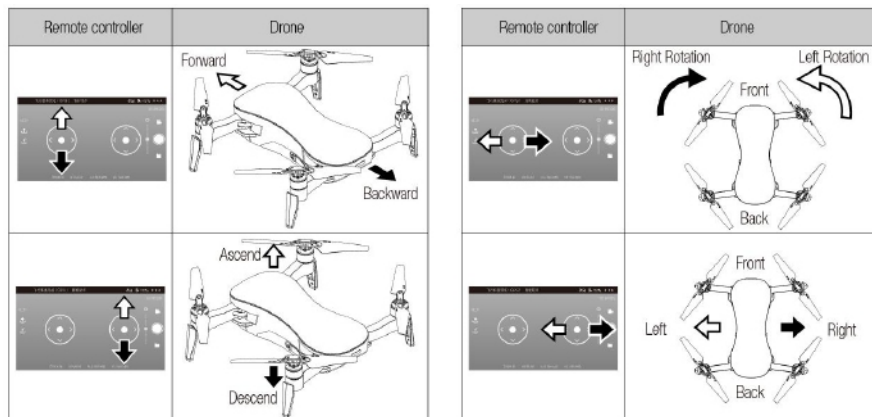

Pic. 57

Mode 2)

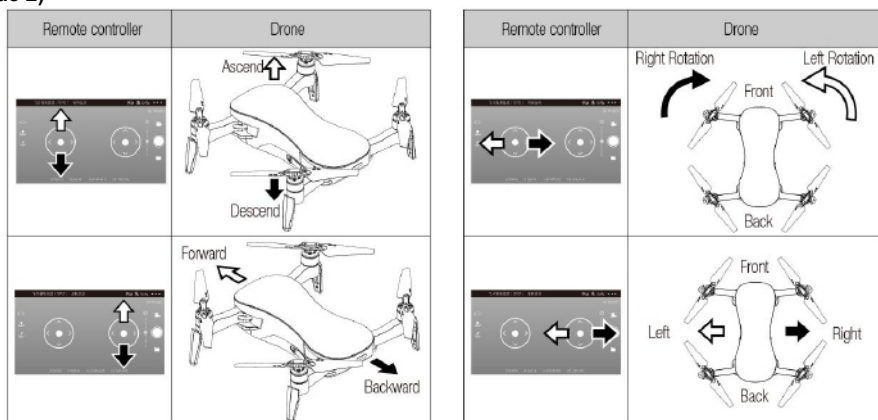

Pic. 58

Gravity Sensor Control

Tap "" to open gravity sensor mode. User can control the aircraft to move forward, backward, or to the left and right by tilting the phone forward, backward, left, and right. Tap this button again to cancel the gravity sensor mode.

This feature relies greatly on mobile phone performance, so please use this feature cautiously!!!

Warning: Please keep the phone balanced. The phone must support gravity sensor mode.

Landing

Method 1: land manually

Slowly toggle the throttle joystick to control the aircraft to land. When the drone lands on the ground, continue to toggle the joystick towards the lowest position until the propellers stop rotating

Method 2: one key landing

Tap  and it will pop up with a confirmation notice on the screen. Tap "OK", and the propellers will automatically start to land.

Please stay away from the aircraft during its landing.

Position Mode:

The default flight mode is position mode. When the aircraft is positioned (the aircraft status indicator is solid green), the aircraft will be unlocked.

In this mode, the aircraft will be positioned automatically by GPS, so it has better flight stability and safety.

- **Note: It is recommended to use the default Position Mode for the first flight and select other modes after user is familiar with the operation.**
- **Please confirm the control mode before flying.**

Altitude Mode:

In this mode, the aircraft only has vision positioning mode without GPS positioning, and the motion of the aircraft is more flexible. It needs skilled operation to control the flight of the aircraft. In the flight process, if the vision positioning condition is not satisfied (the front light flashing red), the vision positioning function fails, and the motion of the aircraft relies on manual control.

After fully mastering the operation of position mode, then user can operate under altitude mode.

One-Key RTH

If necessary, tap  to start one key RTH.

The App will pop up a confirmation notice, and after confirming that the current flight conditions meet the requirements as the pop-up notice, tap "ok".

Return-TO-Home (RTH)

If necessary, user can tap the RTH button "" to activate the automatic return function. After RTH function is activated, the APP will pop up a confirmation notice. Then user need to make sure that the current flight conditions meet the requirements as the pop-up confirmation notice and tap OK. Next, the aircraft will then return intelligently with the takeoff point as the home point. All joysticks cannot be controlled during the ascending (current height ≤ 30 meters) and the return. During its vertical landing, user can use the joysticks to control the aircraft and decide its landing position.

Press the RTH button again during return will end it and user can control the aircraft again.



RTH Button

Confirmation Notice

Forward/Backward

Pic. 59

Note: Only the aircraft is positioned by the GPS and there are no barriers around the takeoff site can ensure an accurate return position.

Warning: During GPS positioning, the aircraft will automatically enter the RTH mode if:

1) The aircraft loses connection with the mobile phone;

2) The aircraft battery is low.

In RTH mode, if the aircraft's current height is less than 30m, the aircraft will automatically rise to a height of 30m before return; if greater than 30m, the aircraft will start to return at the current height. The aircraft cannot be controlled during the return flight. Please make sure that there are no barriers in the return route to avoid accidents.

Power Off

After the aircraft lands and the propeller stops rotating, turn off the aircraft power switch (press and hold for 2 seconds).

Then exit the App.

Introduction of Main Interface

Home Page

After opening the app, user will enter the “Home Page” as shown below:



Pic. 60

αHelp Menu:

Tap to download the user instruction and other documentation.

βEnter the Main Interface:

When the APP is not connected to the aircraft, the “Interface View” is displayed; when it is connecting, “Connecting...” is displayed; after the APP is connected to the aircraft, “Start Flying” is displayed and user can tap it to enter the main interface.

χRead the “Privacy Policy”:

Tap the button to read the "Privacy Policy". Be sure to read and understand the content before using it.

δRead “User Notices”:

Tap the button to read the “User Notices”. Be sure to read and understand the content before using it.

εAPP Version:

The information is the current APP version.

Main Interface

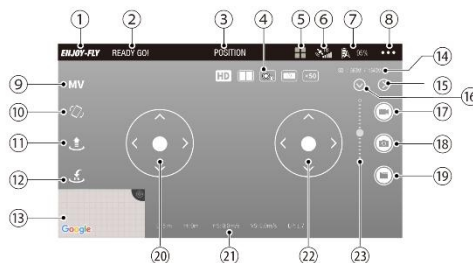

Pic. 61

αReturn to the Home Page:

Tap to return to the "Home Page".

βAircraft Status:

Displays the current status of the aircraft.

χ Flight Mode:

It displays the current flight mode. Tap to pop up the list and select preferred flight mode. Please refer to the relevant instructions of the flight modes in this manual.

δ Camera Functions Menu:

From left to right:

 Set the resolution of FPV transmission.

 VR mode.

 Main/secondary cameras switch: Select the gimbal camera or the optical flow camera.

 Flip the FPV transmission image.

 Digital zoom.

ε Camera Functions Menu Button

Tap to pop up the menu as shown in ; tap again to hide the menu.

φ GPS Signal

Display the GPS signal status of the current aircraft.

γ Aircraft Battery Status:

Displays the current aircraft battery status.

η General Settings:

Tap to enter the general settings menu.

ι Music Video (MV):

Tap to enter the "MV Video" menu. Please refer to the relevant introduction in this manual.

φ Gravity Sensor Mode:

Tap to enter the "Gravity Sensor Mode". Please refer to the relevant introduction in this manual.

κ One Key Takeoff/Landing:

It displays icon "  " before the aircraft takeoffs. Tap and the aircraft will automatically take off to a height of 1.2 meters and hover.

It displays icon "  " after the aircraft takeoffs. Tap and the aircraft will automatically descend to the ground.

λ Return-To-Home (RTH)

Enter or exit the "RTH" function.

μ Map

Tap the map to zoom in to display the area that near the aircraft's current location.

ν TF Card Status:

It displays "N/A" when a TF card is not installed. It displays the current storage status when a TF card is installed.

ο Photo/Video Menu Button:

Tap to show or hide the photo/video menu.

π Main Camera's Pitch Angle Adjustment:

Tap to show or hide the slider that adjusts the pitch angle.

θ Video Recording:

Tap to start or stop recording.

ρ Photo Taking:

Tap to take a photo.

σ Album:

Tap to enter the album to view the photos and videos user has taken.

τ Left Joystick:

Please refer to the relevant introduction in this manual.

υ Aircraft Flight Status:

From left to right:

D:x m:Relative distance between the current position of the aircraft and its takeoff point;

H:x m:Relative height between the current position of the aircraft and its takeoff point;

HS:x.x m/s:Current horizontal flight speed of the aircraft;

VS:x.x m/s:Current vertical flight speed of the aircraft;

LP:x.x: Positioning status of the mobile device.

ω Right Joystick:

Please refer to the relevant introduction in this manual.

ω Main Camera's Pitch Angle Adjustment Slider

Move the slider to adjust the camera's pitch angle.

General Settings Menu

Tap the “...” button in the upper right corner of the Main Interface to enter the “General Settings” menu as shown below.

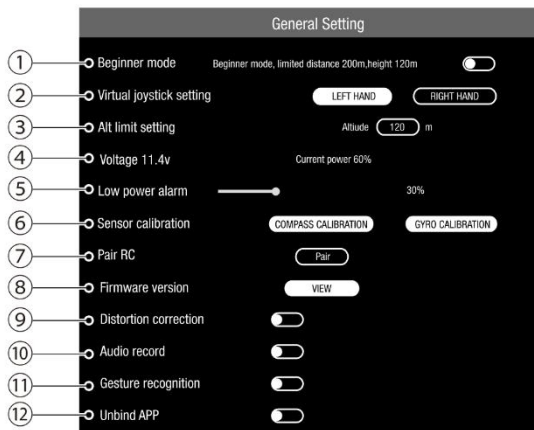

Pic. 62

αBeginner Mode On/Off

Before the aircraft takes off, the Beginner Mode can be turned on or off. The flight distance will be greatly limited under Beginner Mode.

βVirtual Joystick Setting:

Before the aircraft takes off, the virtual joysticks can be set as “Left-Hand Throttle” or “Right-Hand Throttle”.

χAlt Limit setting:

Limits the aircraft's flight height before it takes off. The default height is 120m, and it can be set to 30m~500m.

δVoltage:

Displays the current battery voltage of the aircraft.

εLow Power Alarm

User can set the limit for the battery-low alarm. The default is 10%, and the range is from 10% to 80%.

φ Sensor Calibration:

Vertical or horizontal compass calibration. Please refer to the relevant introduction in this manual.

γ Pair RC

Remote control pairing. Please refer to the relevant introduction in this manual.

ηFirmware Version:

Tap to view the current application version, flight control firmware version, relay firmware version, remote firmware version and image firmware version.

ι Audio Recording:

Turn recording on or off (off is default). When turned on, user can record the audio on the mobile phone while the aircraft camera is recording a video.

φDistortion Correction

When turned on, it will correct the distortion of the photo taken by the wide-angle lens.

κGesture Recognition:

When turned on, user can control the camera to take photos or record videos with a specific gesture. Please refer to the relevant introduction in this manual.

λUnBind APP:

Unbind the current APP from the aircraft. Only after that, other users can bind this aircraft.

Flight Modes for APP**Position Mode:**

The default flight mode is position mode. When the aircraft is positioned (the aircraft status indicator is solid green), aircraft will be unlocked.

In this mode, the aircraft will be positioned automatically by GPS, so it has better flight stability and safety.

- **Note: It is recommended to use the default Position Mode for the first flight and select other modes after user is familiar with the operation.**

Please confirm the control mode before flying.

Altitude Mode:

In this mode, the aircraft only has vision positioning mode without GPS positioning, and the motion of the aircraft is more flexible. It needs skilled operation to control the flight of the aircraft. In the flight process, if the vision positioning condition is not satisfied (the front light flashing red), the vision positioning function fails, and the motion of the aircraft relies on manual control.

After fully mastering the operation of Position Mode, user can select the Altitude Mode.

One Key RTH

If necessary, tap  to start one key RTH.

The App will popup a confirmation notice, after ensuring that the current flight conditions meet the requirements as the pop-up notice, tap “ok”.

Return-TO-Home (RTH)

If necessary, user can tap the RTH button “

Press the RTH button again during return will end it and user can control the aircraft again.



Pic. 59

Note: Only the aircraft is positioned by the GPS and there are no barriers around the takeoff site can ensure an accurate return position.

Warning: During GPS positioning, the aircraft will automatically enter the RTH mode if:

- 1) The aircraft loses connection with the mobile phone;
- 2) The aircraft battery is low.

In RTH mode, if the aircraft's current height is less than 30m, the aircraft will automatically rise to a height of 30m before return; if greater than 30m, the aircraft will start to return at the current height. The aircraft cannot be controlled during the return flight. Please make sure that there are no barriers in the return route to avoid accidents.

Orbit Mode:

In Positioning Mode, when the Orbit Mode is activated, the aircraft will rotate around its current position. At this time, controlling the aircraft to move forward or backward can adjust the orbiting radius.

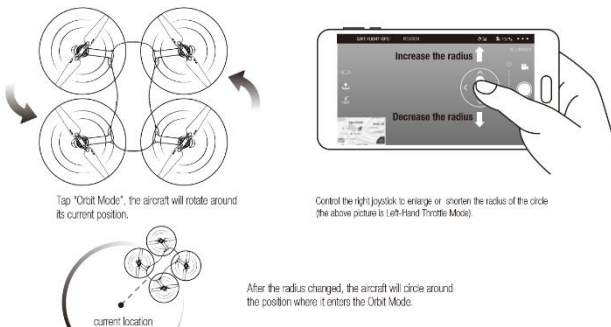

Pic. 63

Track Mode (with the GPS successfully positioned)

In Position Mode, when Track Mode is activated, the aircraft will automatically follow user's mobile device.

(1) Please pay attention to the GPS signal status in Track Mode:

Pic. 64



- Track Mode can be used when the GPS signal is full on the APP;
- Track Mode is not advised to be used when the GPS signal on the APP is not full. If user need to use it, be sure to pay close attention to the aircraft condition and the surrounding environment!
- Track Mode must not be used when the GPS signal on the APP is poor!

(2) How to track

The aircraft will target the phone and always keep the default distance (5 meters) to track.

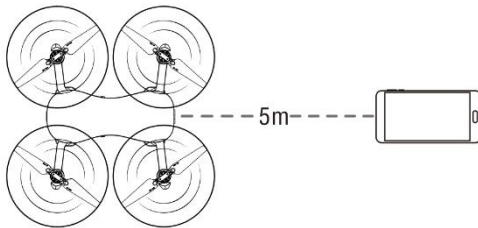

The aircraft will follow the mobile phone with 5 meters in distance.

Pic. 64

Warning: In order to ensure accurate return position, please choose a wide and open area (no large buildings within 50 meters and no barriers within 10 meters) and ensure the GPS signal is good so that the RTH function can work normally.

Ensure that the mobile phone is positioned successfully and accurately.

Waypoint Flying

Tap the map on the left corner on the APP main interface, it will pop up map / Waypoint Flying.



Pic.65



Pic.66

Ensure high battery level of the aircraft and the mobile phone before activating the Waypoint Flying mode. Tap "Waypoint Flying" or "Flight Planning" after its takeoff and read through the notice. Tap way-points on the screen and set the altitude (the default is 30 meters) on the right side of the screen. Then tap "Start" to begin waypoint flying. user will see the aircraft fly towards the pre-set points.

Tap "Stop" to exit Waypoint Flying mode. When the aircraft flies towards the final waypoint, it will hover at that point.

Warning: Please tap the waypoints within the circle (in radius of 100 meters). When the Waypoint Flying mode is turned off, the aircraft will hover. To restart it, user can tap new waypoints to turn on this mode again. During its return of landing, the aircraft will automatically exit Waypoint Flying mode and return to the home point or land on the ground.

Warning: For user personal and property safety, please use this function cautiously. Always choose a open and spacious outdoor area away from crowds to fly the aircraft. Also always pay attention to the flight environment and the flight altitude.

Photo and Video in APP

One-key photo taking/video recording:

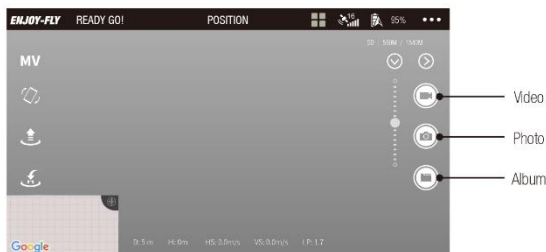

Pic. 67

Tap the “Photo” b

Tap the “Camera” button and the button will turn red to start video recording. Tap the button again, the button will change back to white, and the recording will stop.

If the TF card is installed on the aircraft, the photo and video will be stored in the TF card. Otherwise, the photo and video will be saved in the APP's photo album.

the quality of video storage files is better on SD card,

Gestures to Take Photos and Videos

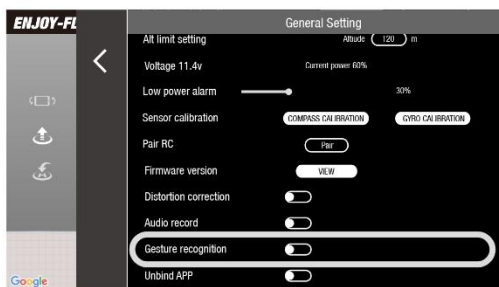

Pic.68

The aircraft has “Gesture Recognition”, and this function can be opened in the APP “General Settings” menu. During the flight, the following gestures can be made in front of the aircraft camera to control the camera to take photos and videos.

(1) Victory Gesture (Photos)

Face in front of the aircraft camera about 6 feet and make a “V” gesture with one hand. Wait until the gesture recognized, the camera will shoot automatically after 3-seconds countdown.

(2) Square Gesture (Videos)

Face in front of the aircraft camera about 6 feet and make a square gesture near user chin. Wait until the gesture recognized, the camera will start filming immediately. When the square gesture is recognized the second time, the filming will end immediately. (Interval between the first and second recognitions should be at least 3 seconds.)

Pic. 69



(3) Palm Gesture (Videos)

Face in front of the aircraft camera about 6 feet, raise user hand and close user five fingers. Wait until the gesture recognized, the camera will start filming immediately. When the palm gesture is recognized the second time, the filming will end immediately. (Interval between the first and second recognitions should be at least 3 seconds.)

Attention: To ensure a high recognition rate:

- (1) Face the aircraft camera front;
- (2) Please do it in a well-lit environment;
- (3) Face in front of the camera about 6 feet before making a gesture.

The recognition rate reduced when:

- (1) In a poor-lit or backlighting environment;
- (2) Weak Wi-Fi signal or the signal is being interfered.

Adjust the Camera's Pitch Angle by APP

Adjust the camera upward or downward to achieve the best shooting angle and to capture the perfect view when taking photos or videos.

When using the APP to control the aircraft, slide the scroll bar on the right side of the APP main interface to control the pitch angle.

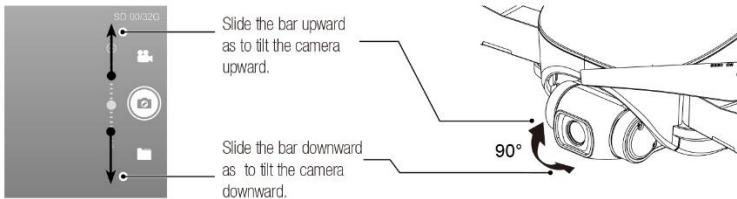

Pic. 70

Music Video (MV):

Go to the main interface of the App, tap "MV" button to enter the MV interface and edit MV.

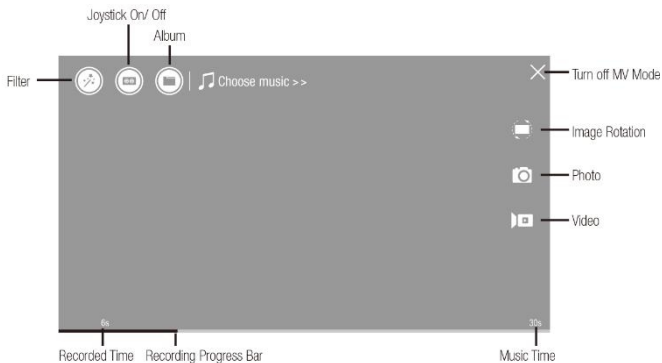

Pic. 71

Image Rotation

Tap the icon "📷" to turn on the image rotation function.

Slide finger on the screen to rotate the image. Double tap the screen to zoom the image (this operation also applies to video recording).



Please Take proper operation and flight safety guidelines in mind as it is very important for all of us.

For more information, please turn to Appendix.

Appendix

Specification

Size	Fold: Unfold:	177*90*55 mm (L X W X H) 177*196*70mm (L X W X H)
Wheelbase		216 mm
Weight (Battery & Propellers Included)		Approximately 435g
Max Ascent Speed		3 m/s
Max Descent Speed		1.5 m/s
Max Speed		8m/s (GPSmode)
Max Service Ceiling Above Sea Level		5000 m
Max Flight Time		25 min
Max Total Travel Distance		7 km
Operating Temperature		0°C~40°C
Satellite Positioning Systems		GPS/GLONASS
Hover Accuracy Range		vertical : +/- 0.5 m ± 0.2 m (ultrasonic system,optical flow system works) horizontal : +/- 1.5m ± 0.3 m (ultrasonic system,optical flow system works)
Operating Frequency		5170-5190 GHz or 5735-5755 GHz
Maximum flight height		120m , maximum 500m (need to change setting on app)

Optical flow system

Operating Environment	Surface with clear pattern and adequate lighting (lux >10)
Velocity Range	≤2m/s at 6.6 ft (2 m) above ground
Altitude Range	0.5~5m

Ultrasonic altitude system

Operating Environment	except for surface of water or ground of absorbing material (such as thick carpet)
Velocity Range	≤<2m/s
Altitude Range	0.5~3m

3-axis gimbal

Stabilization	3-axis Brushless mechanical Stabilization
Controllable Range	pitch : -90°~0°
Rotating range	Pitch : -120°~+45° Roll : -30°~+30° Course : -15°~+15°

Camera

Sensor	1/2.7" CMOS ;
lens	FOV 100
ISO range	video : 100 - 3200 photo : 100 - 1600
Image Size	4072*3096 (12mp)
Still Photography Modes	Single shoot
Video Recording	FHD : 1920x1080
Max Video Bitrate	13Mbps
Supporting file systems	FAT32 (≤32GB)
Photo	JPEG
Video	MP4
Supported SD Cards	Micro SD™ Max capacity: 32GB. Class 10 or UHS-1 rating required
Operating Temperature	0°C~40°C

Battery

Capacity	2400 mAh
Voltage	11.4 V
Type	LiPo 3S
Energy	27.36 Wh
Net Weight	Approximately 165g
Max charging power	30 W
charge time	<4.5h(with 5V 2A adapter)
Charging Temperature	0°C~40°C

APP /FPV

Mobile App	Enjoy fly
Live View Quality	720P
Delay	260 ms
Required Operating	Android 5.0 above , IOS 9.0 above
FPV transmission	1200m

Charger

Input	5 V 2A(recommend)
Output	4.35V 0.7A×3
power	10 W

WI-FI

Operating Frequency	5G Hz
Max Transmission	horizontal:200m , vertical:120m
Max Speed	10 km/h
Max Ascent Speed	2 m/s
Max Descent Speed	1.5 m/s

Remote Controller

Operating Frequency	5 GHz
Max Transmission Distance	1200 m (Unobstructed, free of interference)
EIRP	FCC : ≤ 23 dBm CE : ≤ 14 dBm SRRC: ≤ 20 dBm
Operating Current/Voltage	300-500mA @ 3.7V
Battery capacity(built-in)	2600 mAh
Voltage	3.7 V
Type	LiPo 18650 1S
Energy	9.62 Wh
Operating Temperature Range	0°C~40°C
Port types	USB
Charge	USB
Maximum charge power	5W
charge time	< 3h(with 5V 2A adapter)

Warranty Information

Please browse the official website for the latest after-sales warranty information.

Packing Detail

The whole package includes the following parts, and if there are any defects, please contact the seller or the local distributor.

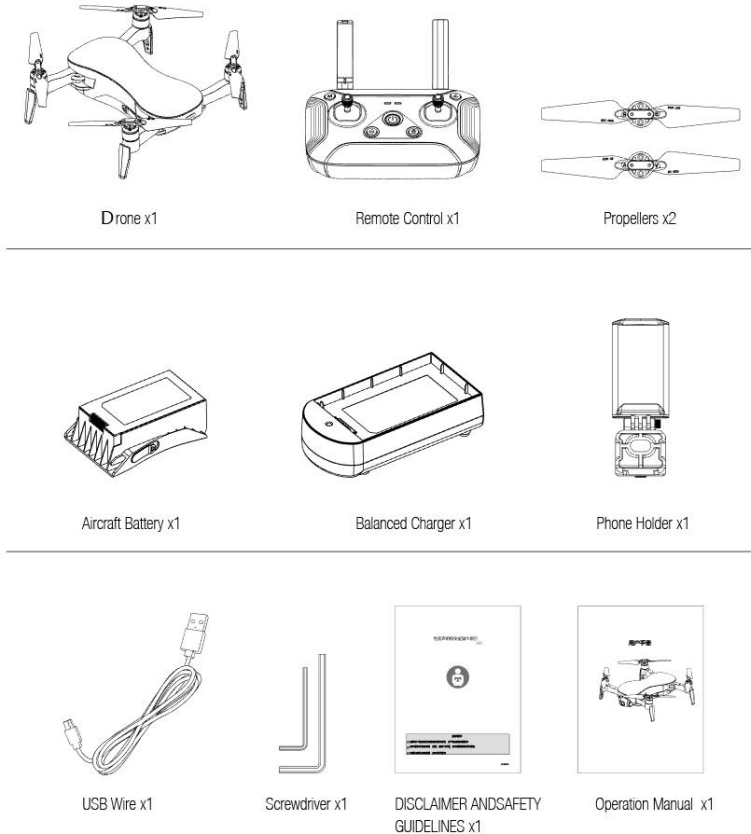

Important Statement

1. This aircraft is not a toy, but model for enthusiasts. It should be assembled and operated properly.
2. Pilot must operate this aircraft in safe way. Improper operation may cause injury or property damage
3. This aircraft is applicable for pilots aged 14+ who are with skilled flying experience
4. In case of problems such as usage, operation and maintenance, please contact the local distributor or the relevant personnel of the company. Company and distributors are not liable for any loss or damage caused by improper usage or operation and human injury.
5. Keep the small accessories away from kids to avoid accidents.

Flight Safety Guidelines

Remote control model aircraft is somewhat considered to be the highest danger potential article, so it is necessary to keep away from the crowd when flying. The unpredictable accidents such as inappropriate assembly or body damage, poor electronic control, and unfamiliar operation may result in aircraft damage or personal injury. Users should pay attention to flight safety and be aware of the responsibility for accidents caused by their own negligence.

● Stay away from obstacles, crowds

The flight speed and state of the remote control aircraft are uncertain, and there are potential dangers. Flying must be far away from crowds, high-rise buildings, power lines and so on, while avoiding flying in bad weather such as wind, rain, thunder and lightning. The debugging and installation of the aircraft must be strictly controlled in accordance with the operating instructions. Attention should be paid to keeping a distance of 1-2 meters between the aircraft and the users or other persons during flight, so as to avoid the aircraft colliding with the head, face and body of the person during flight and landing and causing injury.

● Keep the aircraft in dry environment

The aircraft is composed by sophisticated electronic components and mechanical parts. To avoid damages on the mechanical and electronic components, please keep the aircraft in dry environment

and use clean cloth to wipe the surface and keep it clean.

- Practice flying together with skillful pilot

Beginners are suggested to practice flying together with skillful pilot's guidance. Do not fly alone.

- Bear proper operation and safe flight guidelines in mind

Please take a careful look at the manuals before flights for important information of product functions and operation tips, and learn how to use the accessory, safe flight always comes first. Stay informed of and abide strictly by relevant local laws and regulations. Keep away from any non-flight zones and respect other people's privacy.

● Safe flying

Please make sure in good shape mentally before every flight. Fly the aircraft as per flying experience. Never fly under influence of alcohol or drugs. Keep the remote controller at least 20 cm away from body when flying the aircraft, do not fly it close to ears! Misuse may lead to hearing loss.

● Keep distance from a flying aircraft

Never use hands to touch a flying aircraft under any circumstance. Don't approach and touch a landed aircraft before its propellers are completely locked.

● Keep away from heat source

The aircraft is made of metal, fiber, plastic, electronic component and other material. Please keep it away from the heat source to avoid deformation or even damage caused by sun exposure and high temperature.

● Environmental protection requirements

To protect our blue planet, so please recycle the aircraft as per local laws and regulations.