

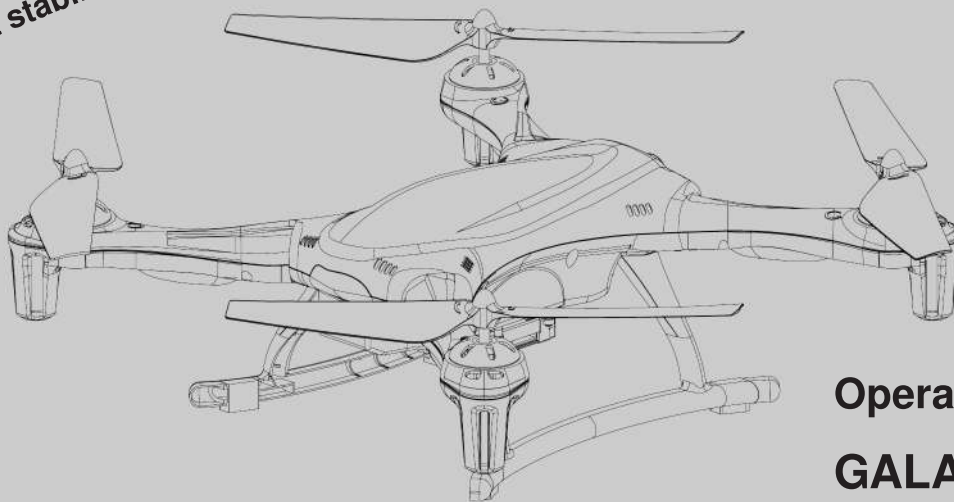

Nine Eagles™

Distributed by **robbe**

with
still photo and video function
and height stabilisation!



Operating Instructions

GALAXY VISITOR 3

RTF FTR 2.4 GHz

No. NE2529M2

No. NE2529M1



FUTABA Transmitter Ready, abbreviated to FTR, applies to selected models from the Nine Eagles range. These models' transmitter and receiver work with the FUTABA S-FHSS code, which means that they can also be controlled by FUTABA transmitters which can be operated in S-FHSS mode.

If you wish to use a radio control transmitter other than the original one, please note that those functions which are selected using the AUX buttons will not be available (mode selection, Auto-Return function and intelligent flight mode). The photo / video function can be assigned to rotary buttons and / or sliders; the method of programming is described on pages 22 / 23.

Explanation of specialist terms:

Climb and descent ("Collective pitch / throttle"): this controls the model's climb and descent.

Yaw: The model's movement around the vertical axis. The model's nose turns to right or left.

Pitch-axis: The model's movement around the lateral axis: forward or reverse flight.

Roll: The model's movement around the longitudinal axis: sideways movement to right or left.

Dual Rate: Switchable travel reduction for control movements.

Binding: Creating the radio link between transmitter and receiver.

Contents	Page
Explanation: FTR system	2
Explanation of specialist terms / Contents	3
Special features of the GALAXY VISITOR 3	4
Model description	4
Safety Notes	5, 6
Set contents / Specification	7
Transmitter layout / overview - GALAXY VISITOR 3	8, 9
Primary and expanded control function settings	10
Charging the flight battery	10
Safety Notes regarding LiPo batteries	11
Flight preparations	12
Trim adjustments	13
Basic information on flying the GALAXY VISITOR 3	14
Practice flying	15
Brake function	15
Signal Loss Protection function	16
Conventional flight mode and intelligent flight mode	16
Switching the acceleration sensor on and off	17
Meaning of and selecting the 3 throttle modes	17
"Auto-Return" function	18
Binding the transmitter and receiver	19
Calibrating the acceleration sensor	20
Dual-Rate function	21
Speed of the Auto-Return function	21
Transmitter magnet sensor	22
Camera	22, 23
After repairs	23
Replacement Parts list	24, 25
Conformity Declaration	26



Please be sure to observe the safety notes regarding the safe handling of Lithium-Ion-Polymer batteries on page 11.

Special features of the GALAXY VISITOR 3 RTF FTR

Two flight modes and three throttle modes are available:

Flight mode:

- Conventional flying and intelligent flying.

Throttle mode:

Beginner mode, height stabilisation mode and normal mode.

- A push-button on the transmitter provides a simple means of toggling between the flight modes.
- The "Headless Flight Mode" in intelligent flight mode makes it particularly easy for beginners to master the quadcopter.
- An "Auto-Return" function ensures that the quadcopter comes straight back to the pilot.
- Brake function. The copter slows down automatically when the pilot releases the sticks.

Key features:

- Anti-collision guard simply by switching the acceleration sensor on and off.
- LEDs of different colour make it simple to detect the model's attitude.
- On-board micro digital camera for video and still pictures.
- Integral height sensor.
- Signal Loss Protection function: if the signal is lost, the copter automatically hovers and lands.

Model description

The GALAXY VISITOR 3 is a 2.4 GHz mini-quadcopter of the latest generation.

The highly developed nine-axis gyro and stabilisation system is the key to the model's extremely simple method of control and accurate response. The GALAXY VISITOR 3's simple control system and good inherent stability make it an excellent choice for the beginner. This quadcopter's agility level is user-variable, and this ensures that flying the GALAXY VISITOR 3 is never boring even for advanced pilots. The model can also cope well with gentle breezes when flown outdoors. The GALAXY VISITOR 3 combines many advantages in one model, including small size, low weight and safe operation.

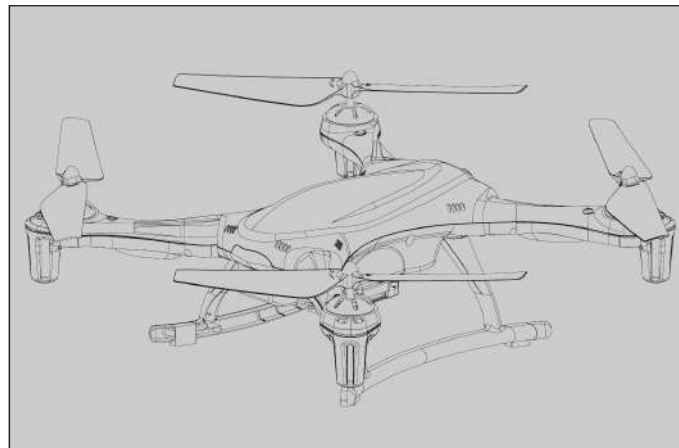

Be sure to read these Safety Notes before you assemble your model. Always keep to the procedures and settings recommended in the instructions.

If you are operating a radio-controlled model aircraft, helicopter, car or boat for the first time, we recommend that you enlist an experienced modeller to help you.

Safety Notes

Radio-controlled models are not toys in the usual sense of the term. Young persons under eighteen years should only be allowed to operate them under the supervision of an adult.

Building and operating these models requires technical expertise, manual skills, a careful attitude and safety-conscious behaviour.

Errors, negligence and omissions in building or flying these models can result in serious personal injury and damage to property.

Since the manufacturer and vendor are not in a position to check that your models are built and operated correctly, all we can do is bring these hazards expressly to your attention. We deny all further liability.



Helicopter rotors, and all moving parts generally, constitute a constant injury hazard. It is essential to avoid touching such parts.



Please bear in mind that motors and speed controllers may become hot when operating. It is essential to avoid touching such parts.



Do not stand close to the hazard area around rotating parts when an electric motor is connected to the flight battery.

You must also take care to keep all other objects away from moving or rotating parts.



Observe the instructions provided by the battery manufacturer.

Overcharged or incorrectly charged batteries may explode. Take care to maintain correct polarity.



Notes on the use of dry cells:

Do not attempt to recharge dry cells, do not open them, and do not incinerate them. Remove exhausted dry cells from the transmitter after use. Escaped electrolyte may ruin the transmitter.

Ensure the equipment is protected from dust, dirt and moisture contamination. Do not subject the system to excessive heat, cold or vibration.

Use the recommended charger only, and charge the batteries only for the prescribed period.

Check your equipment for damage at regular intervals, and replace defective components with genuine spare parts.

Do not re-use any devices which have been damaged in a crash or by water, even when they have dried out again.

Send the equipment to the robbe Service Department for checking, or replace the parts in question.

Crash or water damage can result in concealed defects which may lead to failure in subsequent use.

Use only those components and accessories which we specifically recommend.

Do not carry out modifications to the radio control system components apart from those described in the instructions.

Operating the model



Caution - injury hazard:

Please keep a safe distance away from your model aircraft. Never fly over spectators, other pilots or yourself. Always fly manoeuvres facing away from other pilots and spectators.

- Never fly close to high-tension overhead cables or residential areas.
- Do not operate your model in the vicinity of canal locks or open waterways.
- Do not operate your model from public roads, motorways, paths and squares etc.; use authorised model flying sites only.
- **Never operate the model in stormy weather.**

Insurance

Ground-based models are usually covered by standard personal third-party insurance policies. In order to fly model aircraft you will need to extend the cover of your existing policy, or take out specific insurance.

Check your insurance policy and take out new cover if necessary.

Liability exclusion:

robbe Modellsport is unable to ensure that you observe the assembly and operating instructions, or the conditions and methods used for installing, operating and maintaining the model components.

For this reason we accept no liability for loss, damage or costs which are due to the erroneous use and operation of our products, or are connected with such operation in any way.

Regardless of the legal argument employed, our obligation to pay compensation is limited to the invoice value of those robbe products directly involved in the event in which the damage occurred, unless otherwise prescribed by law. This does not apply if the company is deemed to have unlimited liability according to statutory regulation due to deliberate or gross negligence.



Set contents:

- 1 x High-end mini-quadcopter, factory-assembled and set up, ready to fly
- 1 x LiPo battery, 3.7 V / 1200 mAh with polarised connector
- 1 x 230 V battery charger
- 1 x 2.4 GHz four-channel transmitter set to Mode 2 (NE2529M2)
Mode 1 (NE2529M1) (stick mode cannot be changed)
- 4 x AA-size dry cells
- 1 x Four replacement rotors
- 1 x Screwdriver
- 1 x Comprehensive operating and flying instructions
- 1 x Camera set with SD card and card reader
Camera resolution 1280 x 720 pixels HD

Dear customer,

Congratulations on choosing a factory-assembled model quadcopter with video and photo function and height stabilisation from our range. Many thanks for placing your trust in us.

The model can be completed and prepared for flight very quickly. Please read right through these instructions before attempting to fly the model for the first time, as this will make it much easier to operate the model safely.

All directions, such as “right-hand”, are as seen from the tail of the model, looking forward.

Specification:

- Main rotor \varnothing : approx. 147 mm
- Length: approx. 163 mm
- Width: approx. 163 mm
- Height: approx. 78 mm
- Flight battery: 3.7 V / 1200 mAh LiPo
- All-up weight: approx. 135 g

RC functions:

- Pitch-axis, roll, yaw, climb / descent
- Video and still photo function

Transmitter channel assignment, Mode 1:

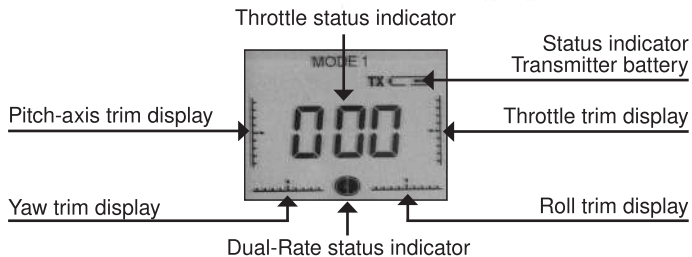
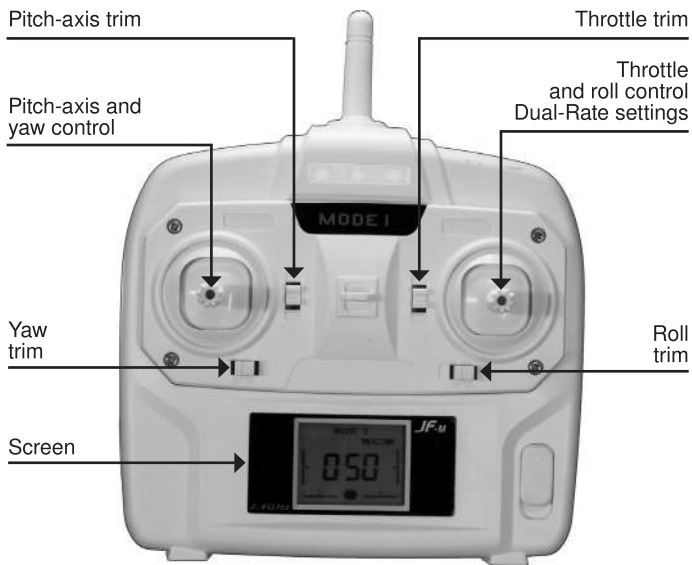

Transmitter channel assignment, Mode 2:

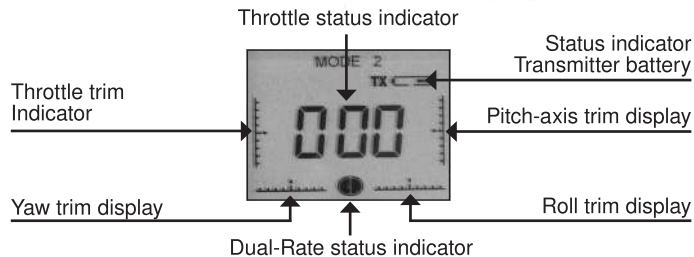
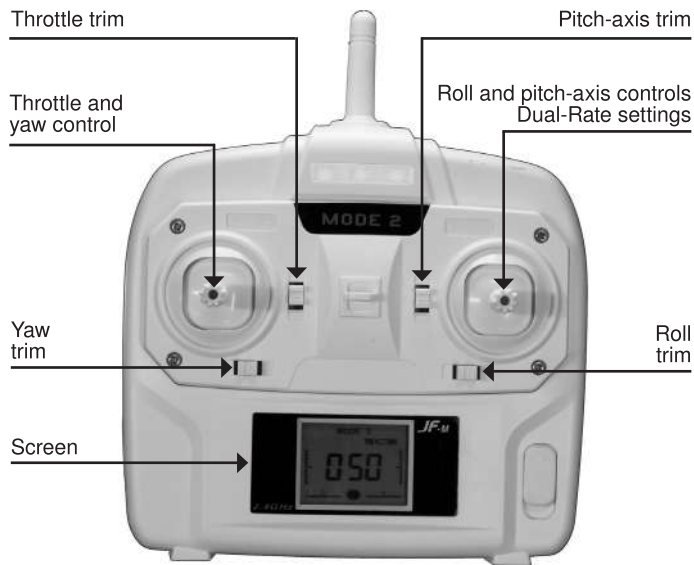

Transmitter back panel:

"AUX 2" push-switch:
Throttle mode select
switch

"AUX 1" push-switch:
Flight mode select switch



"PICTURE" push-switch:
shutter release button

"VIDEO" push-switch:
Starts and stops video recording

Overview - GALAXY VISITOR 3

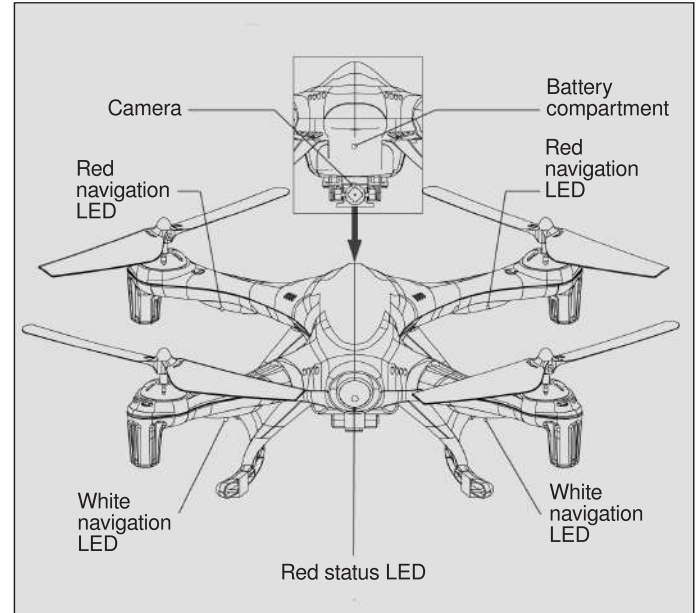

"Primary" and "expanded" control function setting

The transmitter offers the facility to adjust the sensitivity of the stick movements. Initially we recommend "softer" reduced travels for beginners.

Open the transmitter battery compartment and insert the four AA cells* (check for correct polarity).

Procedure:



Switch the transmitter on, and press the right-hand stick inward.

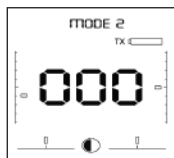

Reduced control function

The "Dual-Rate status indicator" disc on the screen is reduced to half. Manoeuvrability 50%

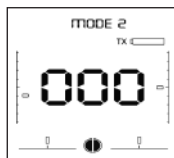

Expanded control function:

Press the right-hand stick inward again.

The full black disc now appears on the screen.

Manoeuvrability 100%

* Please read the information regarding dry cells on page 5.

Charging the flight battery



Connect the battery charger to the mains PSU, and plug the PSU into a mains socket. The red monitor LED on the charger lights up.

Connect the battery to the charger, and use "+" or "-" to set the

charge current (high = fast, low = longer battery life). Press the Start button. The monitor LED flashes. When the charge process is finished, all the LEDs on the charger flash, and you will hear an audible beep. Disconnect the battery from the charger, then disconnect the mains PSU from the wall socket.



Safety Notes

The battery must not be left unsupervised during the charge process or be placed on an inflammable surface. Protect from damp. Do not subject it to direct sunshine, and do not cover the charger.

Do not charge batteries that are hot to the touch. Allow batteries to cool down to ambient temperature. Charge the battery only using the charger included in the set; do not use any other charger. The charger should only be used to charge the battery included in the set. Not suitable for charging the transmitter battery!

It is essential to read right through the safety notes relating to LiPo batteries on page 11.



Safety Notes regarding LiPo batteries:

- Do not place the battery in water or any other liquid.
- Never heat or incinerate the pack, or place it in a microwave oven.
- Avoid short-circuits, and never charge the battery with reversed polarity.
- Do not subject the battery to pressure or shock loads, and never distort or throw the pack.
- Never solder directly to the battery.
- Do not modify or open the battery.
- Batteries must only be charged with a suitable charger; never connect the battery directly to a mains power supply.
- Never charge or discharge a battery in bright sunlight, or close to a heater or open fire.
- Do not use the battery in areas subject to high levels of static electricity.
- Never leave the battery on charge unsupervised.
- Do not charge the battery in an inflammable environment, or on an inflammable surface.
- Any of these errors can result in damage to the battery, explosion or fire.
- Keep the battery away from children.
- If electrolyte should escape, do not expose it to fire, as the material is highly inflammable and may ignite.
- Do not allow fluid electrolyte to come into contact with eyes. If this should happen, flush with copious amounts of water and contact a doctor without delay.
- The fluid electrolyte can also be removed from clothing and other objects by rinsing with copious amounts of water.

LIABILITY EXCLUSION

Since robbe Modellsport is not in a position to monitor the handling of these batteries, we expressly deny all liability and guarantee claims where the batteries have been incorrectly charged, discharged or handled.

Flight preparation

Visual checks

Before flying the model, check that there is no obvious flying damage to the case or rotors.

1. Open the transmitter battery compartment and insert the four AA dry cells (maintain correct polarity). Lay the transmitter down flat, and switch it on. Do not touch the transmitter for at least three seconds!

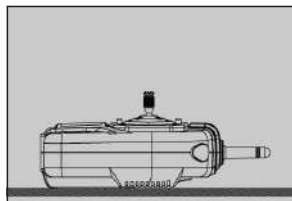

2. Place the flight battery in the Galaxy Visitor 3 and connect it. Now leave the Galaxy Visitor 3 motionless until the red status LED lights up constantly. This may take a little while.

3. At lift-off the transmitter aerial must point towards the red status LED on the Galaxy Visitor 3.

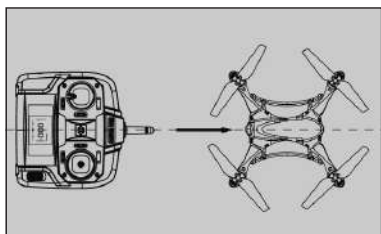

4. If you wish to fly the Galaxy Visitor 3 in intelligent control mode, the transmitter aerial must be directed at the model constantly!
5. The Galaxy Visitor 3 must not be taken off until the red status LED lights up constantly in conventional control mode, or flashes red in intelligent control mode. After every landing the Galaxy Visitor 3 carries out a brief initialisation procedure; please ensure that the status LED indicates the same mode as previously. If this is not the case, disconnect the flight battery then re-connect it so that the model can re-initialise itself.



Never take off if the red status LED is not glowing constantly or flashing!

6. If you intend to fly outdoors at a height of more than three metres using "normal" throttle and "height stabilisation" modes, there is a method of reducing the model's altitude quickly: all you have to do is press the AUX2 button once in normal mode, or twice in height stabilisation mode. This takes you to Beginner mode, and the copter automatically descends to a height of about 2 - 3 metres. After pressing the AUX2 button, we recommend that you keep a careful watch on the model's height, and adjust it with the throttle stick if necessary.
7. When the red LED starts flashing at a high rate, the battery has almost reached the end of its capacity. At this point you should land the copter as quickly as possible.

Trim settings, Mode 1

Throttle trim:

If the rotors start to spin without the throttle stick being touched, or do not respond to stick movements, you must adjust the throttle trim until they stop moving.

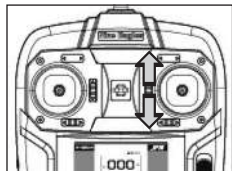

Yaw trim:

If the model's nose turns to right or left when it lifts off, adjust the yaw trim to correct the rotation until the model maintains a stable heading.

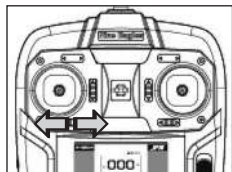

Pitch-axis trim:

If the model flies forward or back when it lifts off, adjust the pitch-axis trim until it hovers over one point.

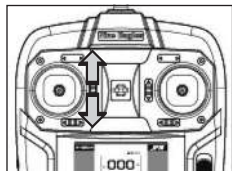

Roll trim:

If the model moves bodily to left or right when it lifts off, adjust the roll trim until the model remains in a stable hover.

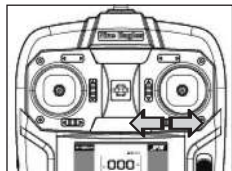

Trim settings, Mode 2

Throttle trim:

If the rotors start to spin without the throttle stick being touched, or do not respond to stick movements, you must adjust the throttle trim until they stop moving.

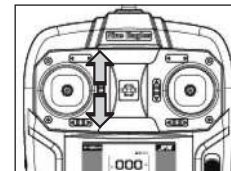

Yaw trim:

If the model's nose turns to right or left when it lifts off, adjust the yaw trim to correct the rotation until the model maintains a stable heading.

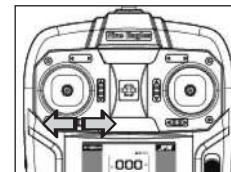

Pitch-axis trim:

If the model flies forward or back when it lifts off, adjust the pitch-axis trim until it hovers over one point.

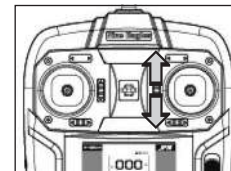

Roll trim:

If the model moves bodily to left or right when it lifts off, adjust the roll trim until the model remains in a stable hover.

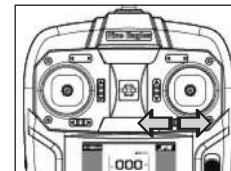

Basic information on flying the GALAXY VISITOR 3

Mode 1

Mode 2

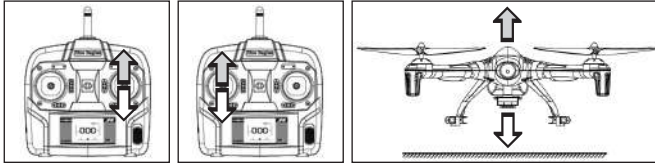

Move the throttle stick forward, and the GALAXY VISITOR 3 climbs. Pull it back, and the model descends.

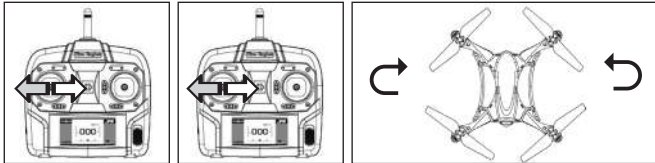

Move the yaw stick to one side, and the GALAXY VISITOR 3 rotates in the corresponding direction around the vertical axis.

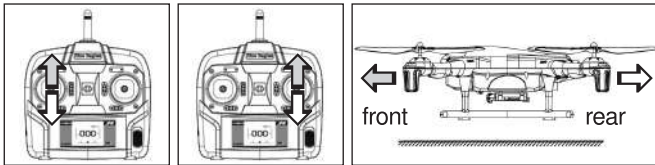

If you move the pitch-axis stick forward or back, the GALAXY VISITOR 3 flies in the corresponding direction.

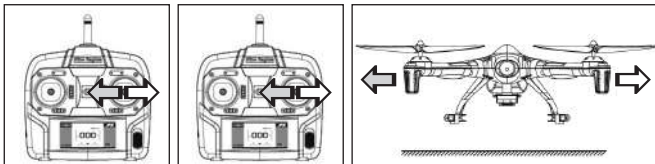

If you move the roll stick to right or left, the GALAXY VISITOR 3 moves in the corresponding direction.



CAUTION: only the third illustration shows the model facing left. All the other pictures show the model's tail facing the observer. Please note that the direction of control response changes according to the model's flight attitude. For example, the pitch-axis and roll functions are reversed when the model is flying toward the pilot.



CAUTION: since magnetic field sensors are fitted to the model as well as the transmitter, the quadcopter should not be operated in the vicinity of powerful magnetic fields, such as high-tension overhead cables or transformers. The model could crash if interference affects the magnetic sensors.

Practice flying

The flying field

The model should only ever be flown in a suitable environment such as an indoor flying hall, devoid of obstacles. If you wish to fly the quadcopter in the open air, please note that there should be no wind, and no trees, high-tension cables or other obstacles in the vicinity.

Practising with the model

Check the model and the radio control system, then switch the transmitter on, followed by the model.

Place the GALAXY VISITOR 3 on the ground about two metres in front of you, and check that its tail is facing you.

Cautiously move the throttle stick forward until the model lifts off. Allow the copter to rise briskly to a height of about 0.5 metres, and try to keep it motionless. If the model is unstable, uncontrollable or vibrates, reduce the throttle again immediately and land the GALAXY VISITOR 3.

If you are a beginner, we recommend that you keep to a height of about 0.5 metres during the first few flights. Please do not fly lower than 0.3 metres, because the model will then be in ground-effect, which is caused by the downflow of air from the rotors. This effect makes it more difficult to fly the machine smoothly. It is also important not to fly too high, as any unintended crash will then result in more serious damage.

Once you have learned the knack of taking off briskly, maintaining a given height, and landing softly, it is time to practise the roll, pitch-axis and yaw functions. During these flights keep the tail facing you at all times.

It is important to keep your model in one position at first; try to keep it in the same position and attitude as after take-off.



CAUTION: land the model immediately when the flight battery is almost flat. For example: when the GALAXY VISITOR 3 cannot climb higher than 0.5 metres. Don't fly the model again until you have given the flight battery a full charge.

Remove the flight battery from the model immediately after landing, and switch the transmitter off.

If your model crashes after colliding with an obstacle, it is essential to check for damage caused by the impact before you fly again.

Please don't leave the flight battery in the model when you are not actually flying it. Never discharge the battery completely, as deep-discharging can ruin it. If you do not intend to fly the model for a long period, it is best to remove the dry cells from the transmitter too.

Brake function

The GALAXY VISITOR 3 features an automatic brake function. If you abruptly release the roll / pitch-axis stick while the model is flying forward, its forward speed is automatically reduced. This function can be very useful in avoiding collisions with obstacles.

Signal Loss Protection function

If the radio link is interrupted while the model is in the air - e.g. the copter flies beyond the range of the radio control system, the transmitter fails, interference affects the signal, etc. - the model takes up a stable hover at a height of about 2 - 3 m for about five seconds before descending automatically to a landing.

Conventional flight mode and intelligent flight mode

Until now the direction of flight of radio-controlled models was always fixed, i.e. forward was always forward, and back was always back. The drawback to a fixed direction of flight is that the pilot has to re-think his commands when, for example, the model is flying towards him. In this case the pilot gives a command to turn right or left, but the model now moves in exactly the opposite direction relative to him. This "conventional flight mode" is very difficult to master, especially for the beginner. The situation is even worse with quadcopters, as their layout makes it even harder to detect which side of the model is forward, back, right and left. That is why we have incorporated an "intelligent control mode" in the GALAXY VISITOR 3. If the machine is operated in this control mode, forward on the model does not always equate to the forward direction of flight. This means that the model always flies towards the pilot if he moves the pitch-axis stick toward himself. It makes no difference where the actual front face of the quadcopter is pointing.

CAUTION: when you operate the copter in intelligent flight mode, the transmitter aerial should always face the model, as this flight mode works best in this situation.

Switching between the two flight modes

First switch the radio control transmitter on, then connect the receiver power supply in the GALAXY VISITOR 3. Hold the AUX 1 button pressed in for about three seconds, and do not release it until the Status LED starts flashing slowly. This method can be used at any time to switch between the two flight modes. If you are a beginner, we recommend that you set the mode on the ground, and do not change it in flight, otherwise you could lose control of the model.

Conventional flight mode

The Status LED glows constantly red when the GALAXY VISITOR 3 is operated in conventional flight mode. In this mode "forward on the model" is always "the forward flight direction".

Intelligent flight mode

The Status LED flashes slowly red when the GALAXY VISITOR 3 is operated in intelligent flight mode. In this mode "forward on the model" is always the side which faces away from the transmitter.



CAUTION: when the model takes off, the transmitter aerial must always face the Status LED. If you neglect this, you may find that the control directions are not correct.

Switching the acceleration sensor on and off

When you are confident of flying the GALAXY VISITOR 3, you may wish to switch off the acceleration sensors in order to make the model more agile. This is accomplished by moving the throttle stick fully back in mode 2, then moving the right-hand throttle stick to the bottom left corner. Hold it in this position until the Status LED goes out. Now release the stick: the acceleration sensor is switched off.

Repeat the procedure to switch the sensor on again. The only difference is that the Status LED glows constantly when the sensor is switched on.

CAUTION: in the GALAXY VISITOR 3's default condition (as supplied) the acceleration sensors are switched on.

Tip: if you are not sure whether the acceleration sensor is switched on or off, you can tell by the Status LED of the GALAXY VISITOR 3.

Meaning of and selecting the three throttle modes

1. **Beginner mode:** in this mode the model's maximum flying height is limited: even at the full-throttle position the model will fly no higher than 2 - 3 metres. If you move the throttle stick back again, the model responds by descending. This mode is intended to make it easier for the beginner to control the copter, to avoid crashes and collisions.
2. **Height stabilisation mode:** in this mode, if you quickly move the throttle stick to centre from its current position, the current throttle value is stored, and the model maintains constant height in the hover.

3. **Normal mode:** in this mode the model responds to control commands like a normal quadcopter.

The factory default setting is "beginner mode active".

To select any of the modes, simply press the AUX2 button once. The new mode is indicated by the following flashing sequences:

Switch to beginner mode: the Status LED goes out, flashes twice quickly, then glows constantly.

Switch to height stabilisation mode: the Status LED goes out, flashes twice quickly, once slowly, then glows constantly.

Switch to normal mode: the Status LED goes out, flashes twice quickly, twice slowly, then glows constantly.

Mode switching occurs in a loop in the following sequence:

Beginner mode → Height stabilisation mode → Normal mode → Beginner mode, etc.



Caution: we recommend that you only switch throttle modes while in conventional flight mode. If you carry out the switch in intelligent flight mode, the flashing Status LED makes it much more difficult to count the flashing signals which indicate the mode to which you have switched.

If you switch from normal to height stabilisation mode, the throttle value is reset. If the throttle stick is then not in the centre, the model could descend rapidly or even crash. We therefore recommend switching the throttle mode before take-off.

"Auto-Return" function

What is the Auto-Return function?

The effect of the Auto-Return function is to cause the model to return to the pilot automatically and immediately, regardless of its attitude. Simply press the AUX 1 button on the transmitter to trigger the Auto-Return function. It makes no difference which flight mode is currently selected.

When is it sensible to use this function?

This function makes sense in any situation where you can no longer clearly detect the GV 3's flight attitude. For example, if you allow the model to fly too far away. Simply press the AUX 1 button: the red Status LED flashes at a high rate, and the GV 3 immediately starts flying back to you.

Notes on using the Auto-Return function

When you are using this function, you should still use the throttle stick to maintain the model at a steady height. All the other controls must be left untouched while the Auto-Return function is in use. If you give another control command, the Auto-Return function ceases immediately.

The transmitter must continue to point at the model while the function is in use, and there should be no obstacles in the way.

If the model flies past you, turn round and point the transmitter aerial at the GALAXY VISITOR 3 again. If not, the model will simply maintain its course.

The Auto-Return function should only be used indoors in a hall of adequate size, or at a suitable flying field.

How is the Auto-Return function stopped?

Method 1:

The Auto-Return function ceases immediately if you operate any of the controls other than throttle.

Method 2:

Briefly press the AUX 1 button a second time.

Flight directions while Auto-Return is in use

The model always flies towards the transmitter aerial when the Auto-Return function is in use. Please refer to the illustration below.

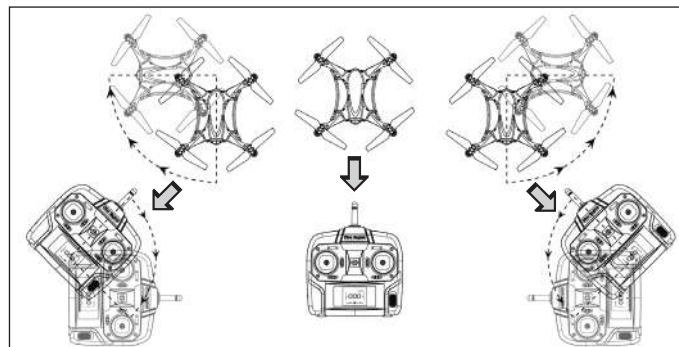

The direction of flight in Auto-Return mode changes if the position of the transmitter is altered.

Changing the direction of flight when the Auto-Return function is in use

While the model is in Auto-Return mode, you can influence its direction of flight by changing the position of the transmitter. For

example, you can fly the model in a circle around you. With the GALAXY VISITOR 3 in Auto Return mode, simply point the transmitter aerial at the copter and turn round. Since the model always tries to fly towards the aerial, the result is a circular flight path. You can also cause the model to turn left or right: simply turn the transmitter in the opposite direction to the desired turn. For example, if you wish the GALAXY VISITOR 3 to move to the right, turn the transmitter (and therefore its aerial) to the left, and vice versa.

NOTE: the Auto-Return function is available both in conventional and intelligent flight mode.

Binding the transmitter and receiver



Switch the transmitter on, set the throttle stick to the bottom position (Idle), and place it about 30 cm from the model.

Switch the copter on by connecting the flight battery, and leave it motionless. The red LED now flashes to indicate that the model is in Bind mode. The binding procedure is successful if the red LED glows constantly.

Binding is only necessary if you replace one of the radio control system components.



CAUTION: during the take-off procedure the transmitter aerial must point towards the model's red LED. If you ignore this, you may encounter problems in flight when the intelligent flight mode or the Auto-Return function is selected.

Calibrating the acceleration sensor

The acceleration sensor can be adjusted at the model's receiver. Normally the machine is calibrated correctly at the factory, and is immediately ready to fly. If you notice inconsistencies in the model's behaviour in flight, you can re-calibrate the acceleration sensor and thereby improve its flying characteristics.

Entering calibration mode

First switch the transmitter on, then place the model in a horizontal position and connect the flight battery. Hold the right-hand transmitter stick pressed in, then press the left-hand stick three times in sequence. You will hear a beep which indicates that you are in Calibration mode. Release the right-hand stick again.



Calibration

Move the throttle trim on the transmitter upward. The Status LED now flashes slowly, and the acceleration sensor is in calibration mode. Now switch the transmitter off and immediately on again. The procedure is complete when the Status LED glows constantly.



Note:

If calibration mode does not immediately start correctly, repeat the procedure until the Status LED flashes. Please be careful not to hold the right-hand stick pressed in for too long, otherwise you will enter Dual Rate set-up mode.

Dual-Rate function

The Dual-Rate function determines the GV 3's response to the pilot's control inputs. Briefly pressing in the right-hand stick selects one of the two points. The selected Dual Rate is indicated by the disc at bottom centre of the screen (see "Transmitter stick mode" on page 8). A solid disc at this point indicates the higher value; a half-disc indicates the lower value. If you are a beginner, we recommend the lower value.

Adjusting the Dual-Rate values

It is possible to adjust the two Dual-Rate values individually at the transmitter. This is accomplished by switching the transmitter on with the throttle stick at Idle, and moving the right-hand stick down until the continuous beep switches to an intermittent one. Please hold the right-hand stick in the stated position the whole time. When you hear the intermittent beep, you can set a value within the range 0 to 100 using the left-hand stick. The higher the value, the more responsive the GV 3 to the pilot's control commands. The value set always corresponds to the state of the disc on the screen. This means: if the screen shows a half-disc, you are adjusting the lower Dual-Rate value (recommended value: 40); if you see a full disc, then you are adjusting the higher value (recommended value: 100). Once you have set your preferred value, release the right-hand stick, and the set value is stored. Repeat the procedure to adjust the second value.

Note:

Please do not move the left-hand stick forward until you hear the intermittent beep, otherwise the GV 3's motors will start to run. Do not set the values too low, otherwise you may no longer be able to control the GV 3.

Speed of the Auto-Return function

It is not essential to set up this function. However, if you do wish to adjust the Auto-Return function, this is the procedure: Switch the transmitter on, and ensure that the yaw trim (below the left-hand stick) is at centre. The throttle stick must be at the Idle position. Press and hold the right-hand stick, and briefly press the left-hand stick three times. Now move the yaw trim (below the throttle stick) to the left to increase the speed at which the GV 3 carries out the Auto-Return function. The higher the speed, the faster the red Status LED on the GV 3 flashes. To reduce the Auto-Return speed, move the yaw trim to the right, and the red Status LED flashes more slowly accordingly. We recommend a high setting for outdoor flying, and a low setting for indoors.

Note:

If this mode does not start immediately, repeat the procedure until the Status LED flashes. Please note that the right-hand stick must not be held pressed in too long, otherwise you will enter set-up mode for the Dual-Rate values, and set the values to 0.

The transmitter's magnet sensor

The GV 3's transmitter includes a magnet sensor which is responsible for the correct operation of the Auto-Return function and the intelligent flight mode.

This sensor has no need to be calibrated!

You can find additional information and tips on adjustment facilities on the Product Page for the model at www.robbe.com.

Camera

Using the still photo and video function

1. Insert the SD card in the camera.
2. Switch the transmitter on, and connect the flight battery to the model.
3. The camera takes a picture when you press the "Picture" switch on the transmitter.
4. Video recording starts when you press the "Video" switch; the red LED on the camera starts flashing. Pressing "Video" again stops the recording, and the LED glows constantly.
5. If you wish to remove the SD card, please check that the video recording has stopped, and disconnect the battery from the model.

Programming the still photo / video function to a different transmitter

If you wish to use a different transmitter, set up the new model in a memory using the "Acro" template, i.e. without any mixers at all. The transmitter must possess at least five channels. The first step in programming is to determine the video switch; after that the still photo switch.

Programming procedure (Mode 2 / throttle stick left)

Enter programming mode:

1. Connect the battery to the model.
2. Switch your transmitter on.
3. Move the throttle stick fully back (towards you).
4. Move the right-hand stick fully to the right.

5. Check that the model is successfully bound to the transmitter (the red Status LED glows constantly).
6. Now wait a further two seconds before releasing the right-hand stick. The GV 3 is now in programming mode.

Programming

1. Selecting the video switch: you can use a rotary knob, a two-position switch or a three-position switch for the function. If you wish to use a rotary knob, rotate it from one end-point to the other and back three times. If you wish to use a two-position switch, move it from one end-point to the other and back three times. If you wish to use a three-position switch, move it between two positions and back three times.
2. Selecting the still photo switch: identical procedure to selecting the video switch.

For the procedures described above, the end-point of the rotary knob or switch is the base setting, which is stored. This means that the function is activated when the transmitter control is moved away from the base setting.

Quitting programming mode

Once you have adjusted the switches, move the right-hand stick fully to the left to leave programming mode.

After repairs

Checking the direction of motor rotation

If you have to carry out repairs to the model, it is essential to check the direction of rotation of all the motors (see illustration).

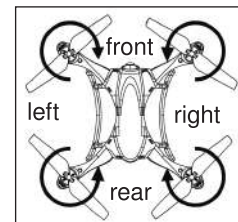

Motor sockets on the circuit board

Motor lead "A" = Socket "A" on the circuit board.
 Motor lead "B" = Socket "B" on the circuit board.
 Motor lead "C" = Socket "C" on the circuit board.
 Motor lead "D" = Socket "D" on the circuit board.

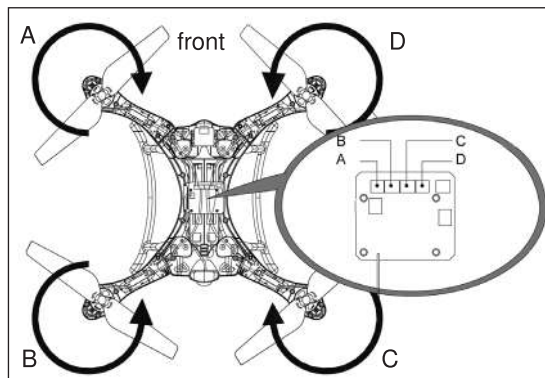

CAUTION: check that the motor leads are correctly connected after carrying out repairs.

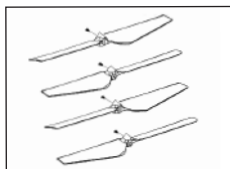

NE252901

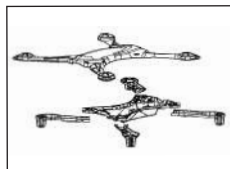

NE252902

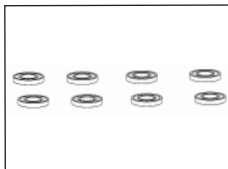

NE252903

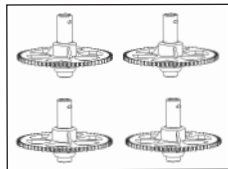

NE252904

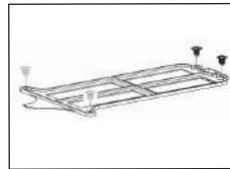

NE252905

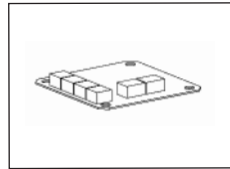

NE252906

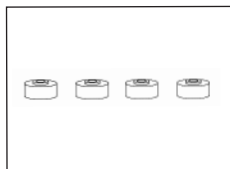

NE252907

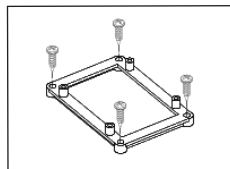

NE252908

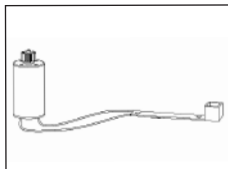

NE252909

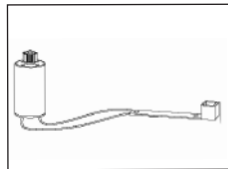

NE252910

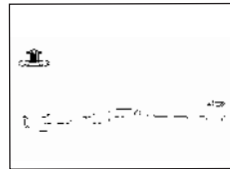

NE252911

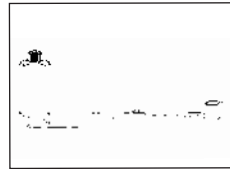

NE252912

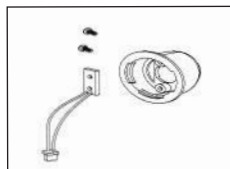

NE252913

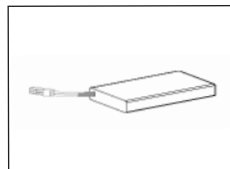

NE252914

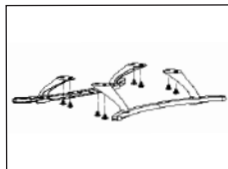

NE252915

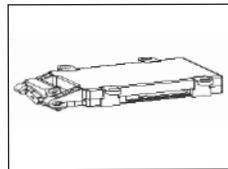

NE252916

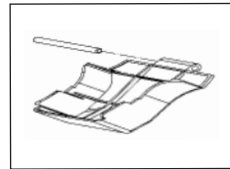

NE252917

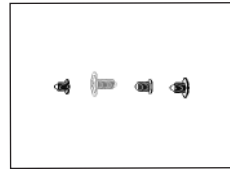

NE252918

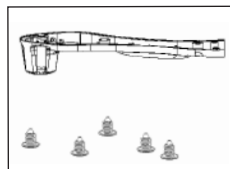

NE252919

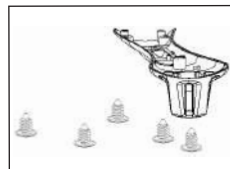

NE252920

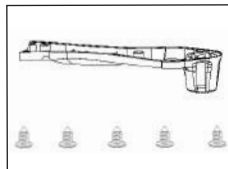

NE252921

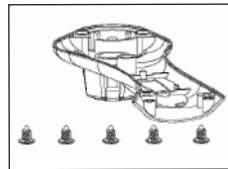

NE252922

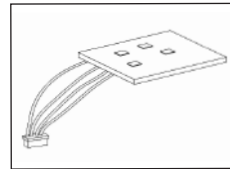

NE252923

Replacement Parts list GALAXY VISITOR 3 RTF FTR 2.4 GHz

Order No.	Description
NE252901	Main rotor blades, pack of 4
NE252902	Case, black / white
NE252903	Ballrace set, pack of 8
NE252904	Main gearwheel and shaft, pack of 4
NE252905	Battery holder
NE252906	FTR receiver
NE252907	Receiver shock absorber
NE252908	Receiver mount
NE252909	Motor front left
NE252910	Motor rear left
NE252911	Motor rear right
NE252912	Motor front right
NE252913	Status LED cover
NE252914	LiPo battery, 3.7 V / 1200 mAh, 30C
NE252915	Landing gear
NE252916	HD camera
NE252917	Case cover, battery compartment
NE252918	Screw set
NE252919	Motor mount, front right
NE252920	Motor mount, front left
NE252921	Motor mount, rear left
NE252922	Motor mount, rear right
NE252923	Altimeter
NE252513	SD / USB card reader (not shown)
NE252514	SD card, 2 GB (not shown)
NE250230	Battery charger and mains PSU (not shown)

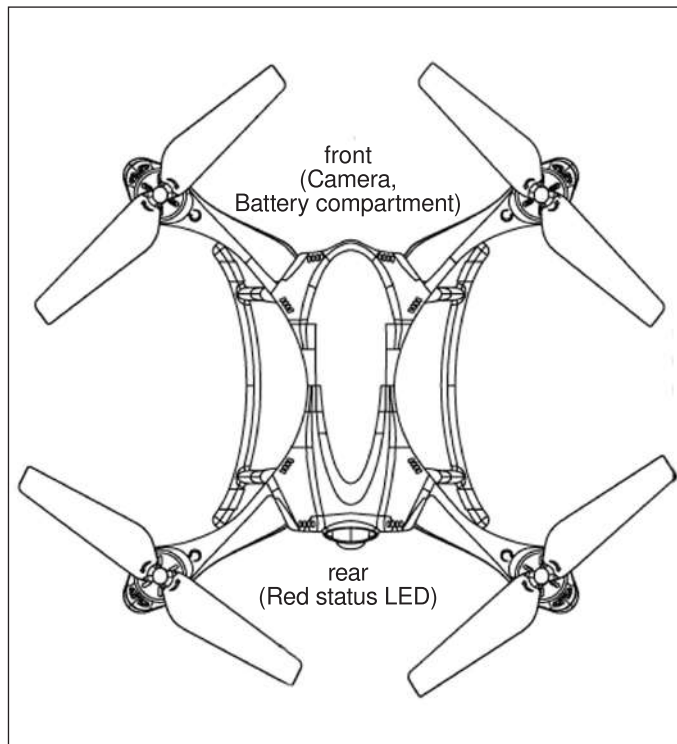

When replacing components it is very important to use the correct tool and to tighten the screws with great care.

Do not use thread-lock fluid!



robbe Modellsport GmbH & Co.KG hereby declares that this device fulfils the fundamental requirements and other relevant regulations of the appropriate CE directives. The original Conformity Declaration can be found on the Internet at www.robbe.com. Please select the specific device description, then move to "Downloads" and select "Conformity Declaration".



This symbol means that you should dispose of electrical and electronic equipment separately from the household waste when it reaches the end of its useful life. Take your unwanted equipment to your local council collection point or recycling centre. This requirement applies to member countries of the European Union as well as other non-European countries with a separate waste collection system.



Disposal of batteries

Batteries must not be discarded as domestic refuse. To protect the environment, always discharge exhausted or defective cells and take them to your local collection point; these are all retail outlets for dry and rechargeable batteries, and local recycling centres. Cover any bare wires with insulating tape in order to avoid short-circuits.

robbe Modellsport GmbH & Co.KG

Metzloserstraße 38 · D-36355 Grebenhain

Technical hotline: +49 (0)66 44 / 87-777 · hotline@robbe.com

Commercial register: Gießen Regional Court HRA 2722

Partner with personal liability:

robbe Modellsport Beteiligungs GmbH Gießen / HRB 5793 · Managing Director: Philip Janssen

Errors and technical modifications reserved · Copyright robbe Modellsport 2014

Duplication and copying of the text, in whole or in part, is only permitted with the prior written approval of robbe Modellsport GmbH & Co. KG