

HOBBY

QUADCOPTER

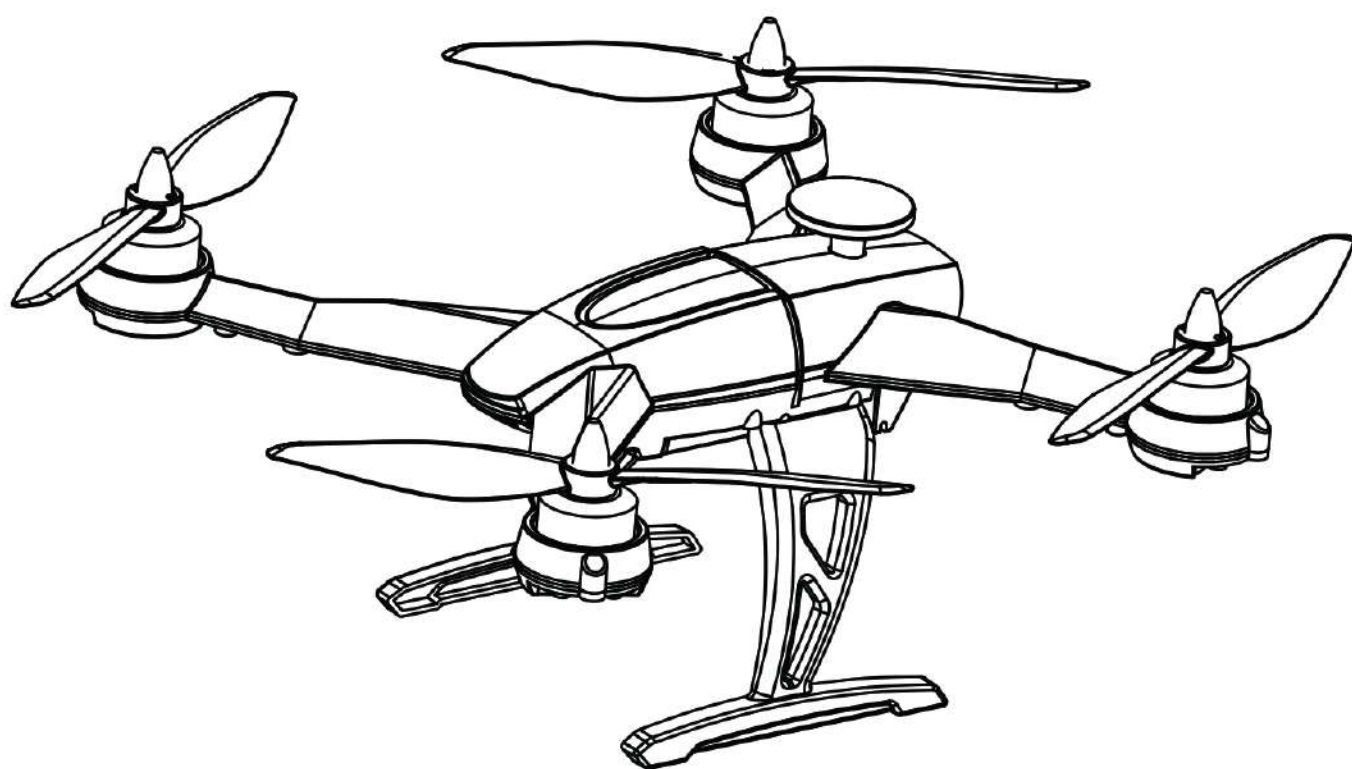

Instruction Manual
产品使用手册

X1

NOTICE

All instructions, warranties and other collateral documents are subject to change at the sole discretion of YifeiModel LLC. For up-to-date product literature.

Meaning of Special Language

The following terms are used throughout the product literature to indicate various levels of potential harm when operating this product:

NOTICE: Procedures, which if not properly followed, create a possibility of physical property damage AND a little or no possibility of injury.

CAUTION: Procedures, which if not properly followed, create the possibility of physical property damage AND a possibility of serious injury.

WARNING: Procedures, which if not properly followed, create the possibility of physical property collateral damage, and serious injury OR create a high probability of superficial injury.



WARNING: Read the ENTIRE instruction manual to become familiar with the features of the product before operating. Failure to operate the product correctly can result in damage to the product, personal property and cause serious injury.

This is a sophisticated hobby product. It must be operated with caution and common sense and requires some basic mechanical ability. Failure to operate this product in a safe and responsible manner could result in injury or damage to the product or other property. This product is not intended for use by children without direct adult supervision. This manual contains instructions for safety, operation and maintenance. It is essential to read and follow all the instructions and warnings in the manual, prior to assembly, setup or use, in order to operate correctly and avoid damage or serious injury.

Age Recommendation: Not for children under 14 years. This is not a toy

Safety Precautions and Warnings

- Always keep a safe distance in all directions around your model to avoid collisions or injury. This model is controlled by a radio signal subject to interference from many sources outside your control. Interference can cause momentary loss of control.
- Always operate your model in open spaces away from full-size vehicles, traffic and people.
- Always carefully follow the directions and warnings for this and any optional support equipment (chargers, rechargeable battery packs, etc.).
- Always keep all chemicals, small parts and anything electrical out of the reach of children.
- Always avoid water exposure to all equipment not specifically designed and protected for this purpose. Moisture causes damage to electronics.
- Never place any portion of the model in your mouth as it could cause serious injury or even death.
- Never operate your model with low transmitter batteries.
- Always keep aircraft in sight and under control.
- Always move the throttle fully down at rotor strike.
- Always use fully charged batteries.
- Always keep transmitter powered on while aircraft is powered,
- Always remove batteries before disassembly.
- Always keep moving parts clean.
- Always keep parts dry,
- Always let parts cool after use before touching.
- Always remove batteries after use,
- Never operate aircraft with damaged wiring,
- Never touch moving parts

X1 *QUADCOPTER*

Box Contents

- Airframe X1
- Transmitter 6 Channel 2.4Ghz
- Battery 2S 7.4V 20C 1200mAh Li-Po
- Charger 2S Li-Po DC Charger with AC Power Supply
- Propeller Forward and Reversal
- Tripod
- Protector
- Instruction manual
- propeller nut wrench
- Screwdriver

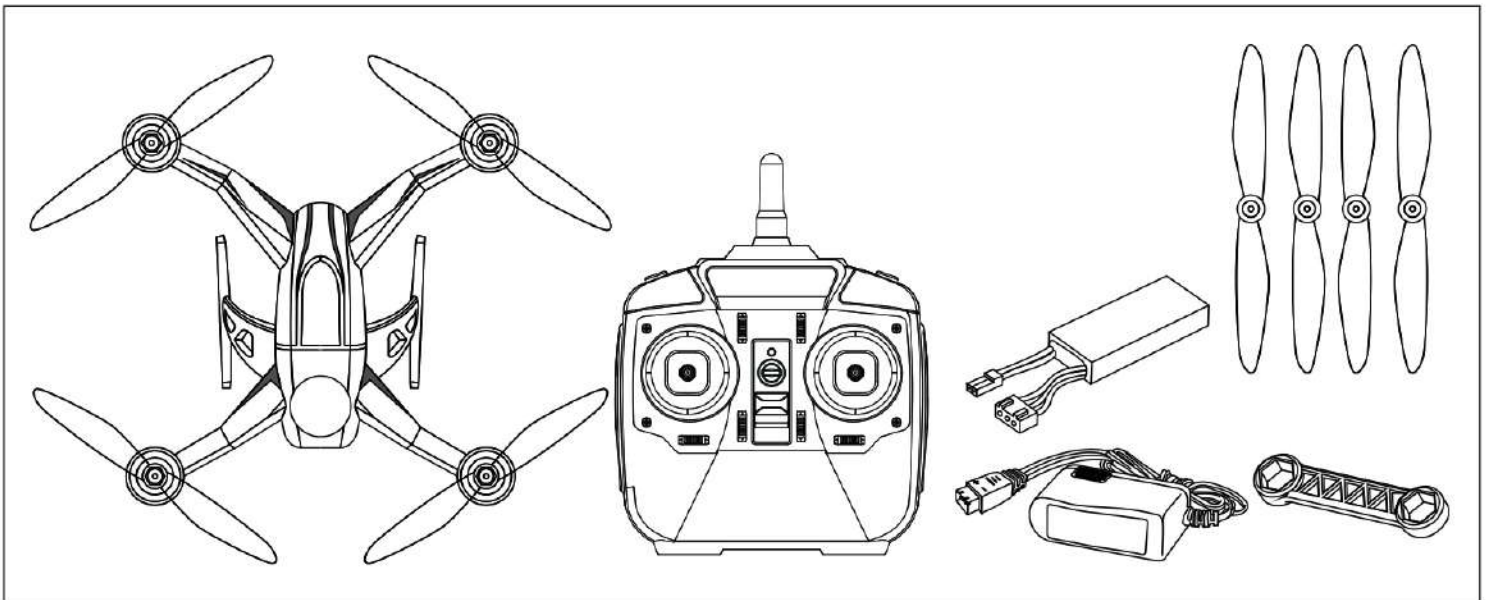

Remote control function

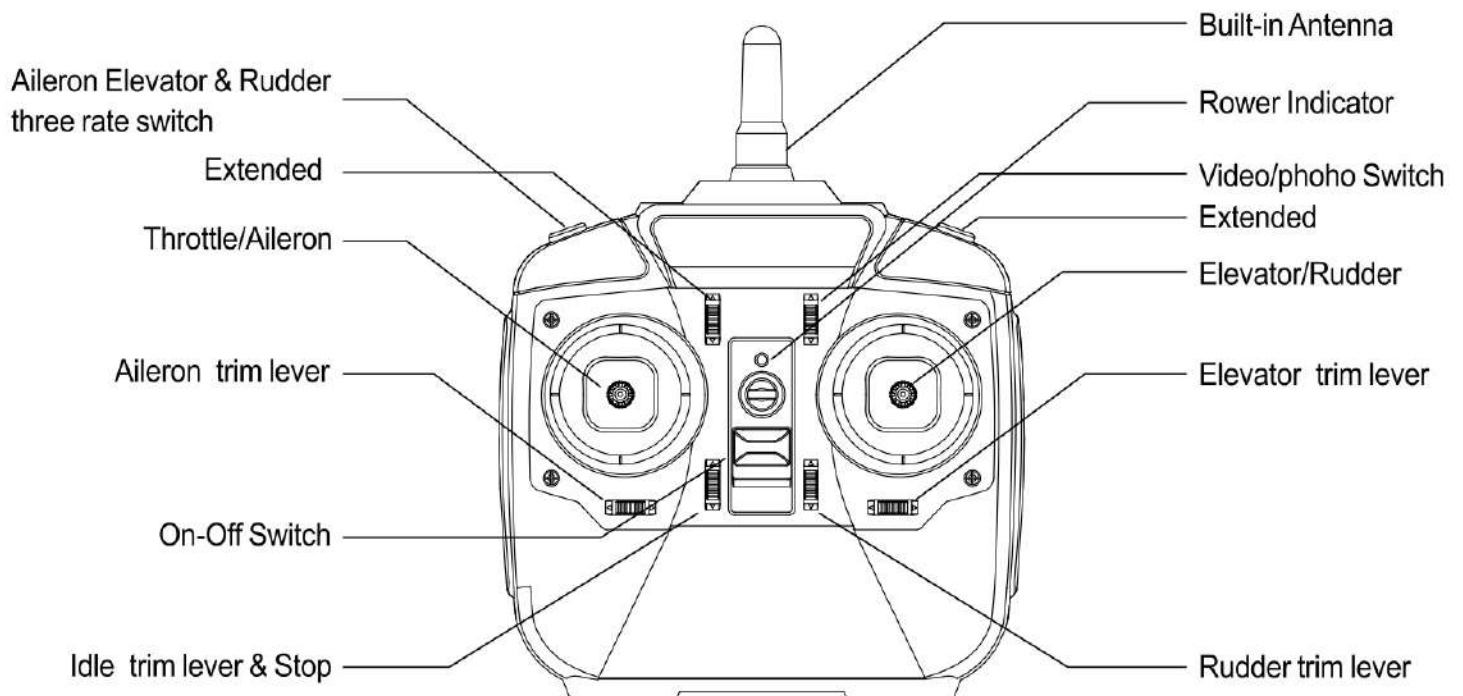

First Flight Preparation

- Remove and inspect contents
- Begin charging the flight battery
- Install the flight battery in the quadcopter (once it has been fully charged)
- Program your computer transmitter
- Bind your transmitter
- Familiarize suitable area for flying

Charging Warnings

The Battery Charger included with your quadcopter has been designed to safely charge the Li-Po battery.

CAUTION: All instructions and warnings must be followed exactly. Mishandling of Li-Po batteries can result in a fire, personal injury and/or property damage.

- By handling, charging or using the included Li-Po battery, you assume all risks associated with lithium batteries.
- If at any time the battery begins to balloon or swell, discontinue use immediately. If charging or discharging, discontinue and disconnect. Continuing to use, charge or discharge a battery that is ballooning or swelling can result in fire.
- Always store the battery at room temperature in a dry area for best results.
- Always transport or temporarily store the battery in a temperature range of 40-120F (5-49C). Do not store battery or model in a car be damaged or even catch fire.
- Always charge batteries away from flammable materials.

- Always inspect the battery before charging
- Always disconnect the battery after charging, and let the charger cool between charges.
- Always constantly monitor the temperature of the battery pack while charging.
ONLY USE A CHARGER SPECIFICALLY DESIGNED TO CHARGE LI-PO BATTERIES. Failure to charge the battery with a compatible charger may cause a fire resulting in personal injury and/or property damage.
- Never discharge Li-Po cells to below 3V under load.
- Never cover warning labels with hook and loop strips.
- Never leave charging batteries unattended.
- Never charge batteries outside recommended levels.
- Never charge damaged batteries.
- Never attempt to dismantle or alter the charger.
- Never allow minors to charge battery packs.
- Never charge batteries in extremely hot or cold places (recommended between 40-120F or 5-49C) or place in direct sunlight

Battery Charging

NOTICE: Charge only batteries that are cool to the touch and are not damaged. Look at the battery to make sure it is not damaged.

1. Connect the AC power supply to the battery balance lead.
2. Connect the battery to the balance lead charger adapter
3. Battery charging is complete when the charger LED is solid green
4. Always disconnect the flight battery from the charger immediately upon completion of charging.

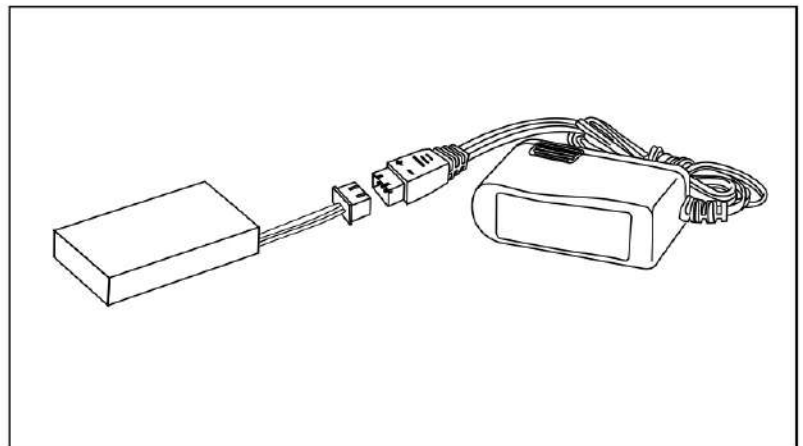

Charging a fully discharged (not over-discharged) 1200mAh battery takes approximately 90 minutes.



CAUTION: Only use chargers specifically designed to charge the included Li-Po battery. Failure to do so could result in fire, causing injury or property damage.



CAUTION: Never exceed the recommended charge rate.

LED Indications for the charger

Green LED with power connected but without battery: Standby

Red LED: Battery connected

Solid Green LED: Full charge



CAUTION: Once charging is complete, immediately remove the battery. Never leave a battery connected to the charger.

Installing the Flight Battery

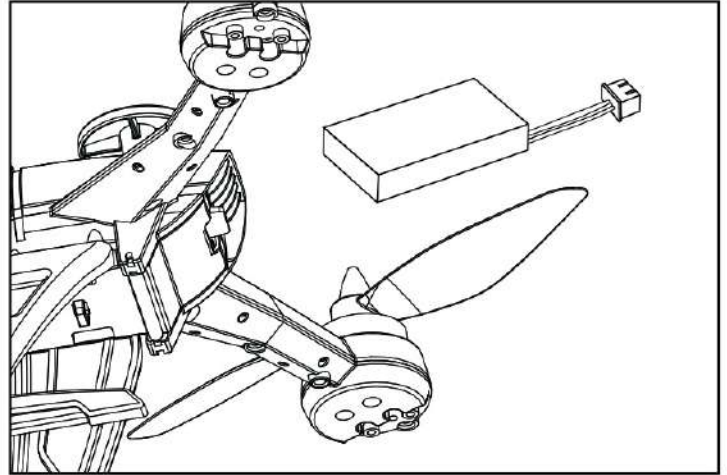
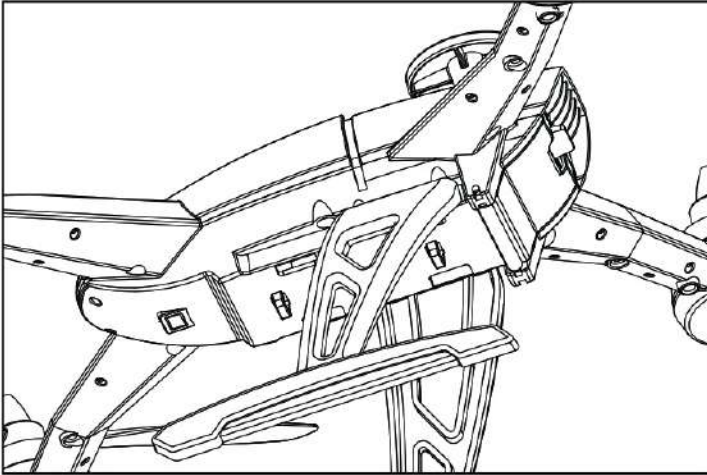

1. Remove the battery cover and install the battery in the quadcopter
2. Connect the battery cable to the control unit [hear the notes (re, MI, do)] and replace the battery cover.
3. Place the quadcopter on its landing gear on a flat surface.



CAUTION: Always disconnect the Li-Po battery from the aircraft when not flying to avoid over-discharging the battery. Batteries discharged to a voltage lower than the lowest approved voltage may become damaged, resulting in loss of performance and potential fire when batteries are charged.

Flight Mode and Rate Selection

- **Mode one:** default
steering and rudder are 10% it is slow speed mode
- **Mode two:** comfortable flight
steering and rudder are 25% it is middle speed mode
- **Mode three:** fast flight
steering and rudder are 45% it is fast speed mode



CAUTION: Fast speed mode is not suitable for beginners

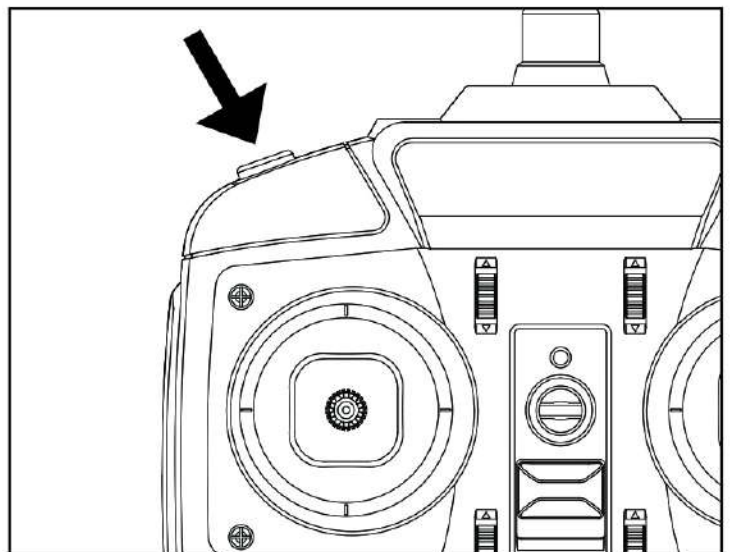

Understanding the Primary Flight Controls

if you are not familiar with the controls of your X1, take a few minutes to familiarize yourself with them before attempting your first flight.

Throttle

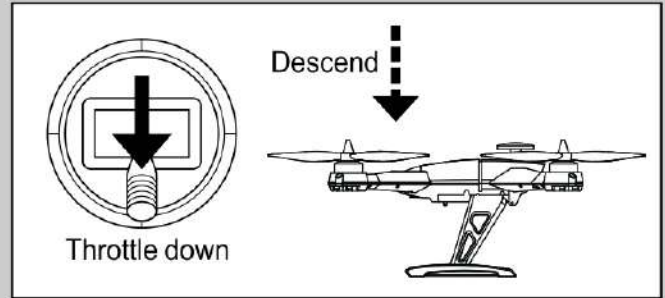
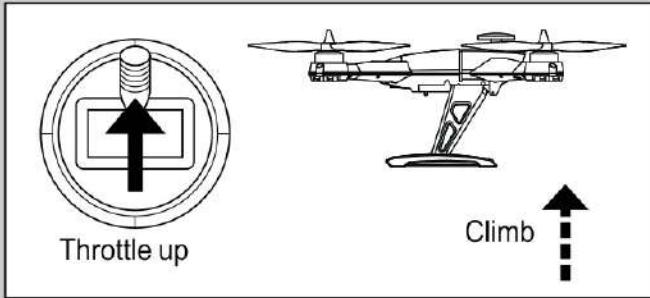

Rudder

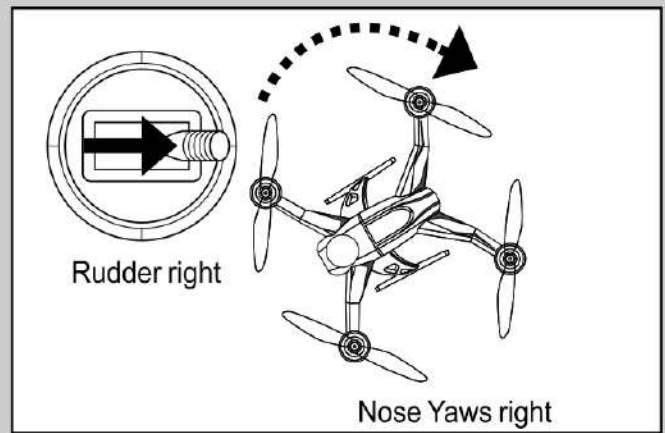
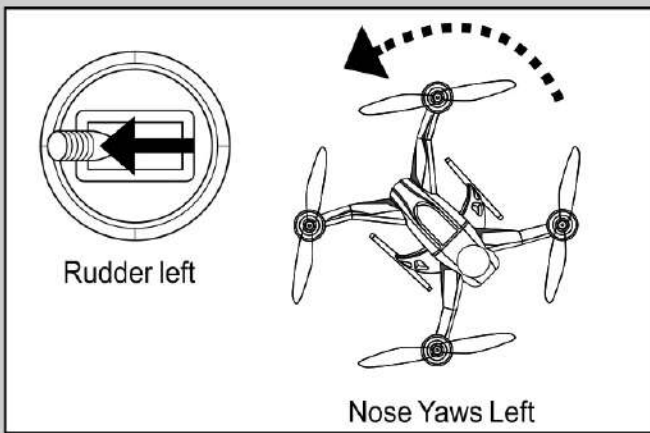

Elevator

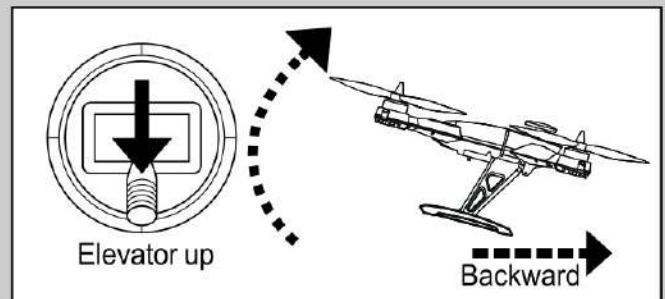
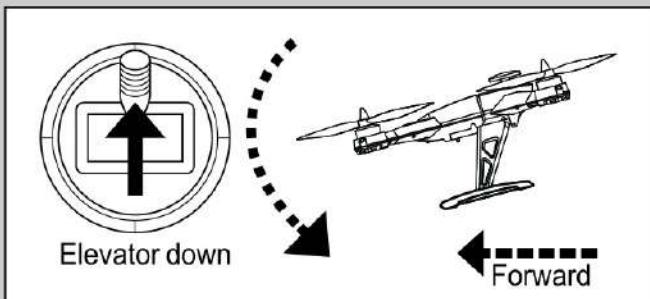

Elevator

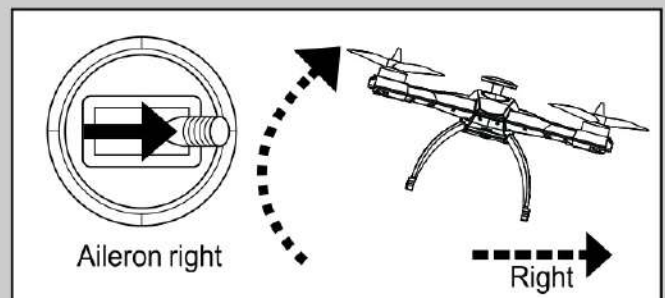
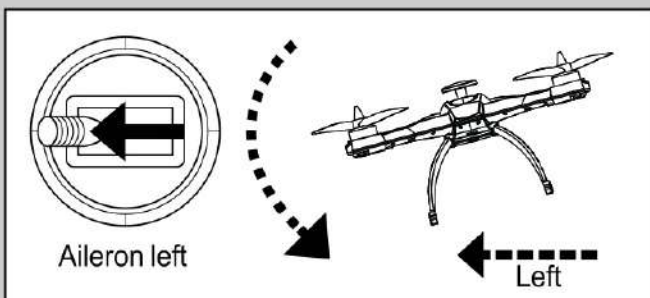

Flying the X1

Takeoff

1. When you are prepared to fly, put the airplane horizontally on the floor, switch on power.
2. Then you can hear three voices and LED lights on the airplane are flashing.
3. Close the battery cover.
4. Open the transmitter power.
5. You can hear DIDI voice LED lights on the airplane are flashing rapidly meanwhile four pieces motors make didi voice and LED lights turn on which means matching code is finished.

Unlock the transmitter

When you hear DIDI voice which means unlock is finished



CAUTION: After unlock is finished, the airplane will be automatically locked if you do not start idling. It needs unlock again to fly.

Start idling

Do not move direction stick, pull the throttle stick to the lowest, turn right then turn left finally turn right, you can hear DIDI voice from controller, 4 pcs blades begin to rotate slowly which means the airplane is on idling and ready for fly.

Stop Flying

Land the airplane on the ground, throttle is in lowest and idling stage, do not move throttle about 10 seconds, the airplane will automatically stop and locked. Or on the idling stage pull the idling button to the lowest and press again to stop.

Typical flight times for the included battery range from 13 to 15 minutes

Idle setting

Idling five grades default setting is 3 idling button up increasing two grades, down decreasing two grades.

- 1 idling is slowest naturally falling speed is fastest throttle maximum 80%
- 2 idling is a little slow naturally falling speed is faster throttle maximum 85%
- 3 idling is medium naturally falling speed is middle throttle maximum 90%
- 4 idling is fast naturally falling speed is slower throttle maximum 95%
- 4 idling is fastest naturally falling speed is very slow throttle maximum 100%

Low Voltage Cutoff [LVC]

LVC decreases the power to the motors when the battery voltage gets low. when the motor power decreases and the LED blink, land the aircraft immediately and recharge the flight battery. LVC does not prevent the bat from over-discharge during storage.

NOTICE: repeated flying to LVC will damage the battery.

Unlock Signal

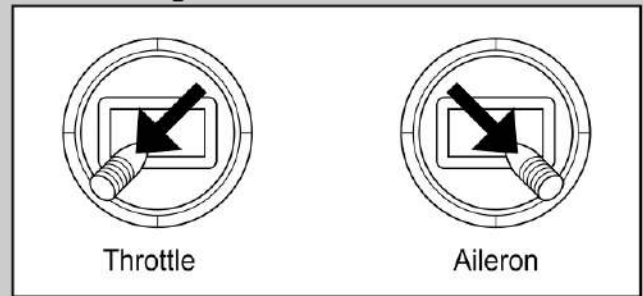

Start Idling Signal

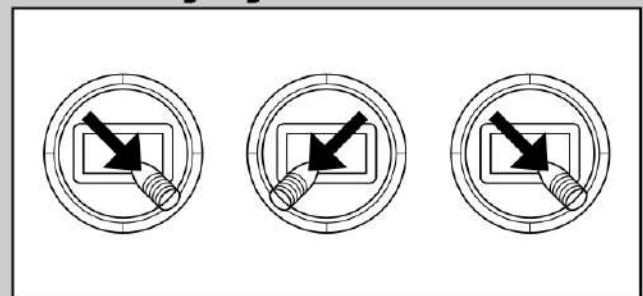

水平校准手势

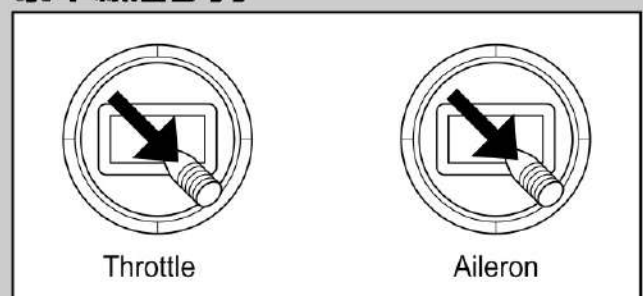

To land, slowly decrease the throttle while in a low-level hover. after Idle, disconnect and remove the battery from the aircraft after use to prevent trickle discharge. fully charge your battery before storing it. during storage, make sure the battery charge does not fall below 3.6V per cell.

Post-Flight Inspection and Maintenance

Cleaning

Make sure the battery is not connected before cleaning. remove dust and debris with a soft brush or adry, lint-free cloth.

Motors

Replace the moter when the model will not fly steady or veers off when doing a climb out.

Wiring

Make sure the wiring does not block moving parts. replace damaged wiring and loose connectors.

Fasteners

Make sure there are no loose screws,other fasteners or connectors.Do not over-tighten metal screw in plastic parts. Tighten screws so the parts are mated together,then turn the screw only 1/8th of a turn more.

Propellers

Make sure there is no damage to the propellers or other parts that ove at high speed.Damage to these parts includes cracks,burrs,chips or scratches.Replace damaged parts before flying.

Removing the Propellers

remove the propeller nuts using the included propeller nut wrench according to the illustration.Install them in the opposite direction.

Instructions for disposal of WEEE by users in the European Union



This product must not be disposed of with other waste.instead,it is the user's responsibility to dispose of their waste equipment. by handing it over to a designated collections point for the recycling of waste electrical and electronic equipment.the separate collection and recycling of your waste equipment at the time of disposal will help to conserve natural resources and make sure that it is recycled in a manner that protects human health and the environment.For more information about where you can drop off your waste equipment for recyclig, please contact your local city office,your household waste disposal service or where you purchased the product.

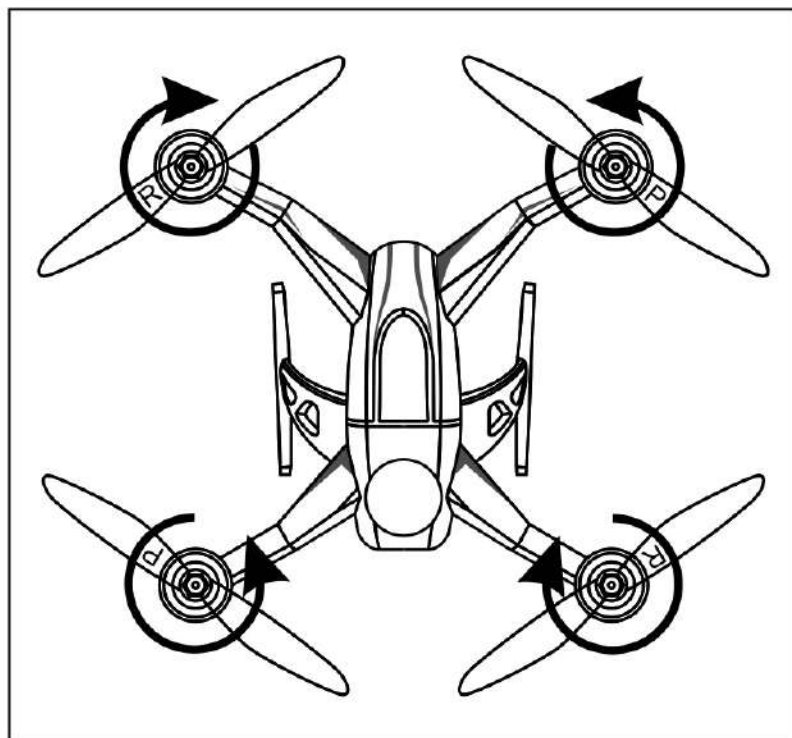

Automatic safety warning and operation

Blades safety protection

When aircraft meets obstacles,it will start protection programme. Blades will try to rotate ceaselessly to protect circuit board. When the aircraft crashes obstacle,it will stop flying automatically.The level must be re calibrated before starting the flight.

Low voltage alert

The aircraft will alert when the duration of flight is 90% LED lights flash. The throttle will automatically slow down after 1-2seconds and the aircraft will descend. Please make sure the aircraft under your control and within your sight in order to prevent damage from dropping down.

Remote controller Low Voltage alert

When the batteries in the controller are lower than 4.5v,LED lights on the controller will flash and make DIDI alarm to remind user changing batteries for normal flight.The level must be re calibrated before starting the flight.