

**Ruko**<sup>®</sup>

**14+**  
for age

# User Manual

v2.0

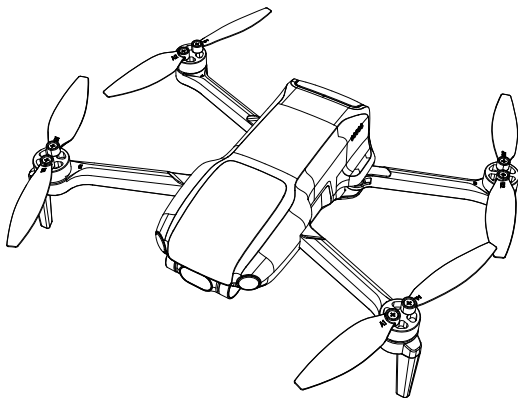

## U11MINI 4K

CONTACT US FOR MORE TECH SUPPORT

 +1 (888)892-0155 | Mon-Fri 7:00AM - 7:00PM (PST)



rukotoy.com

CONTACT US FOR MORE TECH SUPPORT



+1 (888)892-0155

Mon-Fri 7:00AM - 7:00PM (PST)



+1 (732) 207-0697



# Content

<b>1. Product List</b>	1
<b>2. Requirements of Flight Environment</b>	2
<b>3. Find Drone</b>	3
<b>4. Routine Maintenance and Transportation</b>	4
<b>5. Flight Operation Guidelines</b>	6
<b>6. FCC Safety and Disclaimer</b>	8
<b>7. Disclaimer and Warning</b>	9
<b>1 Using This Manual</b>	10
1.1 Legend	10
1.2 Recommendations	10
1.3 Download Ruko U11 App	10
1.4 Video Tutorials	11
<b>2 Product Profile</b>	11
2.1 Introduction	11
2.2 Feature Highlights	11
2.3 Preparing the Aircraft	12
2.4 Aircraft Diagram	13
<b>3 Aircraft</b>	15
3.1 Flight Speed Mode	15
3.2 Calibration and Aircraft Status Indicator	15
3.3 Return to Home	17
3.4 Optical Flow Positioning/TOF (Indoor Attitude Mode)	25

3.5 Intelligent Flight Mode	26
3.6 Propeller	32
3.7 Intelligent Flight Battery	33
3.8 Camera Overview	37
<b>4 Remote Controller</b>	<b>39</b>
4.1 Remote Controller Profile	39
4.2 Using the Remote Controller	40
4.3 Communication Range of Remote Controller	43
4.4 Matching the Remote Controller	44
<b>5 Ruko U11 App</b>	<b>46</b>
5.1 Home	46
5.2 Control Interface	47
<b>6 Flight</b>	<b>52</b>
6.1 Flight Environment Requirements	52
6.2 Connection&Settings	53
6.3 Calibration before Flight	55
6.4 Starting/Stopping the Motors	58
6.5 Auto Takeoff/Landing	59
6.6 Basic Flight Steps	61
<b>7 Appendix</b>	<b>62</b>
7.1 Specification Parameter	62
7.2 Accessories	63
7.3 Common Problems and Solutions	64

## 1.Product List



Drone



Remote Controller



Intelligent Flight Battery



Camera Cover



Spare Propeller



USB Charging Cable



Screwdriver



Screw



Joystick



Micro USB connector



USB-C connector



Lightning connector



Quick Start Guide

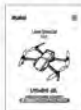

User Manual

## 2.Requirements of Flight Environment

### • Flight Safety.



Sunny



Windless

Strong GPS  
SignalMaintain Line  
of SightFly Below  
390ft

- It is recommended to fly in an open space with a radius of at least 33 feet and no obstacles. High-voltage power lines and communication towers can interfere with control signals; avoid flying near these areas.
- Do not fly over or near crowds. Avoid flying in extreme weather conditions such as high or low temperatures, or during thunderstorms and heavy rain.



Obstacles

Voltage power  
lines

Crowds



High temperature



Low temperature



Lightning



Snow



Rain



Fog



Windy



### 3.Find Drone

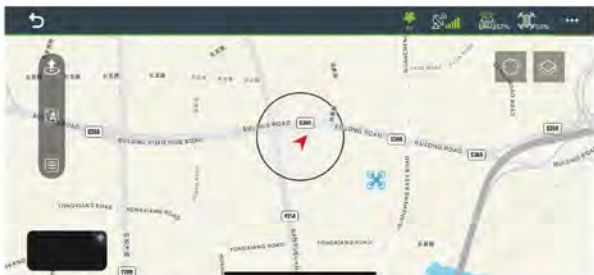
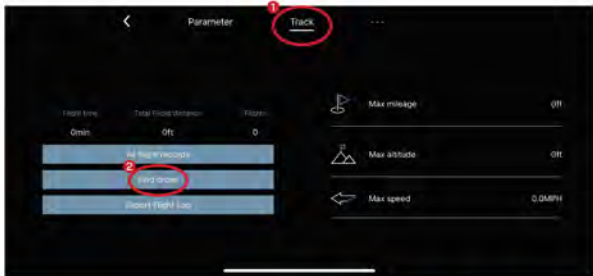

- You can tap "Track" and then "Find drone" in the App settings to view the location of the last time your phone connected to the drone.
- Note: The phone needs to be connected to the Internet to cache map data.

	My Location		Drone Location
	Tap to switch between		
	and 		Tap to switch three layers of map

## 4. Routine Maintenance and Transportation

- Please fully charge the battery for the first time before using it.
- It is recommended to charge and discharge it once a month, do not store it fully charged, keep 50%-60% of the charge, the storage temperature is 10-40°C, and the best storage temperature is 19-21°C.
- Water enters the battery and the battery protection board fails, which will cause the battery not to be used normally. Do not use the battery in rain or in a humid environment, as this may cause the battery to self-ignite or even explode.
- If the battery has been squeezed, deformed, or dropped from a high altitude, do not use it again.
- Do not expose the battery to high temperatures for extended periods. Excessive heat may increase internal pressure and lead to an explosion.
- If the aircraft has not been used for a month, remove the battery to prevent prolonged low-power discharge.
- Regularly inspect the drone for any damaged parts and replace them promptly if needed.
- Ensure the drone is properly packaged during transportation to prevent damage.
- Avoid exposing the drone to extreme conditions such as high temperatures or humidity during transport.
- Keep the drone and battery away from strong magnetic fields or static electricity.



- ⚠️ • Use 5V/3A charging plugs. Fast charging plugs exceeding 5V/3A are prohibited.



👍 USB Adapter  
(5V/3.0A)

(Not included)

- ⚠️ • It is prohibited to use computer USB, simple USB, and non-original charging cables for charging.

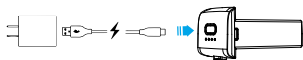

✔️ Original charging cable

❌ Computer USB



❌ Non-original charging cables



- ⚠️ • Please remove the battery in time after the aircraft has landed on low power to avoid battery damage caused by battery over-discharge.

- It is forbidden to overcharge the battery, please remove charging cable in time after fully charged to avoid damage due to overcharge.

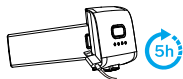

✔️ Charging Time=5 hours

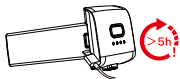

❌ Overcharge>5 hours

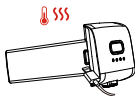

👎 Overheating warning

## 5. Flight Operation Guidelines

### 5.1 Pre-Flight Checklist

- Ensure that the remote controller, smart flight battery, and mobile device have sufficient power.
- Make sure the aircraft's arms are fully extended.
- Ensure the battery compartment cover is securely fastened and the smart flight battery is properly installed.
- Check that the propellers are not damaged, worn, or deformed, and that there are no foreign objects tangled in them. Ensure they are securely installed.
- Make sure GPS is enabled to avoid losing signal, and fly outdoors in an open area.
- Ensure your phone is properly connected to the controller. Pull out the phone holder, then insert the cable into the Type-C port at the top of the controller for data connection. Do not use the charging port on the side for data connecting, as this will prevent image transmission.
- After powering on, verify that all four motors start normally and that their speeds are consistent.
- Ensure the camera is clean.
- If replacing parts, always use original manufacturer components. Using non-original parts can pose a risk to the safe operation of the aircraft. For details on supported accessories, refer to the accessories support page in the Appendix of the user manual.

## 5.2 Operation Safety Guidelines

- Please unfold the arms of the aircraft and turn on the power before flying.
- Please pay attention to the direction of the aircraft when flying. The direction of the camera indicates the front of the aircraft.
- Do not answer calls, or text messages, or do anything that may distract you from operating your mobile phone to control the aircraft during the flight.
- Make sure that you are not under the influence of alcohol, drugs, or anesthesia, nor are you experiencing dizziness, fatigue, nausea, or any other conditions, which may impair your ability to operate the aircraft safely.
- Be sure to set the correct Return-to-Home (RTH) altitude before each flight. Ensure that your phone is correctly connected to the remote controller, with all necessary permissions enabled.
- Make sure to fly outdoors in an environment with strong GPS signals.
- When the aircraft has a sufficient GPS signal, it will remain in GPS mode and cannot switch to Attitude Mode. If GPS signal acquisition is not completed, you can manually switch to Attitude Mode by pressing and holding the compass button on the remote controller.
- After turning off the GPS, the one-button return to home, low power return, GPS follow, surround mode, route planning, and aircraft finding functions are unavailable. Flight may become unstable, requiring users to have certain operational skills and proficiency.
- Calibrate the compass and gyroscope before each flight. Otherwise, the aircraft may not function properly.
- Always maintain manual control of the aircraft during flight. Do not rely solely on the Ruko U11 App.
- GPS flight assistance features and App are only used to assist the pilot and cannot replace the pilot in controlling the aircraft. Please pay attention to the flight and operate the aircraft carefully to avoid hitting obstacles when returning.

## 6.FCC Safety and Disclaimer

### Radiation Exposure Statement

- To maintain compliance with FCC's RF Exposure guidelines, this equipment should be installed and operated with a minimum distance of 20cm from your body.
- This device complies with Part 15 of the FCC Rules. Operation is subject to the following two conditions: (1) this device may not cause harmful interference, and (2) this device must accept any interference received, including interference that may cause undesired operation.
- Changes or modifications to this unit not expressly Approved by the party responsible for compliance could void the user's authority to operate the equipment.
- Note:

This device has been confirmed to comply with the limits for a Class B digital device, pursuant to Part 15 of the FCC Rules. These limits are designed to provide reasonable protection against harmful interference in a residential installation.

This device may generate and radiate radio frequency energy and, if not installed and used in accordance with the instructions, may cause harmful interference to radio communications (which can be determined by turning the device on and off). It is recommended to eliminate the interference using the following methods:

  - Reorient or relocate the receiving antenna.
  - Increase the separation between the equipment and receiver.
  - Connect the equipment into an outlet on a circuit different from that to which the receiver is connected.
  - Consult the dealer or an experienced radio/TV technician for help.
- This device and its antenna(s) must not be co-located or operated in conjunction with any other antenna or transmitter.
- The device has been evaluated to meet general RF exposure requirement in portable exposure condition without restriction.

## 7.Disclaimer and Warning

- This product is not a toy and is not intended for use by individuals under 14 years of age. Keep out of reach of children.
- Please read the user manual carefully before first use. It is recommended to practice operating the drone in an open outdoor area with GPS mode enabled.
- Improper operation may result in personal injury or property damage.
- Users must comply with all safety guidelines and local regulations.
- Ruko shall not be held responsible for any personal injury, property damage, legal disputes, or other adverse consequences resulting from violation of safety instructions or other improper use.
- Ruko reserves the right to update this disclaimer and the associated safety guidelines at any time.
- Only upgrade software through official Ruko channels. The use of unauthorized or unverified third-party update sources is strictly prohibited.
- Do not transfer data using any untrusted external devices.
- When downloading videos, images, or firmware updates, always verify the integrity and security of the files.

# 1 Using This Manual

## 1.1 Legend

- ☑ Recommend    ☒ Warning    ⚠ Hints & Tips    📖 Reference

## 1.2 Recommendations

- Ruko U11MINI 4K provides users with instructional videos and the following documents:

- User Manual*
- Quick Start Guide*

- It is recommended that users first watch the instructional video and then read the *Quick Start Guide* to understand the use process. Please read the *User Manual* for more details.

## 1.3 Download Ruko U11 App

- Make sure to use Ruko U11 App during flight. Scan the QR code or Search in the Application store to download "Ruko U11".
- Ruko U11 App is compatible with Android 6.0 or above, iOS 10.0.2 or above.



( For Android )



( For iOS )

## 1.4 Video Tutorials

- According to the corresponding aircraft, visit the link or scan the QR code below to locate the model to watch tutorial videos or get more technical support, which how to use the aircraft safely.  
<https://rukotoy.com/support>



## 2 Product Profile

### 2.1 Introduction

- U11MINI 4K could hover and fly stably indoors and outdoors, with RTH function. The camera uses an upgraded 5GHz Wi-Fi FPV real-time transmission function, equipped with an 85° FOV lens and a 90° adjustable camera, which can stably shoot 4K HD video and 8K ultra-clear images, providing you with a broad field of vision for unforgettable moments.

### 2.2 Feature Highlights

- The U11MINI 4K drone features a foldable design, an ultra-lightweight body, and weighs less than 249 grams, so **FAA certification is not required**. It is portable, easy to operate, and allows for one-tap photo and video capture.
- U11MINI 4K's leading flight control system provides agile, stable and safe flight performance. The RTH function enables the aircraft to automatically return to the return point and land even when the remote control signal is lost or the power is insufficient.

## 2.3 Preparing the Aircraft

- All propellers are folded before the aircraft is packaged. Follow the steps below to prepare the aircraft.

1. Unfold the front arms;
2. Unfold the rear arms, then extend all propellers;
3. Remove the camera cover from the aircraft's camera.

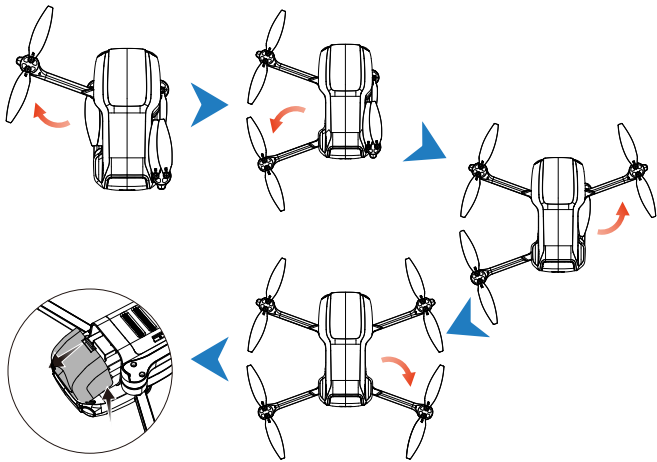

1. Unfold the front arms before unfolding the rear arms.
2. Before powering on the aircraft, ensure that the front and rear arms are extended and the aircraft is placed on the horizontal ground.



## 2.4 Aircraft Diagram

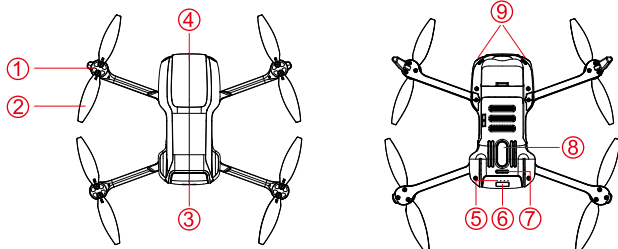

- |                         |                                |
|-------------------------|--------------------------------|
| ① Motor                 | ⑥ Power Button                 |
| ② Propellers            | ⑦ Drone Status Indicator Light |
| ③ Battery               | ⑧ Optical Flow Lens/TOF        |
| ④ Camera                | ⑨ LED Light                    |
| ⑤ Power Indicator Light |                                |

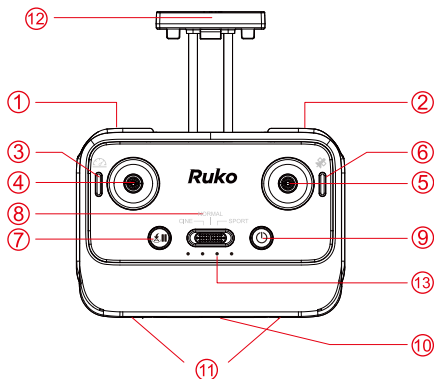

**① Gimbal Dial**

**② Photo/Record Button**

Short press once to take a picture. Long press once to start recording mode, repeat to stop recording.

**③ Auto-Cruise Control**

By operating the remote control stick and briefly pressing the button, then releasing the stick, the drone will automatically fly according to the control movements, activating the speed control auto-cruise mode.

**④ Left Control Joystick**

(American control joystick)The left control joystick can adjust the aircraft's altitude and nose direction (Up/Down, Left Rotation/Right Rotation).

**⑤ Right Control Joystick**

(American control joystick)The right control joystick can adjust the aircraft's flight direction (forward /backward /left/right).

**⑥ Camera One-touch Adjustment /Flight Mode Switch**

Short press the button to adjust the camera. Long press the button to enter Indoor Attitude Mode.

**⑦ One Key Return**

Press once briefly, and the drone will automatically return to the take-off position (due to GPS signal issues, the landing position may slightly deviate from the take-off position, with a deviation range of about 9.84 feet in diameter); pressing once during the return will cancel the intelligent return. Press and hold the button to activate the buzzer (the buzzer can only be turned on when the motor is not running).

**⑧ Speed Adjustment (3 speed in total)**

Left: low speed

Middle: medium speed

Right: high speed

**⑨ Power Switch**

Long press to turn on the power, repeat to turn off

**⑩ Charging Hole**

**⑪ Joystick Storage Hole**

**⑫ Cell Phone Holder**

**⑬ Indicator Light**

## 3 Aircraft

- The Ruko U11MINI 4K drone mainly consists of a remote controller, a gimbal stabilization system, a communication system, a video downlink system, a propulsion system, and an intelligent flight battery. This section will provide a detailed description of the functions of each component.

### 3.1 Flight Speed Mode













- Ruko U11MINI 4K has three types of speed: low speed, medium speed and high speed, which can be adjusted by pressing the speed button to meet your different flight speed experience.



1. Low speed, maximum speed: 4.5m/s; Medium speed, maximum speed: 8m/s; High speed, maximum speed: 14m/s
2. When wind speed is high, sport mode should be maintained to improve wind resistance effect. High speed mode is sport mode.
3. When flying in sport mode, the pilot should reserve at least 3 meters of braking distance to ensure flight safety.
4. When flying in sport mode, the power of the aircraft will be greatly improved, please reserve enough flying space to ensure the safety of the flight.



### 3.2 Calibration and Aircraft Status Indicator

- The U11MINI 4K aircraft's status indicator is located under the rear arm of aircraft to indicate the current status of the flight control system. Please refer to the following table for the status of the flight control system represented by different blinking modes.

	Blinking status of the indicator		Conditions
Aircraft		The red light blinks twice at short intervals	The remote controller and the drone are starting to match
		Slow flash	Pairing complete. The drone is searching for GPS signals
		Slow flash	Drone low battery
		Stay on	Complete GPS signal search
		Green light out	Start compass calibration
		Stay on	Indoor attitude model
		Quick flashing	Start gyroscope calibration
Remote Controller		Flash	GPS search in progress
		Stay on	Star search successful
		Extinguish	Turn off GPS and enter attitude mode
		Remote controller battery indicator	Display remote control battery level
		Flash quickly together	The remote controller and the drone are starting to pair
		Three green lights flashing slowly together	Drone low battery
		Three green lights flash in turn	The drone is returning
		Blue light and three green lights flash in turn	The remote controller is charging





### 3.3 Return to Home

- The U11MINI 4K aircraft has an automatic return-to-home function in GPS mode, making the aircraft return to the take-off point. The Return to Home (RTH) function brings the aircraft back to the last recorded home point. There are three types of RTH: Smart RTH, Low Battery RTH, and Signal Loss RTH. If you activate the RTH function under the condition that the aircraft successfully recorded the home point and GPS signal is good, the aircraft will automatically return to the home point and land.

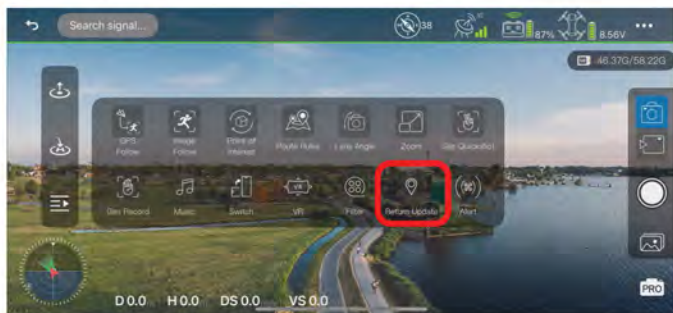
	GPS	Description
		<p>When flying outdoors, the GPS signal icon is displayed with <b>3 bars</b> or more for the first time, and the take-off location will record the aircraft's current position as the Home Point. During the flight, if the aircraft lands at a new location, the point from which it retook off will become the latest home point, and the aircraft will return to the latest home point.</p>

- When the drone is not unlocked, press and hold the return key to activate the drone's buzzer, which can be used for locating the drone and assisting in finding it.
- After the drone acquires a GPS signal and takes off outdoors, the return point location can be updated via the App.





 Drone location	 New return point location
 Original return point location	 Remote control location

- You can select a new return point location on the map or set the latest location of the drone or remote controller as the new return point location.

**1. Select a new return point location:**

- Drag freely on the App map to select a new return point.
- Tap "Update" to complete the setup.

**2.  Drone location:**

- Tap "Drone location."
- Tap  will navigate to the current location of the drone.
- Tap "OK" to complete the setup.

**3.  Remote control location:**

- Tap "Remote control location."
- Tap  will navigate to the current location of the remote controller.
- Tap "OK" to complete the setup.

**Complete setting**

- After the new return point is set, a confirmation popup will appear, indicating that the new return point has been successfully configured.



- **Warm Tip:**  
It can be used after the drone takes off in GPS mode.

## Smart RTH

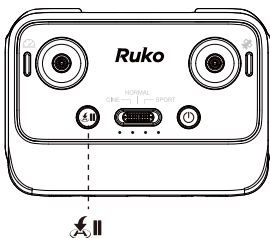

### Return

During the flight, press the "🚁⏏" button, the remote control will make a "di" sound, and the aircraft will return to the take-off point automatically. During the return flight, the power indicator of the remote control will flash cyclically.

### Stop return

To stop the return flight, just press this button again.

1. When the pilot needs the aircraft to return home automatically, you can press the smart RTH button (🚁⏏) on remote controller or tap the return icon (🚁⏏) on the App interface to start RTH.
2. During the return process, the user can operate the aircraft to ascend, descend, forward, backward, fly to the left or right to avoid obstacles.
3. During the return home, short press the smart return button on the remote controller or tap the return icon (🚁⏏) on the U11MINI 4K interface again to exit the return home.



**Note:**

- If the return-to-home altitude is not set and the drone's flight altitude is below 65 feet (20 meters), the drone will automatically ascend to the default return-to-home altitude of 65 feet (20 meters) before returning. If the drone's flight altitude is above 65 feet (20 meters), it will return at its current altitude.

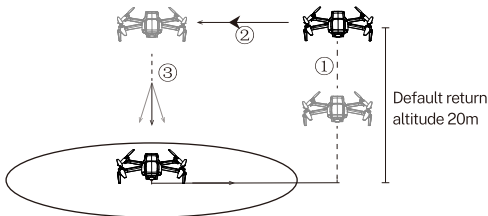

- 65ft (20m) is the default return height. The return height range that can be set in the App is 10-120 meters.
- If a return-to-home altitude is set and the drone's flight altitude is below the set return-to-home altitude, the drone will automatically ascend to the set altitude before returning. If the drone's flight altitude is above the set return-to-home altitude, it will return at its current altitude.

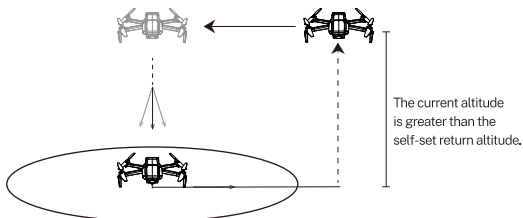

- The drone is not equipped with an obstacle avoidance function. During the flight, please assess the flight situation reasonably, avoid obstacles in time, and set the corresponding flight and return height according to the flight environment.

## Low Battery RTH

- When the intelligent flight battery is too low or there is not enough power to return home, the user should land the aircraft as soon as possible to avoid aircraft damage or other dangers.
- In order to prevent unnecessary dangers due to insufficient battery power, when the aircraft battery power is low, the low battery return home function will be automatically triggered. According to the remaining power after returning, there are 2 situations after returning:
  1. First-level low battery: the aircraft returns to the point 98 feet (30 meters) above the take off point and hover. After hovering, you can continue flying the aircraft at a height of 98 feet (30 meters) and within a radius of 98 feet (30 meters).

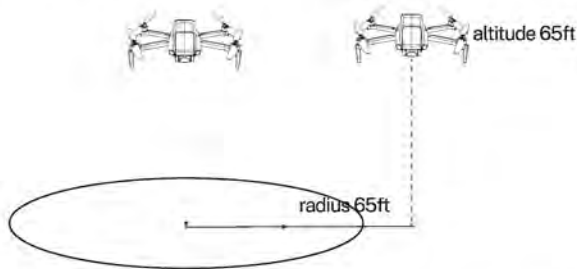

2. Second-level low battery: The aircraft will directly descend from its current altitude to the ground.



3. In the event of a special situation during low battery return, you can cancel the return and take control.
  - Tap the return button on the remote controller or the return button on the App.
  - After tapping the confirmation button on the App's pop-up, the return will be canceled.

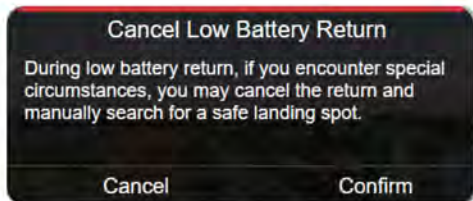

- After cancellation, you can take control of the drone, but you can only operate the drone to fly toward the return point.



- Must pay attention to the flight altitude when the battery is low. Avoid hitting obstacles due to the low flying altitude when returning home with the second-level low battery.
- The remaining power after returning is related to the return distance, wind speed, and wind direction.

## Lost Signal RTH

- If the drone loses signal for over 10 seconds, it will auto-enter auto-return mode. The remote will beep, flash, and the app will show a warning. If the signal returns, the drone keeps returning unless you press the RTH button to cancel and regain control.

### Automatically Return to Home:

1. Aircraft stores its position when taking off after the GPS signal is successfully received, and records it as the home point.
2. Loss of signal will trigger RTH 10 seconds later (triggered by low battery of remote controller, signal loss, etc.).
3. After triggering the Return-to-Home function, the aircraft adjusts the nose direction and starts to return home.
4. The aircraft automatically flies over the home point, then starts to land, and completes the home return.



#### Note:

- When out of control, the aircraft cannot avoid obstacles.
- When the GPS signal is weak, the aircraft cannot return to home automatically.

### 3.4 Optical Flow Positioning/TOF (Indoor Attitude Mode)

- The underside of the aircraft is equipped with a downlook optical flow system and a TOF altitude sensor, which allows the aircraft to better adapt to its environment.
- The downlook optical flow system, consisting of downlook vision camera sensors, enables the drone to hover stably at low altitude in indoor attitude mode without GPS.

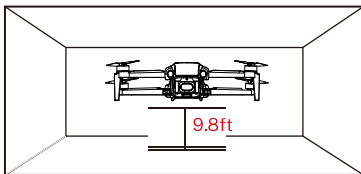

#### Note:

1. The optical flow vision system can only assist flight when the surrounding environment is well lit and rich in texture, can not completely replace the user's judgement.
2. The optical flow vision system may be ineffective or perform poorly in environments with excessively bright or dark lighting, mirrors, solid-colored smooth surfaces, water, reflective materials, or sparsely textured areas.
3. The optimal working range of the optical flow vision system is below 3 meters and above 0.5 meters, beyond the range, the positioning of the optical flow vision system may be poor, please fly carefully.
4. Please make sure that the optical flow vision system lens is clear. And it can only be used in the attitude mode.



- If the GPS signal is weak and you are flying indoors, you will need to manually turn off the GPS and switch to the indoor attitude mode before take-off.
- Once GPS is turned off, the drone will not be able to return automatically, and the smart flight feature will not be used.

## 3.5 Intelligent Flight Mode

- The U11MINI 4K features 6 intelligent flight modes: Route Rules, GPS Follow, Point of Interest, Gesture Quickshot/Gesture Recording, Image Follow, and Auto-Cruise Control. Depending on the user's shooting needs, the operation can be completed with a single tap, making it simple and fast.



**Route Rules:** In this mode, aircraft flies along paths marked with way points.



**GPS Follow:** In this mode, the aircraft will lock on to the user and automatically follow the operator's movement trajectory to capture and shoot.



**Point of Interest:** In this mode, the aircraft is centered on the location set on the App, flying around at a specific distance to shoot.



**Ges Quickshot/Ges Record:** The aircraft takes pictures or videos according to the steering instructions of different gestures.



**Image Follow:** Image Follow function enables the drone to follow the object's in circle movement to rotate.



**Auto-Cruise Control:** The drone automatically flies at a constant speed according to the current flight action under strong GPS signal.

## Route Rules





1. Ensure that you have downloaded the Ruko U11 App on your phone.
2. Connect the phone with the remote control via the data cable and open the App.
3. After the aircraft takes off, in GPS mode, tap the icon(  ).
4. Mark the points (up to 16) which you plan to fly on App map's within red circle (limited flight range).
5. Tap "Delete Single Point" or "Delete All" to reset the marked point.
6. Make sure the marks are correct, tap "Send", The aircraft will start waypoint flight.

Note: Push right joystick to cancel waypoint flight function.



## GPS Follow



1. Ensure that you have downloaded the Ruko U11 App on your phone.
2. Turn on the smartphone's GPS location; connect the phone with the remote control via the data cable and open the App.
3. After the aircraft takes off, the best effect is to ensure that the flight range is within 50 meters in an open environment with good GPS signal.
4. Tap the (  ) icon on the App interface to start the (  ) mode.
5. "GPS Follow" (  ) will be displayed on the App interface and try to fly. The aircraft will track your movements to fly.
6. Tap the icon on the App interface again to exit the GPS Follow mode.

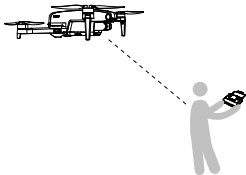

- The GPS Follow function only works when the GPS signal is strong. Please avoid high buildings, trees, and areas where signal might be interfered.
- In GPS Follow mode, the drone maintains stable flight at speeds of up to 17 m/s.
- Aircraft is not equipped with obstacle avoidance function. Please use it in open areas free of obstacles.



## Point of Interest

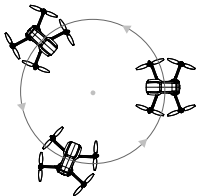

1. Ensure that you have downloaded the Ruko U11 App on your phone.
2. Turn on the smartphone's GPS location; connect the phone with the remote control via the data cable and open the App.
3. Launch the aircraft and make it hover around the target center point. Fly to the target point where you want the aircraft to fly around.
4. Tap the (  ) icon on the App to activate Fly Around mode.
5. Move the right joystick forward and backward to set the radius of the drone to fly (within 5-50 meters).
6. The aircraft begins to orbit according to the radius set in step 5.
7. Tap the icon on the App interface again to exit the Point of Interest.



- The default minimum surround mode radius is 16 feet (5m).
- Move the right joystick left and right to adjust the circling speed and direction.

## Auto-Cruise Control





- This function can only be used in GPS mode and when sufficient satellite signals are detected.
1. Set the desired flight distance and altitude.
  2. Fly the drone to an altitude above 15 meters (this function cannot be used below 15 meters).
  3. Operate the left or right joystick, then briefly press the cruise control button once more.
  4. Release the joystick; the drone will automatically fly according to your input (for example, if you push the right joystick forward, the drone will automatically fly forward).
  5. During automatic flight, you can use the remote control to correct the drone's flight direction and altitude. Press the cruise control button again while operating, and upon releasing the joystick, the drone will continue to cruise at your latest input.
  6. To exit cruise control mode without operating the joysticks, briefly press the cruise control button or tap "Cancel" in the App.



- The drone cannot use this function if the flight altitude is below 15 meters.
- The function cannot be used when the drone's battery is low.
- The drone will automatically exit this function after reaching the set distance.
- If the drone descends to 15 meters during automatic cruising, it will automatically exit this function.
- The drone does not have obstacle avoidance features. Please ensure flight safety.

## Ges Quickshot/Ges Record



1. Ensure that you have downloaded the Ruko U11 App on your phone. Turn on the smartphone's GPS location. Connect the phone with the remote control via the data cable and open the App.
2. After the drone takes off, use it in GPS mode.
3. Open the App, tap the Multi-function icon on the App interface, and tap the (  ) icon. In this mode, raise the right hand and pose (  ) at the same height of the shoulder to take photos.
4. Tap the (  ) icon. In this mode, raise your right hand and show your palm at the same height of the shoulder to open the recording mode.



- Use in a well-lit environment. Tap the icon again to exit Ges Quickshot/Ges Record mode.
- Ges Quickshot/Ges Record mode can only be activated with the right hand.

## Image Follow





1. Launch aircraft and ensure flight height is higher than the nearby obstructions, access to the App CONTROL interface.

2. Tap (  ), slide to start and tap on the object or person plans to track, tap to confirm the selection, drone rotates following the object's in circle movement.

Note: Make sure the size of the frame isn't too large, so as to ensure the recognition is achievable.

### 3.6 Propeller

- The adjacent propellers on the motors of the U11MINI 4K are forward and reverse propellers. The two propellers on the same motor are the same, and the propellers are marked with A and B respectively.
- The rotation directions of the propellers with the same mark are the same.

Propellers	Mark A	Mark B
		
Installation location	Installed to the motor with A mark on the arm	Installed to the motor with B mark on the arm

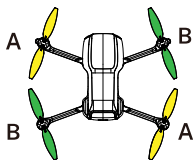
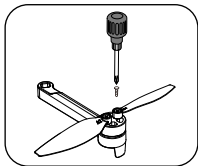

Installation location

## Attaching the Propellers

- Taking the camera direction as the front, the left front arm and right rear arm must be equipped with propellers marked with A; the right front arm and left rear arm must be equipped with propellers marked with B. Use a screwdriver to install and make sure the screws are tightened.

## Detaching the Propellers

- Use the screwdriver to detach the propellers from the motors.



- Please use the propellers provided by Ruko, and do not mix propellers of different types.
- Please check whether the propeller is installed correctly and tightly before each flight.
- Before each flight, please check to make sure that the propellers are in good condition.

## 3.7 Intelligent Flight Battery

- The U11MINI 4K intelligent flight battery has a capacity of 2200mAh, a rated voltage of 7.6V, and with charge and discharge management functions. This battery uses high-energy and large-capacity batteries to increase the flight time of the aircraft.

## Battery Features

1. Balance Protection: Automatically balance the internal battery cell voltage to protect the battery.
2. Overcharge Protection: Overcharge will seriously damage the battery. When the battery is full, remove the charger device in time.
3. Over-discharge Protection: Over-discharge will seriously damage the battery. When the battery is not used for flight, the battery will automatically discharge to protect the battery life.
4. Short Circuit Protection: When the battery detects a short circuit, the output will be cut off to protect the battery.
5. Easy Charging: Use Android charger and USB head, but for best performance, please use Ruko charger. Please avoid chargers over 12V.



- Please read carefully and strictly abide by Ruko's Requirements in this User Manual, Quick Start Guide. The stickers on the battery surface before using the battery. The user shall bear the consequences caused by failure to use it as required.

## Using the Battery

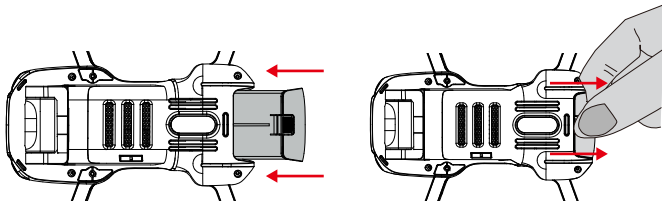

- Install the intelligent flight battery into the battery compartment and push it down until you hear a "click" from the battery buckle, indicating that it has locked into place. Make sure the battery is in place.
- To remove the battery, press the buckles on both sides of the battery and pull it out of the battery compartment.



- Do not install the battery into the aircraft or remove the battery from the aircraft when the battery power is turned on. Otherwise, the poor contact of the battery interface during the operation may cause the battery to short-circuit and burn the aircraft.
- The battery must be installed or removed with the battery power turned off.

### Checking Battery Power

- Turn on the power and check the current battery.

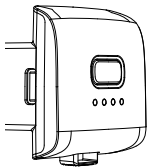

Low — Battery Level — High



### Powering On

- Press and hold the power button. When the fourth indicator light turns on, release the button to check the current battery power.

## Powering Off

- Press and hold the power button until all lights are off and release the power button. After closing, the indicators are off.



- **Note:** The drone has an automatic shutdown function. If there is no operation (not being taken off), the drone will automatically shut down after 10 minutes of being turned on.

## Charging the Battery

- Before using the intelligent flight battery, be sure to fully charge it.
1. Please use a 5V/2A or 5V/3A USB charging plug.
  2. In the charging state, the battery power indicator will flash and indicate the current charge level; when the fourth indicator light is always on, it indicates that the charging is complete.
  3. After charging is complete, please remove the charger in time.

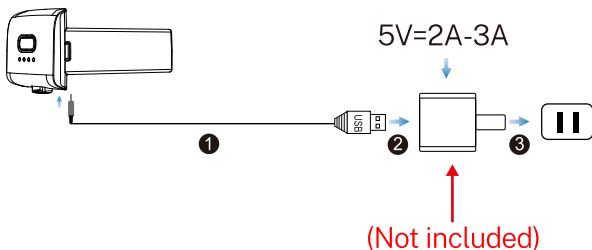



## 3.8 Camera Overview

- The camera features an upgraded 5GHz Wi-Fi FPV real-time transmission function, equipped with an 85° FOV lens, a 90° adjustable camera, and a three-axis brushless gimbal for stabilization. This setup allows for stable shooting of 4K HD video and 8K ultra-clear images, providing you with a wide field of view to fully enjoy unforgettable moments.

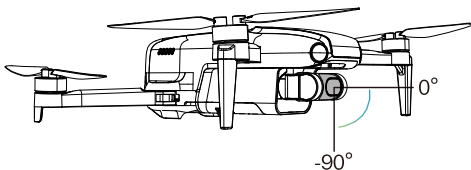

- The gimbal features a three-axis mechanical stabilization system, EIS electronic stabilization, and axes for roll and pitch. The yaw axis uses a brushless motor combined with EIS technology.

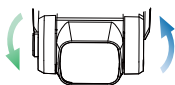

Roll Axis

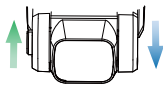

Tilt Axis

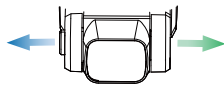

Yaw Axis

- The gimbal will not operate and will remain tilted when it is powered off or during compass calibration, which is normal. Once powered on and calibration is complete, the gimbal will automatically perform a self-check and enter working mode, taking about 20 seconds to stabilize in a level position. Be careful not to touch the drone during calibration.



- The drone's gimbal is a movable mechanical structure, and it is normal for the gimbal to appear tilted when powered off.
- If the drone takes off from grass, the gimbal may fail the self-check if it comes into contact with the grass. To avoid this, use a launch pad or cardboard to prevent the gimbal from hitting foreign objects.
- Taking off from a floor, roadside, or table may cause vibrations that lead to gimbal self-check failures. Avoid using the drone in areas that produce significant vibrations.
- The gimbal will not work during compass calibration. Once the calibration is complete, place the drone on a level surface, and it will automatically enter working mode.

## Storing Photos and Videos

- U11MINI 4K is equipped with a micro SD card slot for storage space expansion.
  - 1.Card speed: 10M/s.
  - 2.File format: support FAT32 format.
  - 3.Memory capacity: a memory card with a memory capacity of 256G or less.
- The mobile phone and the memory card store photos and videos at the same time. If you want clearer videos, please download the video file on the memory card.



1. Check whether the capacity of the memory card is sufficient. If the capacity of the memory card is insufficient, videos and pictures cannot be stored.
2. If you cannot save pictures or videos, try formatting the memory card.
3. You must turn on the aircraft and connect App to copy or download the photos or videos stored in the aircraft memory card to the phone.
4. Please turn off the aircraft correctly, otherwise the camera parameters will not be saved and the video being recorded will be damaged. Ruko is not responsible for any damage caused by the inability to read videos and photos.
5. Do not touch the SD card slot directly with your hand during use, and be cautious of high temperatures.

## 4 Remote Controller

### 4.1 Remote Controller Profile

- U11MINI 4K remote controller uses the 5 GHz frequency band. The folding handle can stably place the mobile phone, and the maximum adjustable width is 3.15 inches.
- Remote controller built-in 1500mAh capacity battery, charging time is 80 minutes.

## 4.2 Using the Remote Controller

### Install Joystick

- When leaving the factory, the joystick is placed in the packaging bag of the product. When using, the joystick should be installed on the remote control as shown below.

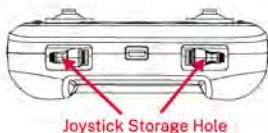

- Unfold the phone clip and install the phone.

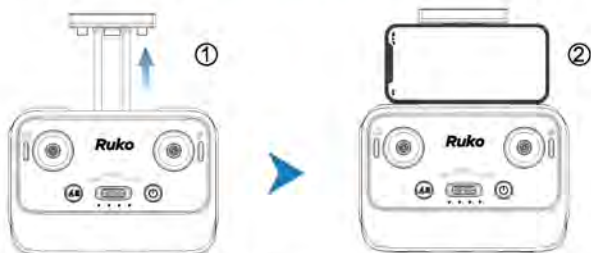

- Connect the phone with remote control via data cable.

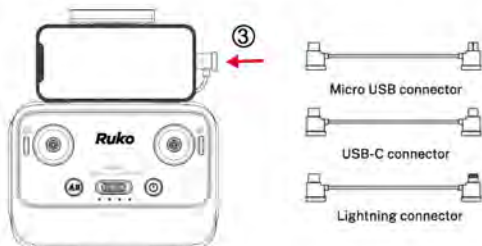



- Note: Equipped with 3 different types of data cable, please choose the data cable suitable for your phone to connect. (The USB-C data cable is in the remote control, and the other two are in the packaging box )

Please correctly set the USB Settings option that pops up. Select "Transterring files" for Android phones, and "Trust" for iPhones. Some USB Settings of Android phones are hidden in the "Developer options", you need to change the "Default USB configuration" to "Transferring files" after opening the developer mode.

### Powering On/Off

- Turn on the remote control: Press the power button for 3 seconds to turn it on.
- Turn off the remote control: Press the power button for another 3 seconds to turn it off.

### Charging the Controller Battery

- Connect the remote controller Micro USB interface to the charger for charging. Do not use a fast charger that exceeds the rated power. A 5V/2A or 5V/3A charger is recommended.

1. Charging: The four lights flash in turn.
2. Charging is completed: 4 indicators are on.

5V/2A-3A Adapter  
(Not Including)

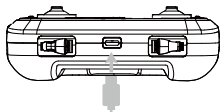
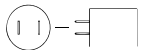

## Controlling the Camera

1. Photo/Record Button:  
Tap once to take a picture.  
Press and hold 3 seconds to start/stop recording.
2. Gimbal Adjustment:  
Turn the gimbal dial to adjust the Angle.  
Quick down or up with one press.

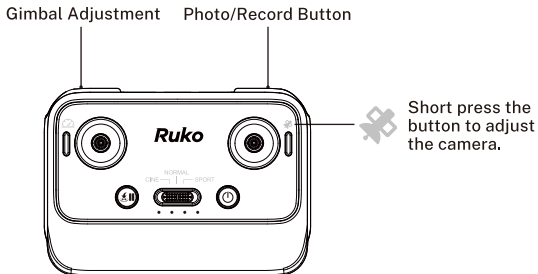

## Joystick Control Aircraft

- The control method of the remote controller joystick is as follows:  
American hand's control ( Mode 1 )

American hand's control ( Mode 1 )

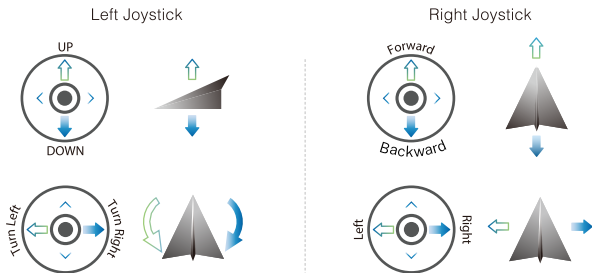

- Switching to Japanese Hand's Control Stick:
  1. Turn on the aircraft.
  2. Press and hold the record button to turn on the power of the remote controller.

#### Japanese hand's control (Mode 2)

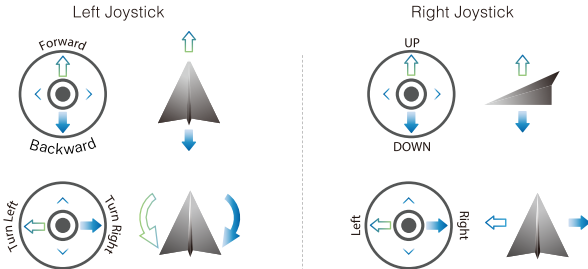

#### Smart RTH Button

- Tap the smart RTH button on the remote controller, and the aircraft will activate the automatic return function. Tap it again to exit the smart return. The aircraft is hovering in the mid-air of the return. At this time, you can operate the joystick to control the aircraft.

## 4.3 Communication Range of Remote Controller

- When controlling the aircraft, the position and distance between the remote controller and the aircraft should be adjusted in time, and the antenna position should be adjusted to ensure that the aircraft is always within the best communication range.

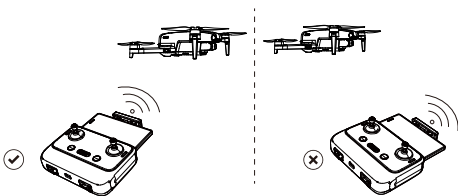

- Install the mobile phone into the remote controller bracket, refer to the aircraft flight direction of the Attitude Indicator in the App, and the attitude Indicator points straight ahead (perpendicular to the coordinates), indicating that the remote controller is facing the aircraft.



## 4.4 Matching the Remote Controller

- Each time drone flights, it needs to be matched with the remote control. The flight of the drone can be controlled only after the frequency pairing is successful. The steps for the pairing are as follows:
  1. Turn on aircraft.
  2. Turn on remote controller.

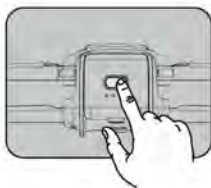



3.The drone and remote control will automatically complete the frequency pair, and the frequency alignment time is about 30 seconds.

4.Connect the mobile phone with the remote control to enter the App control interface; The phone displays information such as the power signal of the remote control and the camera screen indicates that the frequency is successfully matched.



- The remote controller pairs with aircraft successfully :
  - 1.The drone lights will change from red to green.
  - 2.The green light of the remote control changes from blinking to steady on.



- The drone and the remote control will automatically connect, the connection time is about 30 seconds. Please check the remote control power before each flight. The remote control will sound a tone when the battery is low.
- The remote control will automatically shut down after being idle for 10 minutes, and the remote control can be restored to normal working state by flipping the joystick or pressing any key.
- When using the remote control handle to grip the mobile device, be sure to press tightly to avoid the mobile device slipping.
- Keep the battery at around 7.8-7.9V, and recharge it every month or so to keep the battery active.

## 5 Ruko U11 App

### 5.1 Home

- After running Ruko U11 App, enter the homepage.



#### CONTROLS

- Operate the aircraft through the App page buttons to realize the functions of the aircraft.

#### GUIDE

- Tap to view the Help manual, Instructions videos and Quick start.

#### FREE CALL

- Tap to call customer support.















#### SUPPORT

- Tap to access technical support, after-sales service.

## 5.2 Control Interface



Back	GPS Status
Controller Battery Level	Aircraft Battery Level
Auto Takeoff/Landing	Return to Home
Shutter	Photo/Video
Photo Album	Image Parameter Adjustment: White Balance Sharpening Contrast Brightness Saturation
<ol style="list-style-type: none"> <li>SD card capacity display</li> <li>Format : Tap to format when the memory card is loaded and cannot be recognized or save files</li> </ol>	
Compass Interference Value	A higher value indicates greater ambient interference . Reaching 200 will prompt compass calibration, and reaching 400 will force entry into compass calibration
D 0.0m H 0.0m DS 0.0m/s VS 0.0m/s	D : Distance H : Height DS : Flight Speed VS : Ascent and Descent Speed

	<b>GPS Follow</b>	Aircraft will lock onto the user and can track the user's movement as he moves
	<b>Image Follow</b>	The aircraft camera will slowly rotate to follow the target
	<b>Point of Interest</b>	The aircraft fly around in circle with the current position as the center
	<b>Route Rules</b>	Aircraft flies along the path marked on the App
	<b>Lens Angle</b>	Adjust the shooting angle of the aircraft camera
	<b>Zoom</b>	Optional 5x zoom
	<b>Ges Quickshot</b>	Recognize your gestures and automatically take photos
	<b>Ges Record</b>	Tap to recognize your gesture automatically record
	<b>Music</b>	Select music for the video
	<b>Switch</b>	Switches three vertical screen functions
	<b>VR</b>	VR split screen interface , used with VR glasses
	<b>Filter</b>	Select a filter for your photo or video
	<b>Return Update</b>	Select a new return point location on the map
	<b>Alert</b>	When the drone is not unlocked, tap "Alert" on the App will turn on the drone's buzzer

## Safety



- **Beginner Mode:** In this mode, the aircraft's farthest flight distance and altitude is 98ft so that the aircraft can fly more safely within sight.
- **Flight Distance:** Set the longest distance to fly.
- **Flight Height :** Set the maximum flight height.
- **Gyroscope Calibration:** When the drone is unstable, it can be placed horizontally to re-calibrate.
- **Compass Calibration:** Calibrate the compass first when flying in a new location or complex environment.

## Settings

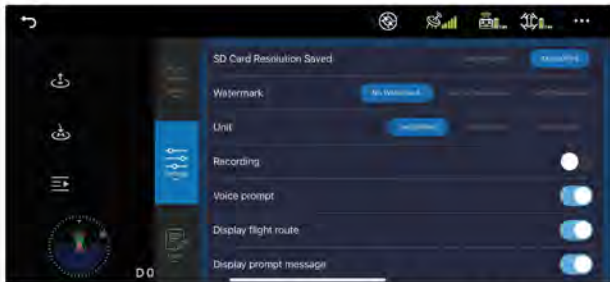

1. SD Card Resolution Saved: Set the smooth mode or default mode.
2. Watermark: Choose from 2 kinds of watermarks.
3. Unit: Switch between metric and imperial units of measurement.
4. Recording: When recording a video, you can record the sound into the video.
5. Voice prompt: Voice prompts the status of the drone when the App is opened or closed.
6. Display prompt message: Switch on or off the prompt bar.

## Track



- All Flight Records: The date, location, distance, duration and maximum altitude of each flight.
- Find Drone: It shows the last position of the aircraft when it lost the image transmission signal. Open the map to find the position where the aircraft is disconnected from the App.
- Flight Logs: You can export the flight log data.
- Drone Information Display: App version, Wi-Fi version, ID number.



- Before using the Ruko U11 App, please correctly enable the required permissions for the App.
- Allow Ruko U11MINI 4K to get your location. Otherwise, the following functions cannot be realized.
- Allow Ruko U11MINI 4K to connect to the mobile phone on the local network, otherwise you will not be able to see the aircraft image transmission screen.
- Allow Ruko U11MINI 4K to access to albums, recordings and other permissions.
- When using the Ruko U11 App on your phone, please keep your phone running smoothly and close other background software that you do not use.
- The map used in the map interface needs to be downloaded from the Internet before using.

## 6 Flight

- After the installation preparation is complete, please conduct flight training or training first. It is recommended to conduct training in the beginner mode. Please choose a suitable flight environment when flying. The flying altitude is limited to 393ft, and the local laws and regulations must be strictly observed during flight. Please be sure to read the U11MINI 4K Disclaimer and Safety Summary, and understand the safety precautions before flying.

### 6.1 Flight Environment Requirements

1. Do not fly in severe weather such as strong wind, snow, rain, and fog.
2. Choose an open place with no obstructions around as the flying field. The compass and GPS signals on the Aircraft will be interfered by buildings, mountains, and trees. It is recommended to fly in an open space with a diameter of 33ft without interference. It is recommended that the flight altitude be greater than 49ft to avoid ground obstacles and other signal interference from the ground.
3. When flying, keep in sight and control, and stay away from obstacles, crowds, etc. When flying on the water surface, please be more than 9ft above the water surface.
4. The remote control may be interfered by high-voltage lines, communication base stations or transmission towers. Please fly away from these areas.
5. Please fly below 9842ft above sea level to ensure that the Air pressure setting function of the Aircraft can work normally.
6. When GPS is active, the Aircraft can achieve stable hovering, intelligent return to home, and intelligent flight functions. When the GPS function fails, these functions cannot be implemented. The Aircraft will be unable to hover, drifting away in the direction of the wind.



## 6.2 Connection&Settings

1. Choose the Appropriate data cable to connect your phone to the remote controller.

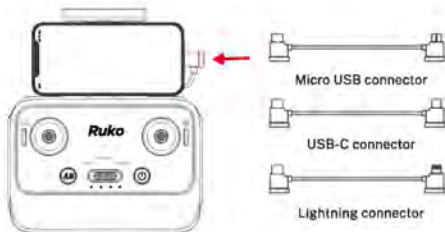

2. Tap the App, the first time to use the interface will pop up the permission setting.

### Please allow the following permissions

1. Mobile phone location rights
2. Network rights
3. Recording rights
4. Album access rights



**iPhone Settings**



**Android phone USB Settings**

3. When you enter the operation interface and see the image transmission screen of the drone, the connection is successful.



1. When connecting the data cable, ensure that the plug of the data cable is in place.
2. For some mobile phones, due to the reasons of the phone case, the plug of the data cable is not installed in place, resulting in data transmission failure, poor contact, and no way to see the transmitted image.
3. Please set the permissions required by the App correctly to avoid the inability to preview the image.
4. USB Settings on some Android phones are hidden in the "Developer options", you need to change the "Default USB configuration" to "Transferring files" after opening the developer mode.  
(The way to open "Developer options" varies depending on the phone model. You can search Google for details).

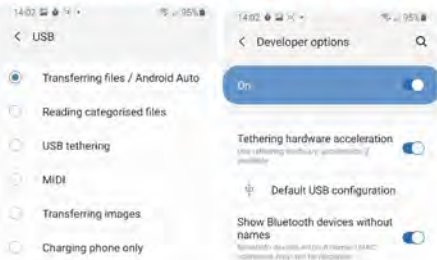

## 6.3 Calibration before Flight

### Calibrate the Compass

- When the drone flies in a complex environment or when the magnetic field interference exceeds the set value, it is necessary to calibrate the compass.

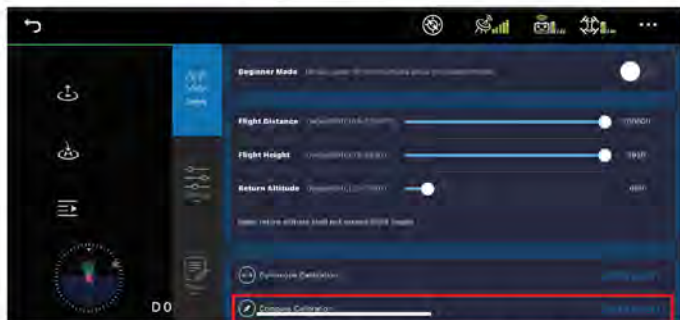

- Push the left and right joysticks to the "11 o'clock" and "1 o'clock" hold for 2 seconds (as shown in picture 1) or tap "Compass calibration" on the App calibration interface (as shown in picture 2) to turn off the green light of the drone and enter the calibration step.

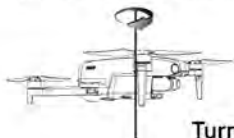

Turn 3 times

2. At this time, you need to follow the prompts to pick up the Aircraft at a distance of 3.28ft from the ground and rotate the Aircraft horizontally for 3 laps until the App interface prompts to enter the vertical calibration.
3. Pick up the Aircraft at a distance of 3.28ft from the ground, and rotate the Aircraft 3 laps vertically with the camera facing upwards until the prompt of vertical calibration on the App interface disappears. After the compass calibration is completed, place the Aircraft on a level ground. At this time, the three lights of the drone flash in turn.



**Turn 3 times**



- Before the flight, pay attention to the compass interference value on the App. (  )When the interference value is close to 120, we can manually calibrate the compass, or change the environment to fly. When the interference value exceeds 180, the drone will automatically enter the compass calibration.
- When the Aircraft is flying in a circle or out of control in a complex environment, the aircraft compass calibration is not standard or interfered. Please land the Aircraft manually in time to manually calibrate the Aircraft (refer to the first step of calibrating the compass).
- When calibrating the Aircraft, please open the arm and keep the aircraft 1 meter above the ground to avoid the influence of the magnetic field of the motor.

## Calibrate the Gyroscope

1. Make sure that the Aircraft is placed on a level ground.
2. It can be calibrated by gyroscope calibration function of App.



- Or push the right joystick of the remote control to the "5 o'clock" position for calibration.
3. The rear light flashes quickly, and the drone enters horizontal automatic calibration.
  4. The light changes back to the original light state, indicating that the calibration is complete.
  5. "Fly" is displayed in the App, and you can now prepare to take off.



- When the Aircraft's flight state is tilted and unstable, please land the Aircraft on a level ground for gyroscope/horizontal calibration.
- When the tilt Angle of the fuselage is greater than  $10^{\circ}$ , the horizontal correction cannot be performed.

## 6.4 Starting/Stopping the Motors

### Starting the Motors

- Push the joysticks into 5 & 7 o'clock positions to start the motor. After the motor starts, please release the joystick immediately.

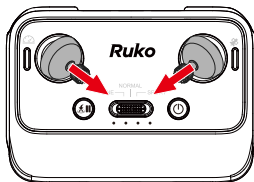

- Stopping the Motors  
After the motor starts rotating, there are two ways to stop:
- Method 1: After the Aircraft takes off, push the throttle stick to the lowest position and operate the Aircraft to land until the motor stops, then release the joystick.
- Method 2: When the flight is not taking off, Push the joysticks into 5 & 7 o'clock position to stop the motor. After the motor is turned off, please release the joystick immediately.



- When manually landing the aircraft, continue to pull down the remote control throttle lever, landing 1.6 ft (0.5 meters) will stop, confirm the landing continue to pull down the throttle lever, the drone will land and stop the motor.
- Please choose the flat surface to landing.

## 6.5 Auto Takeoff/Landing

### Auto Takeoff

- After the Aircraft is calibrated, users can use the take-off function on the App:
  1. Start the motor after confirming the safe take-off conditions.
  2. Tap "↑" on the App to take off.
  3. Slide to unlock motor.
  4. Press the One-key Takeoff button on remote controller or enter the App and tap to take off.
  5. The Aircraft will take off automatically and hover at a distance of 1.5m(4.9ft) from the ground.



## Auto Landing

- After the aircraft takes off, the user can choose to use the automatic landing function on the App:
1. Confirm the safe landing conditions, tap the "🚁" on the App.
  2. Slide to confirm automatic landing.
  3. The aircraft descends to the ground and turns off its motors.

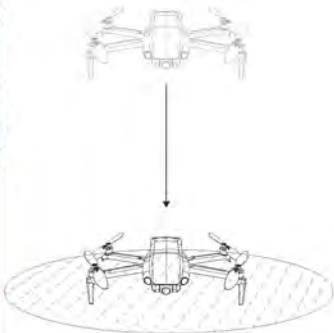
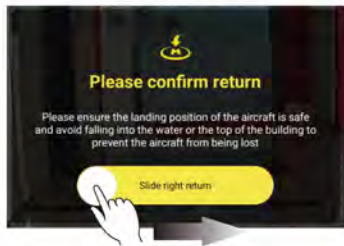



## 6.6 Basic Flight Steps

### Basic Flight Steps

1. Place the Aircraft on a flat and open ground with the nose facing forward and the tail facing the pilot.
2. Press and hold to turn on the aircraft power.
3. Long press to turn on the remote control power, the drone and the remote control will automatically match the frequency, the time is about 30 seconds.
4. After a successful match, connect the phone to the remote control through the data cable (pay attention to the USB permission setting)
5. Open the Ruko U11 App, and enter the operation interface.
6. GPS signal search is completed, and the drone light is green and on.
7. Unlock and start the motor.
8. Slowly push the throttle stick upward to let the Aircraft take off smoothly.
9. Pull down the throttle stick to lower the Aircraft.
10. After landing, pull the throttle stick to the lowest position and hold it until the motor stops.
11. Turn off the power of Aircraft and Remote control.

### Aerial Photography Tips & Tricks

1. Perform pre-flight inspection.
2. It is recommended to take photos or videos in low-speed or medium-speed gear.
3. Choose sunny and less windy weather for shooting.
4. Push the stick as little as possible during the flight to make the Aircraft fly smoothly.

# 7 Appendix

## 7.1 Specification Parameter

Drone	Model	U11MINI 4K
	Maximum Takeoff Weight	249g
	UAS Class	C0
	Motor Model	1503
	Operating Temperature Range	32° to 104°F (0° to 40°C)
	Satellite Systems	GPS / GLONASS
	Flight Environment	Outdoor / Spacious Indoor
	Maximum Wind Resistance Level	Level 5
	Propeller Weight	0.6 g
	Propeller Radius	61.5 mm
	Maximum Propeller Speed	3400 rad/min
	Dimensions (L x W x H)	Unfolded: 32x19.2x5.8 cm
		Folded: 14.1x8.7x5.8 cm
Camera	Controllable Range of Camera (Up and down)	About -90° to +0°
	Camera Weight	About 25.7 g
	Focus Range	Fixed-focus
	Resolution of Photo	Phone 3840×2160P
		SD Card 8000×6000P
	Resolution of Video	Phone 1280×720P / 30FPS
		SD Card 3840×2160P / 30FPS 1920×1080P / 60FPS
	Photo Format	JPG
	Video Format	MP4
Supported SD Cards	Micro SD card(Class 10/U1 or later) 256G	
Supported File Systems	FAT32	
5G Transmission	Operating Frequency	5.15-5.35 GHz; 5.725-5.825 GHz
	Video Transmission Frame Rate	30 FPS
Remote controller	Remote Controller Weight	About 358g
	Manufacturer	Ruko
	Model Number	Ruko-UD-UA36M
	Battery	1500 mAh Li-polymer
	Charging Time	About 80 minutes
	Operating Voltage	7.4V
	Mobile Device Holder	4.7 to 6.7 inches Smart Phones
	Operating Temperature	32° to 104°F (0° to 40°C)

<b>Drone Battery</b>	Capacity	2200mAh
	Voltage	7.6V
	Battery Type	Li-polymer
	Power	16.72Wh
	Net Weight	93 g/3.28 oz
	Max Charging Time	About 3 Hours(Depending on Charging Power)
	Charging Temperature Range	41° to 104°F (5° to 40°C)
<b>Charging Cable</b>	Interface Type	Type - C
	Input	100 - 240V, 50/60Hz, 0.5A
	Output	5V/1.5A or 5V/2A or 5V/3A
	Rated Power	≤ 15W
<b>App</b>	App Name	Ruko U11
	Mobile Phone System	Android 6.0 And Above System IOS 10.0.2 And Above System
	Connection Mode	Data Line Connection

## 7.2 Accessories



Intelligent Flight Battery



Spare Propeller



Remote Controller

- Always use original accessories. The use of non-original accessories may pose a risk to the safe use of the aircraft.
- It is forbidden to install any accessory or payload not included in the original packaging of the UA or not approved by the manufacturer.
- The remote pilot is responsible for ensuring that the mass of the UA does not exceed the Maximum Takeoff Mass (MTOM) as specified in the manufacturer's instructions.

## 7.3 Common Problems and Solutions

Question	Reason	Solutions
The drone cannot be unlocked	No GPS signal (green light flashing)	Fly in an open area with a strong GPS signal
	Compass interference (green light off)	Complete the compass calibration, For details, refer to page 55 of the manual
	Gyroscope calibration in progress (green light flashes rapidly for 1-2 seconds)	Place the drone on a level surface and wait for the gyroscope calibration to complete
	Drone has low battery (drone shows red light)	Please charge the battery in time
	The left and right joysticks are not in place	Push the left stick to the 5 o'clock direction and the right stick to the 7 o'clock direction simultaneously, or use the one-key takeoff function in the App
Flight is unstable	Flying too low, affected by airflow	Please fly the aircraft above 9,84ft(3 meters)
	The gyroscope is not calibrated	Place the aircraft on a horizontal surface and conduct gyroscope/horizontal calibration,For details, refer to page 58 of the manual
	The propellers become deformed and incomplete	Replace the propellers with new ones
	GPS signal is unstable. Flying near buildings or in obstructed places	Fly the aircraft in an open, obstacle-free area within a 32,81ft (10 meter) radius
Fly not far, fly out a distance to bounce back	In beginner mode, you will only be able to fly 30 metres in height and 30 metres in distance	Enter the setting interface of App, turn off the beginner mode, set the flight distance and height, and save the Settings
	When the drone enters the first low battery level, it can only fly up to 30 meters high and 30 meters far	Change to another battery for flight
After the drone is unlocked, it flips to the side during takeoff	4 propellers are installed backwards or a wrong propeller is installed	When installing the propeller, install it according to the corresponding mark
The drone suddenly crashed	1.The battery is not installed properly 2.The propeller is not securely installed and falls off	Check whether the battery or propellers is abnormal, and re-test after firm installation

Question	Reason	Solutions
Out of control, spinning around on its own, abnormal sound	Compass interference	Please manually land the aircraft in time and calibrate the compass. Please make sure to fly away from the buildings, trees, power lines, and signal towers
	The propellers become deformed and incomplete	Replace the propellers with new ones
Blurry or unclear image	The camera cover is not removed	Remove the camera cover before flying
	The camera lens is dirty	Use a clean cloth to clean the lens
	The lens film has not been removed	Please remove the lens film
	The video saved on the phone is only in 720P quality	Please insert an SD card into the drone, as videos saved on the SD card are in 4K quality
Video freezes, image transmission distance is short	Long-distance flight, with the transmission signal affected by obstacles	1. Choose a wide-open flying environment and ensure the drone's flight altitude is higher than the surrounding obstacles 2. Point the remote controller towards the drone's flight position
	Phone performance freezes	Close unused Apps running in the background to maintain the best performance of the phone
No image is displayed on the App	The phone is not connected to the remote controller	The phone and remote controller need to be connected via a cable. Please select the correct cable and ensure the connection is secure
	Wrong App downloaded	Download the correct App (Ruko U11)
	The drone cannot be paired with the remote controller	It takes about 30 seconds for the drone and the remote control to match, and the image captured by drone will be displayed once the match is successful
App crashes or functions abnormally	Wrong App downloaded	Download the correct App (Ruko U11)
	Some phone versions are old and incompatible with App	Please provide version and model of the phone, we will try to help you to solve it
GPS signal is weak	When the drone is indoors	GPS signals cannot be found indoors. Please search for GPS signals in an open area
	Under the tree, next to the building, in an obstructed place	Please stay away from obstacles for more than 32,81 feet(10 meters), and search for GPS signals in an open area

Question	Reason	Solutions
Unable to return home, drifting and flying away	The drone has lost GPS signal	Fly away from buildings or covered areas
	The drone's compass is being interfered with	Stay away from metal devices, electronic equipment, or signal towers
The remote control and the drone take a long time to match	It takes about 30 seconds to match the remote to the drone	Please wait patiently
Unable to charge battery/Not fully charged	Using inferior charger or charging on the computer with unstable voltage output	Ensure you use a charger with stable output power. Do not use a charger with an output lower than 5V
	Using inferior charging cables	Please use the original factory charging cable to charge
Short battery life	Flying in windy weather	Flying in windy weather will accelerate power loss
	The drone was not be charged when you received it	The batteries are fully charged with the correct USB charger before flying
	Flying in cold weather	In low temperatures, the chemical reaction of the lithium battery is slowed down and the energy cannot be fully released
The product has slight marks	We tested all drone before shipping	In order to give you the best experience, we tested functions of all drone before shipping. Therefore, it is inevitable that there will be slight traces. However, it can be guaranteed that all drone are 100% brand new



# **Ruko**<sup>®</sup>

rukotoy.com

CONTACT US FOR MORE TECH SUPPORT

 +1 (888)892-0155 | Mon-Fri 7:00AM - 7:00PM (PST)

 +1 (732) 207-0697  [rukodrone@gmail.com](mailto:rukodrone@gmail.com)

