

---

# TBS OBLIVION FPV Racer

Revision 2018-05-14

*Ultra strong and lightweight fpv racer*



Perfect ready to fly racing, freestyle or dynamic aerial cinematography! Defy gravity at 120km/h (80mph) in nearly indestructible, insanely aerodynamic and ultra lightweight drone. Powerful OSD functions to allow tuning every aspect of your drone. HD camera mounts included. Up to 11 minutes hover time or 2.5 minutes of full throttle! Ready to fly out of the box.

## Key features

- Lightweight fpv racer
- Box-shaped ultra strong frame
- Easy battery release and protection skid
- Quick propeller replacement kit
- Cobra 2205 2400kV motors, HQ 5x4.5x3 Props
- TBS POWERCUBE with COLIBRI F3, 20A ESCs and FPVISION OSD/VTX
- Fully configurable via OSD, no PC required
- GoPro Hero and Session HD camera mounts
- 315g weight excl. battery and HD camera



---

# Table of content

## [Attention](#)

[Disclaimer](#)

## [Overview](#)

[Quick Start Guide - RTF set](#)

[Detailed Setup](#)

[Binding using CROSSFIRE receiver](#)

[Installing the receiver](#)

[Receiver configuration for Crossfire/CRSF](#)

[System calibration](#)

[Adjusting camera tilt angle](#)

[Putting on propellers](#)

[Mounting battery](#)

[Adjusting camera focus](#)

[Mounting HD camera](#)

[Flight Controller](#)

[Calibration](#)

[Flight modes](#)

[Simulator](#)

## [Replacing parts](#)

[Replacing canopy](#)

[Replacing receiver](#)

[Replacing COLIBRI FC](#)

[Replacing speed controller](#)

[Replacing VTX antenna socket](#)

[Replacing FPVISION](#)

[Replacing power cable](#)

[Replacing FPV camera](#)

[Replacing motors](#)

## [Further Configuration](#)

[OSD Boot up messages](#)

[Entering OSD configuration menu](#)

[R/C calibration](#)

[Changing VTX channel](#)

[Changing VTX power level](#)

[COLIBRI FC configuration](#)

[OSD configuration](#)

[On-Screen Display](#)

[Flight Controller](#)

[Video Transmitter](#)

## [Firmware upgrade](#)

[Installing TBS Agent](#)

[Updating CORE PRO/FPVISION](#)

[Updating COLIBRI RACE firmware](#)

## [Good practices](#)



## Specifications

<b>Type:</b>	200-size quadrotor FPV racer
<b>Frame:</b>	Box-shaped, lightweight, strong, composite molded polymer
<b>Propellers:</b>	HQ 5x4.5x3 V3 tri-blade propellers
<b>Motors:</b>	Custom Cobra CT-2205 2400kV motors
<b>Battery:</b>	>1300 mAh 4S 14.8V 50C LiPo battery pack, dimensions unrestricted - 1300 to 2200 mAh recommended
<b>Power drive:</b>	TBS POWERCUBE with TBS COLIBRI RACE layer, fastest F3 BetaFlight 3.3 board available, BLHeli-S Multishot TBS POWERCUBE 20A (50A peak) 6S ESC layers, TBS FPVISION power supply layer
<b>R/C systems:</b>	Receiver compatibility with CRSF, PPM, SBUS and SPEK control signal (COLIBRI UART1)
<b>FPV camera:</b>	TBS OBLIVION FPV 650 TVL pilot camera, 2.5mm lens, tilt adjustable 10 to 60° with two different cam mounts
<b>Video transmitter:</b>	TBS FPVISION 5.8 GHz 24/37-channel user selectable 25/200/500/800mW Default Band A, CH1 5865 MHz
<b>VTX antenna:</b>	SMA socket, stubby 5.8GHz omni-directional FPV antenna recommended
<b>HD camera:</b>	GoPro Hero and GoPro Session cinematography mounts included
<b>Flight time:</b>	11 minutes hover time, 2.5 minutes full throttle race time
<b>Range:</b>	5 km (requires TBS CROSSFIRE or compatible long range system, included in RTF)
<b>Max. altitude:</b>	4000 m ASL
<b>Working temperature:</b>	0 - 40°C
<b>Weight:</b>	345g weight without battery and HD camera
<b>Kit contents:</b>	RTF kit: 1x TBS OBLIVION RTF, 8x HQ 5x4.4x3 propellers, 1x battery skid and strap, 2x HD camera mounts and strap, 1x Stubby antenna, 1x Propeller mounting kit, 1x ZeroZero Pilot camera backplate



---

## Attention

Thank you for buying a TBS product! The TBS OBLIVION is a new racing multirotor aircraft from Team BlackSheep (TBS). It features the best design practices available on the market to date.

A general rule for RC aircrafts is that they must be controlled always under sight of view, check your RC regulation to keep up to date with regulations.

Please read this manual carefully before assembling and flying your new TBS OBLIVION quadcopter. Keep this manual for future reference regarding tuning and maintenance.

## Disclaimer

Our request to you; the aircraft may not be used to infringe on people's right to privacy. We have designed a toy with mind blowing capabilities. It is your responsibility to use it reasonably and according to your experience level. Use common sense. Fly safe. You are on your own. TBS has no liability for use of this aircraft.

- Locate an appropriate flying location
- Obtain the assistance of an experienced pilot
- Practice safe and responsible operation
- Always be aware of the rotating blades
- Prevent moisture
- Keep away from heat or excessive amounts of sunlight



# Overview

The following diagram shows the main features of the frame and the layout of the internals.

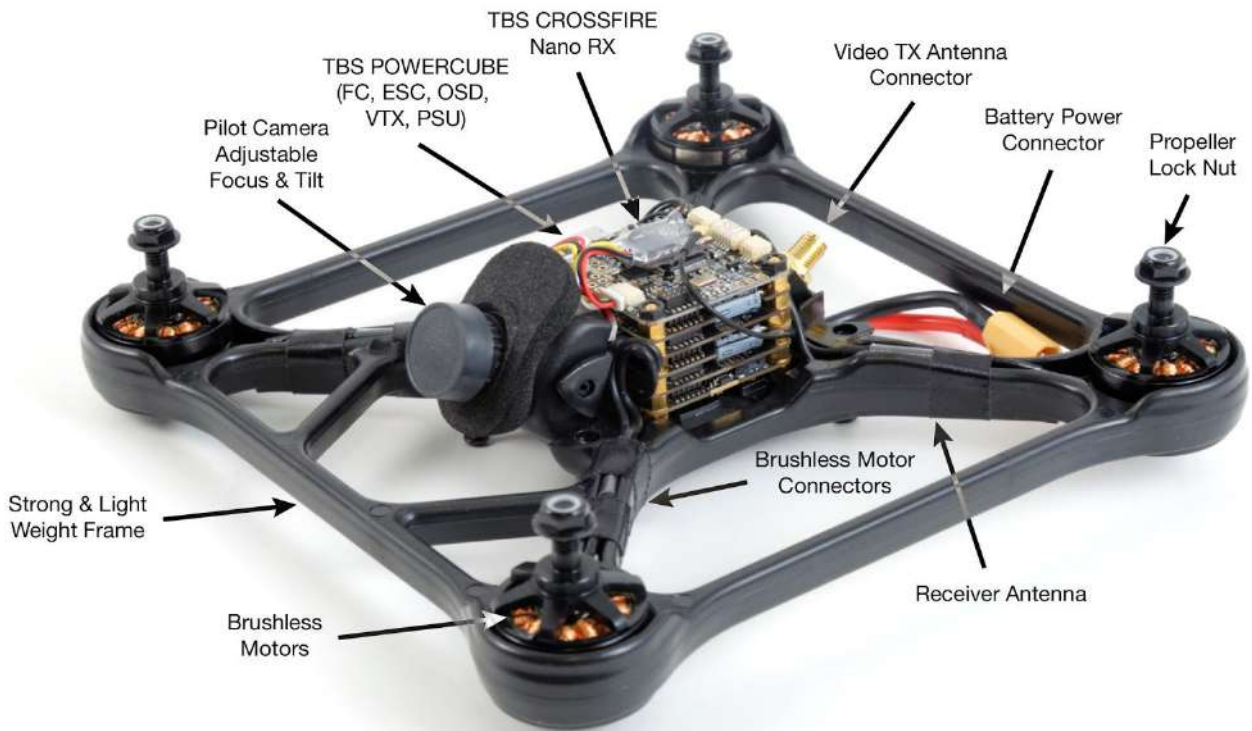

---

## Quick Start Guide - RTF set

The following steps will get you setup and ready to fly quickly. It is a condensed version intended for experienced pilots. Each step is elaborated in more detail in this manual if you are new to this.

In the RTF set, you will only need to adjust VTX frequency if necessary, insert the battery and go fly.

### Let's go!

1. Plug in the Battery to power on the OBLIVION and TBS Tango, tune into Band A CH1 5865 MHz to begin the software configuration.
2. To set the video transmitter power, enter the configuration menu (down-left) and go to "CALLSIGN" and enter your own HAM call sign (required), go back and to "GENERAL" and "VIDEO TRANSMITTER", make your changes to the desired band, channel and transmission power. If you do not have a HAM callsign, consider completing a HAM license test in order to qualify for all high power settings of the video transmitter.
3. Adjust the camera angle if needed, limited adjustments possible with the installed camera mount. Change camera to the higher angle camera mount if necessary.
4. Be sure to place yourself in a safe distance of the drone. Spin up the propellers by holding throttle down and arm by pulling Switch C towards you.

Factory configured remote control overview for the TBS TANGO is shown below. The control layout is the most common "Mode 2". Arm and flight modes switches are mapped to the top switches.



---

## Things to Note

1. The Tango in the RTF set comes pre-installed with a limiter in both beginner and intermediate mode to assist with getting used to the power and speed of a racing drone. Beginner mode is limited to 60% of the throttle curve, intermediate mode is limited to 80% of the throttle curve. To remove this limitation, simply create a new "DRONE" in the Tango screen using the FC type "Betaflight" (all other options left default).
2. You can switch the propeller rotation direction to achieve better performance of your drone. You can do this by reversing the motor direction in Betaflight, reversing all ESC directions in BLHeli Suite and also changing the propellers for each motor to match. The benefits are less likelihood of shoving debris onto your lens, and a slightly increased cornering ability as well as top speed.
3. You can zip tie the XT60 connector cable to one of the rear arms in order to protect the internal PCB from getting pads ripped out in hard crashes.



## Detailed Setup Instructions / Oblivion PNP

Getting set up and ready to fly is a quick and simple task, as mostly everything comes pre-built from the TBS factory. When using TBS equipment, it is plug & play to get ready. Follow these easy steps and you will be shredding the sky in just a few minutes!

### Installing the receiver

You can install any receiver supporting PPM/SBUS/SPEK or CRSF. It is recommended to use CRSF or SBUS where available for lower latency and best resolution/precision.

Open the OBLIVION by removing four screws on the bottom side of the frame, and pull up the canopy to reveal the internals.



For CRSF we recommend UART 1 using the "5V" cable included in the PNP set. For SBUS receivers, we recommend soldering to the 3 pads marked "SIG", "GND", "5V" near the UART2 socket (see photo below).

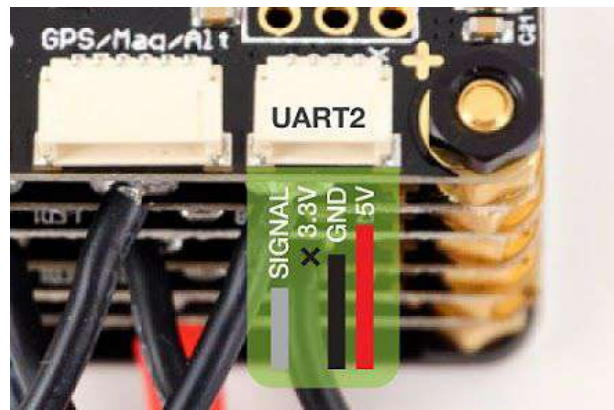

Prepare a new custom receiver cable by using a JST Micro SH 1.0 mm 4-Pin lead to interface with your receiver. Note that the new lead connects to the **UART2 port**, not UART1 as with the CROSSFIRE Nano RX.

**Pin-out:**    **Red = 5V**    **Black = Gnd**    **White = control signal (PPM/SBUS/SPEK)**    **Yellow = not used**





Position the receiver on top of the POWERCUBE with a adhesive pad and feed the receiver antenna leads down through the side to the frame arms. For further instructions please consult the TBS PowerCube manual/

Pairing the radio and receiver as covered in your receiver's manufacturer instructions. For further instructions on installing receivers please consult the TBS PowerCube manual.

## Binding using CROSSFIRE receiver

The OBLIVION RTF set comes with the CROSSFIRE Nano receiver already installed, you only need a radio with CROSSFIRE TX module installed to get started. Note: update CROSSFIRE TX to **v2.24** or newer firmware for Nano RX support!

First, install the stubby VTX antenna to avoid overheating the FPVISION board during setup.



Power on the radio and OBLIVION, the CROSSFIRE Nano receiver will enter bind mode automatically since it was not bound before.

Open the CROSSFIRE configuration menu and select "Binding" mode (On TANGO, go to "Device" then "CROSSFIRE TX"). The CROSSFIRE TX status LED will turn blue and then green once bound to the receiver. The receiver might need an update in order to proceed, allow it to update.

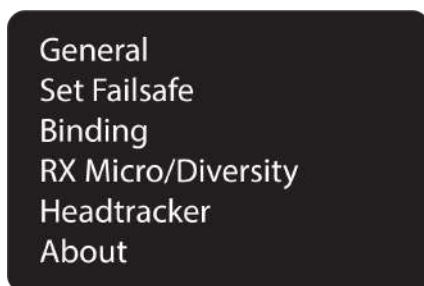

Configuration menu on TBS CROSSFIRE TX module OLED display

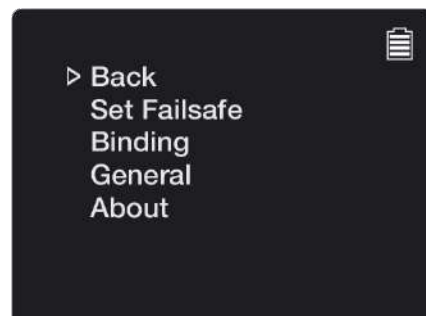

Configuration menu on TBS TANGO fpv remote with TBS CROSSFIRE TX module



## Receiver configuration for Crossfire/CRSF

To set up COLIBRI and CROSSFIRE Nano to use the CRSF control- and telemetry-protocol, you need to configure the receiver to output the CRSF protocol.

Power on the CROSSFIRE TX and Nano RX, open the CROSSFIRE TX configuration menu, go to the Nano TX settings and change the channel map for CH1 and CH2 to "CRSF RX" and "CRSF TX".

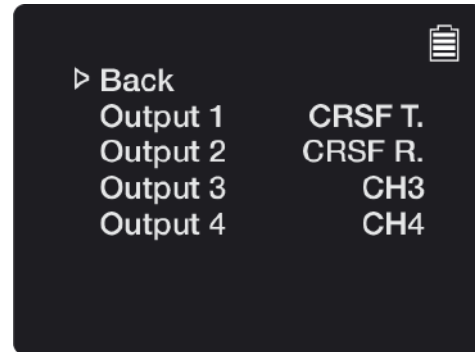
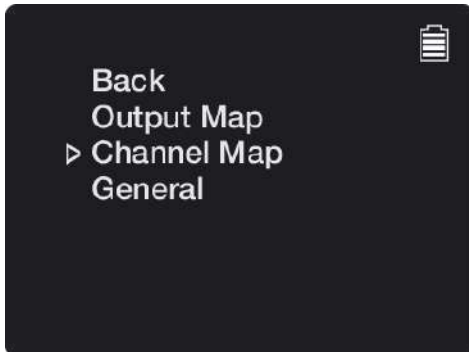

## System calibration

The initial setup of the COLIBRI and CORE PRO requires the FPV video feed to be on channel Band A CH1 5865 MHz. The configuration is done via the CORE PRO "ENTER"-button on the side of the OBLIVION and R/C radio stick movement as prompted on the OSD screen.

In order to make the OBLIVION recognize the type of the R/C signal (CRSF/PPM/SBUS/SPEK), the COLIBRI FC has to be switched to the correct protocol. This is initially done by pressing the "ENTER"-button, as shown in the following pictures, until the correct receiver protocol appears on the OSD.

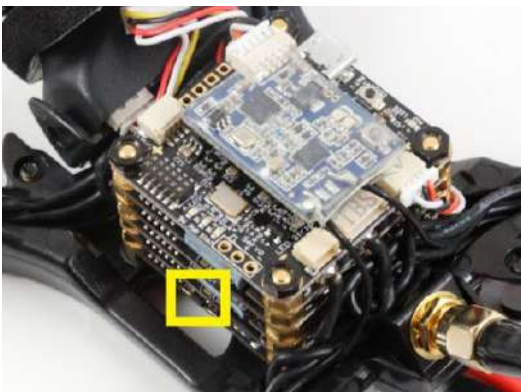

Press the "ENTER"-button on the side of the OBLIVION (as indicated) to cycle signal protocols.

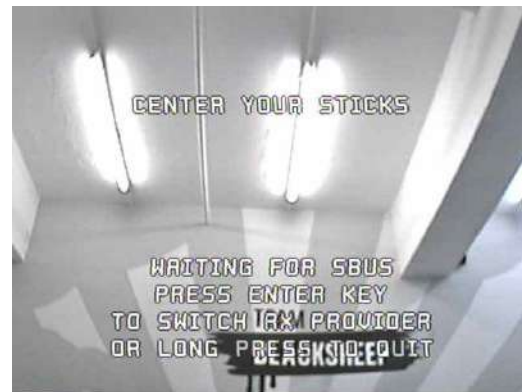

Centering your sticks will start the countdown. If you are not using the currently-active RX provider (in this case SBUS), push the ENTER-button of the CORE PRO to cycle through the available options.



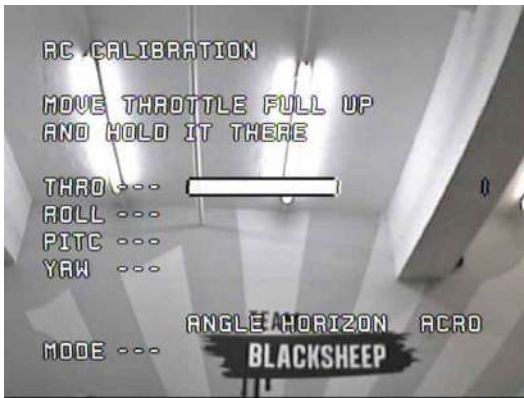

Follow the instructions on the screen and move your sticks accordingly. If the direction does not match, it needs to be adjusted in your R/C radio configuration. BetaFlight can not interpret reversed channels.

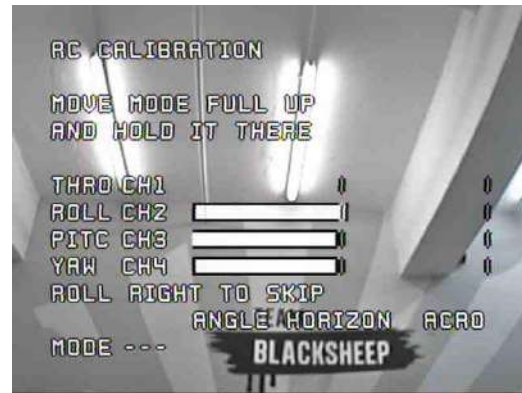

Calibrating flight modes is not required. You can ROLL RIGHT to skip, or assign a free 3-pos switch in your R/C to take advantage of this feature. Keep in mind that the default flight mode for BetaFlight is ACRO/AIRMODE.

## Adjusting camera tilt angle

The angle of the FPV pilot camera can be adjusted to provide a better view depending on your flying style. A 15° tilt is recommended for beginner flyers and higher for fast forward flight and more advanced pilots to compensate for the crazier speeds. An additional camera backplate is included for steeper camera tilt angles. The higher the tilt, the faster the drone at level camera angle flying forward.

Use a hex screwdriver to loosen the screw from the underside of the frame. Adjust the angle to the desired position and re-tighten the screw. Be careful not to over-tighten as it may crack the camera fastener.



## Putting on propellers

The provided propellers has two rotational profiles, counter-clockwise and clockwise. Getting these right is important for a safe and proper first flight. The kit comes with two sets of three-blade 5x4.5-inch props.

Separate the propellers into two bulks, with the characters on the blades facing up; counter-clockwise and clockwise.



Use the picture above to install the propellers on the motor shafts and use the provided M5 locking nuts to securing them in place. An easy way to remember the rotation is that the leading-edge/tip of the two front propellers always face each other and likewise on the tip of the two rear propellers.

Use the provided mounting kit to make it super easy to hold the motor while fastening the lock-nut screw. Do not over-tighten the propellers as it may break the prop tool.



## Mounting battery

The battery installs on the bottom of the frame with a skid to protect it from damage on rough landings, in addition to a rubber pad on the frame to keep it in place. A wide range of batteries to be used, but recommended sweet spot is 4S 1300mAh to 1800mAh. The stock flight controller settings/tuning require a 4S battery for best performance.

It is important that you adjust the position of the battery as needed to achieve **perfect center-of-gravity, which is in the middle of the frame.**

Feed one of the smaller battery strap through the tight cap on the left side, with the "TEAM BLACKSHEEP" text facing up and loop it through the hook - it can be tricky but wiggle it until the end passes through the gap.



Now, slide in the battery, either lying flat or on the side, power lead to the side between the strap, and tighten it down to properly secure it.



---

When you are ready to tune and test fly, just plug in the XT60 cable to the XT60 lead from the frame to power up.



### Adjusting camera focus

Power on the OBLIVION and FPV system to get a picture, loosen the adjustment ring just behind the lens. Turn the lens until the picture is in perfect focus, fasten the adjustment ring again.



---

## Mounting HD camera

A GoPro, Mobius or Runcam be mounted on top of the frame to capture beautiful HD footage.

Included in the kit is a special cinematography canopy, two different 30° tilt foam mounts and a large strap. The mounts are made mainly with the GoPros in mind, specifically the normal GoPro series (left picture) and GoPro Session (right picture) series.



Assembly the mounts and insert the HD camera. On the normal GoPros, there is a U-clip you can use to properly secure it.



---

## Flight Controller

### Calibration

Before the first flight, the FC needs to know the absolute flat and level position relative to the earth's surface. Calibrating the accelerometer and gyro is easily done using a bubble/spirit level and stick inputs from the radio.

1. Power up the OBLIVION and radio, remaining disarmed for the duration of this process
2. Put the spirit level on one of the arms and put a pieces of paper underneath each arm to get an absolute level reference
3. For the accelerometer, move the **throttle stick up-left** and **pitch down-center**, you will hear a confirmation beep
4. Now for the gyro, move the **throttle stick down-left** and the **pick down-center**
5. You can also do this in the first BetaFlight screen if you prefer a more visual calibration

For reference, see this list for all the BetaFlight stick operations (credit CleanFlight repository):

#### Mode 2 Stick Functions

Arm			In-flight Calibration Controls		
Disarm			Trim Acc Left		
Profile 1			Trim Acc Right		
Profile 2			Trim Acc Forwards		
Profile 3			Trim Acc Backwards		
Calibrate Gyro			Disable LCD Page Cycling		
Calibrate Acc			Enable LCD Page Cycling		
Calibrate Compass			Save Setting		

Note: stick-arming and disarming is disabled when arming via Switch C is enabled. Refer to Betaflight/Cleanflight documentation for more info.

### Flight modes

The OBLIVION has three flight modes to accommodate most flying styles.

- **Angle:** Easy mode, similar to DJI Attitude mode, the roll and pitch axis are limited to 45° angle
- **Horizon:** This mode is very flexible, there is no angle limit, you can do roll and barrels but if you let go of the sticks (hands off the radio), the OBLIVION will stabilize automatically
- **Acro/AirMode:** full manual mode, simple but allows full acrobatics, for experienced pilots/racing

### Simulator

The OBLIVION is supported by the Velocidrone FPV simulator. If you would like to practice virtually before hopping onto the real thing, perhaps saving you a few broken propellers at the same time. Visit our website and click on "SIMULATOR" for more information.





---

## Replacing parts

The best part of the OBLIVION is that all parts are modular and can be replaced without soldering or adapting parts. It is all plug & play and can be done in the field or in the car in a snap with a small toolkit.

### Replacing canopy

Remove the four screws on the underside of the frame, it is the ones outside the frame arms.



### Replacing receiver

Disconnect the control signal cable (RED, BLACK, WHITE/YELLOW) and BST cable (ALL BLACK), untangle the coax antenna cable from the underside of the frame.

Lift the receiver from the top of the COLIBRI FC, it is kept in place with a double sided adhesive pad.



---

## Replacing COLIBRI FC

Use the TBS POWERCUBE 5mm hex nut screwdriver (available separately) or use a plier to carefully remove the four top nuts. Use a plastic spudger to lift the board from all four corners at the same time (avoiding bending the pin header). Replace with a new COLIBRI board, reprogram it using BetaFlight.



## Replacing speed controller

Use the TBS POWERCUBE 5mm hex nut screwdriver (available separately) or use a plier to carefully remove the four top nuts. Use a plastic spudger to lift the board from all four corners at the same time (avoiding bending the pin header).

Remove the tape from the arm to release the bullet connectors. Unplug and replace with a new ESC. No programming needed.



The order of which the ESCs are installed is important. The bottom ESC should connect to the front-left motor, second last to the back-left motor, third last to the front-right and the top to the back-right.



---

## Replacing VTX antenna socket

Remove the entire POWERCUBE stack, either from the bottom four screws or by removing all the boards from the top. Remove the locking nut from the SMA connector using a plier. Feed the socket through the holder and replace with a new lead.

Make sure to bend the heat-shrink end of the coax a bit down, otherwise it will be in the way for the FPVISION board.

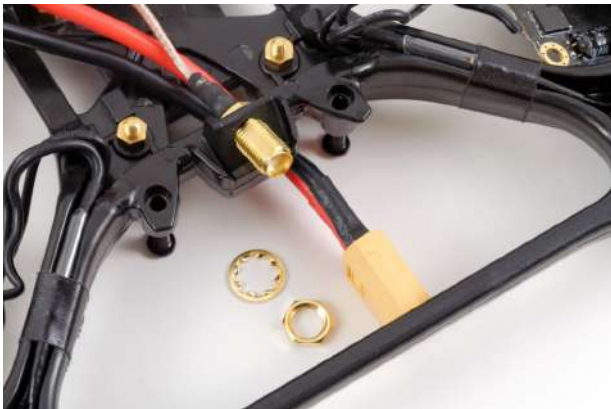

## Replacing FPVISION

Use the TBS POWERCUBE 5mm hex nut screwdriver (available separately) or use a plier to carefully remove the four top nuts. Use a plastic spudger to lift the board from all four corners at the same time.

Disconnect the FPV camera cable and VTX antenna coax cable. Note that the U.FL connector is held in place by a raised support pad on the frame when installed. Remove the VTX antenna coax socket. Feed the XT60 connector through the slot in the frame. Replace with a new board, reprogram it via the OSD or TBS AGENT.

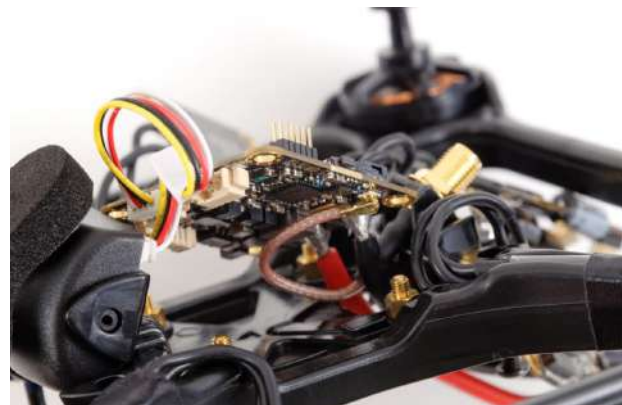
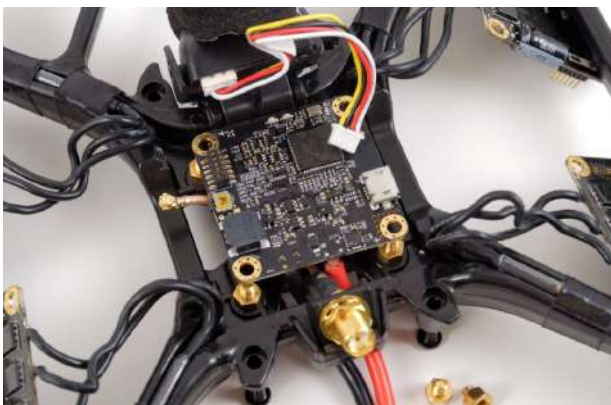

---

## Replacing power cable

Remove the entire POWERCUBE stack, either from the bottom four screws or by removing all the boards from the top. Remove the VTX SMA socket and feed the XT60 connector through the slot in the frame. Unsolder the power lead and replace with a new one.



## Replacing FPV camera

From the underside of the frame, use a ball point hex key to remove the screw holding the camera secure. Press from the underside of the camera so it snaps free from the support bar.



To get access to the other end of the camera lead, remove the four hex screws from the underside of the frame holding the POWERCUBE stack in place. Disconnect the lead from the CAM1 socket on the FPVISION board. This is only necessary if you need to replace the camera lead. Replace the camera with a new unit.

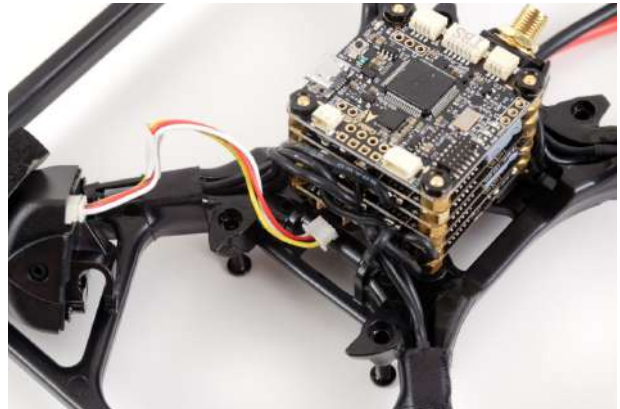

Remove the two Phillips screws from the back of the camera and replace the backplate with the desired tilt angle you prefer. Reassembly the unit, making sure not to get any dust particles on the image sensor.



## Replacing motors

Use a hex screwdriver to remove the four screws on the underside of the frame arm. Loosen the fibertape holding the bullet connectors to the frame.



Disconnect the bullet connectors and make a note of which order the lead exits the motor casing, this makes it easier to get the spinning direction right at first try.



If the motor is spinning the wrong direction, swap either two of the bullet connects to change the direction.

The maximum motor size that fits within the protective bounds of the frame is  $\text{Ø}28.4\text{mm}$ . Motor mounting holes are compatible with Cobra style or open bottoms. Only two screw holes can be used for 16x16mm or 19x19mm mounting pattern motors. 230x-class motors may fit, but just barely. Sanding may be required. We have verified that Steele V2 motors fit, MasterPilots motors need sanding.

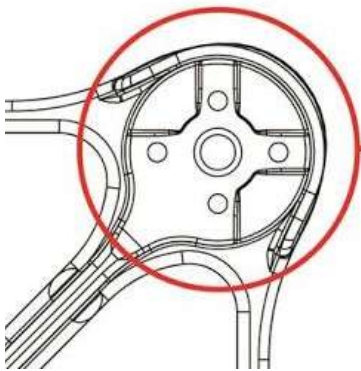

## MOTOR INSTRUCTION

Maximum diameter : 28.4mm



---

## Further Configuration

Changing settings on the TBS OBLIVION (CORE PRO, POWERCUBE, UNIFY PRO) is all done through the OSD and R/C radio inputs, using the sticks to navigate the menus and make changes. Further in-depth changes of the COLIBRI flight controller can be made via the USB-interface.

- POWERCUBE manual: <http://www.team-blacksheep.com/tbs-powercube-manual.pdf>
- CORE PRO manual: <http://www.team-blacksheep.com/tbs-core-pro-manual.pdf>
- UNIFY PRO manual: <http://www.team-blacksheep.com/tbs-unify-pro-5g8-manual.pdf>
- COLIBRI/BetaFlight wiki: <https://github.com/betaflight/betaflight/wiki>

**Warning: remove the propellers before setting up the quad for the first time!**

To enter and navigating the menu system:

- Configuration menu - both sticks on center position, also throttle
- Menu navigation - scroll back and forth using the roll- and pitch-stick
- Select/enter change - left press roll- and pitch-stick

## OSD Boot up messages

When power is applied, the OSD will engage and show you a boot up summary screen. Verify that the following devices have been detected:

- **TBS CORE PRO V2** - Responsible for CAM, OSD, PSU, and GPS - binding it all together
- **BAND A CH:1** - Current VTX frequency that will broadcast on
- **SELF TEST** - TBS: WHAT DOES IT DO?
- **PCUBE C.SENS V2** - Detected TBS POWERCUBE on-board current sensor on FPVISION board
- **CROSSFIRE** - Detected TBS CROSSFIRE RX connected via BST to COLIBRI
- **COLIBRI FC V3.2** - Detected TBS COLIBRI Flight Controller on the POWERCUBE stack
- **BATTERY: 4S BATTERY** - The battery type (based on voltage) detected

## Entering OSD configuration menu

When you have a working R/C setup, you can enter the OSD configuration menu using the radio sticks.

1. To enter the OSD configuration menu, hold the throttle stick down-left for 4 seconds (mode 2)



2. A countdown will let you know that you are about to enter the OSD menu



---

## R/C calibration

CORE PRO needs to be calibrated/mapped with the channel mapping from BetaFlight. Go into "FLIGHT CONTROLLER", "CALIBRATION" and "READ FLIGHT CONTROLLER RC DATA". This maps the settings to the CORE PRO and you are ready to go. Required procedure every time the R/C channel inputs are changed.

## Changing VTX channel

The UNIFY PRO supports 37/24-channels and changes can be made "live" via the OSD.

1. Go into the OSD menu, then navigate down to "VIDEO TRANSMITTER" using the elevator-stick on your radio, selecting it by moving the aileron-stick right
2. In this menu you can use the same navigation method to change the band and channel
3. Once preferred settings are set, use the aileron-stick to exit selection by moving to the left and navigating out of the menu, only then will the new settings be made active on the UNIFY PRO VTX

This way of configuring the VTX this way is based on what we call SmartAudio. The CORE PRO uses the audio channel from the UNIFY PRO as an exchange protocol to open a full duplex (back and forth) connection between the VTX and the OSD. It is possible to change this behaviour via solder jumper on the CORE PRO so you can either control the VTX channels and frequency via OSD, or just hear the sound from the mic.

## Changing VTX power level

The default VTX power level is 25mW and is fine for all close proximity flight where there are no other FPV pilots around. In order to unlock higher power levels, you need to change your HAM callsign. Please note that this requires a HAM license in most countries, which you are obligated to obtain before increasing the power levels or switching to non-approved frequencies.

1. Go into the OSD and navigate to "VIDEO TRANSMITTER" and "UNLOCK VTX"
2. Change the callsign from the default "TBS"
3. Return to the "VIDEO TRANSMITTER" menu and change to "VTX POWER LEVEL"
4. The transmitter power can be changed from 25mW all the way up to 800mW

For racing recommended power is maximum 200mW to avoid interference with other FPV pilots. Power levels above this is only recommended when flying alone in wide open spaces.





## COLIBRI FC configuration

The OBLIVION comes preconfigured with tuned BetaFlight settings and test flown. Changing the essential flight controller settings such as PID, rates, filters, general settings and accelerometer calibration can be made using the OSD in the field, or via the USB interface.

Changing settings via OSD:

1. Go to the "FLIGHT CONTROLLER" menu in the OSD
2. Select either "PID", "RATES", "GENERAL", "CALIBRATION" or "FILTERS"

Changing settings via USB:

1. Remove the canopy and connect a micro-USB cable to the slot on the right-side of the frame
2. Download the [CleanFlight/BetaFlight](#) app from the Google Chrome Web Store
3. Click "Connect" to get access to all the settings

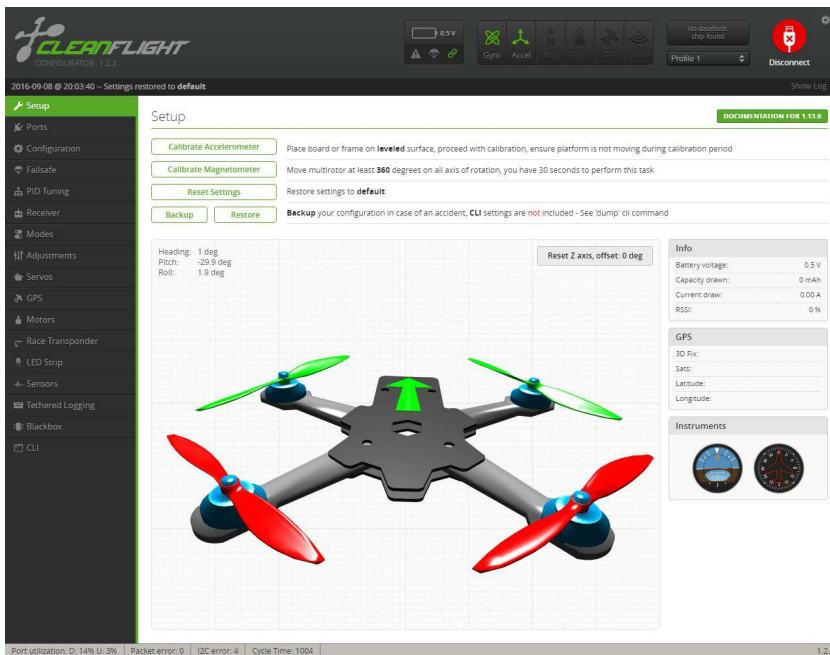

## OSD configuration

The OSD is built around the full-fledged TBS CORE PRO OSD and detailed description of all the parameters is outlined in the official manual: <http://www.team-blacksheep.com/tbs-core-pro-manual.pdf>

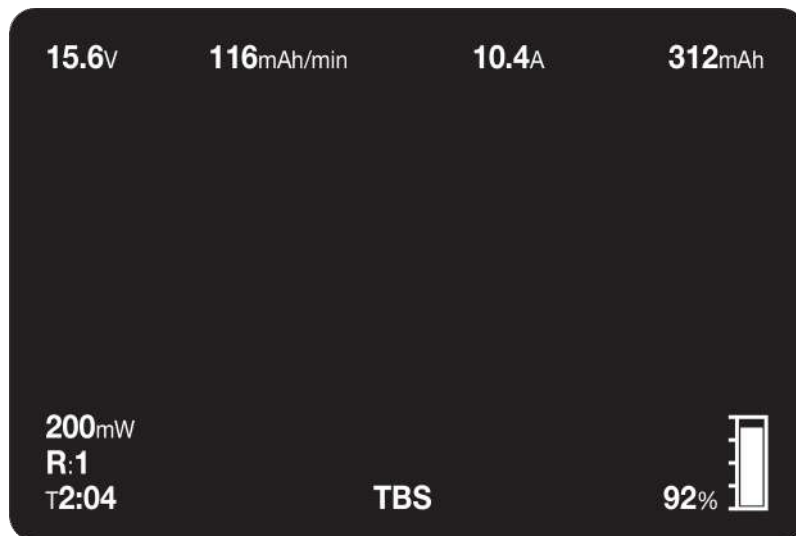

The following is a concise summary specific for the OBLIVION.

### On-Screen Display

- **Units (GPS required)** - Standard unit to use on the OSD
  - **Speed** - Metric (km/h), Imperial (mi/h), Knots (kts/h)
  - **Distance** - Metric (m), Imperial (ft)
  - **Altitude** - Metric (m), Imperial (ft)
- **RSSI** - Received Signal Strength Indicator signal from the receiver (if connected physically)
  - **Source** - Off/CrossFire/EzUHF OSD Link/Digital (PWM)/Analog (voltage) - RSSI signal source type
  - **Alarm** - Enable/Disable - Display a textual warning and the RSSI read-out will blink when the signal is critical
- **Battery** - Power system monitoring
  - **Alarm** - Enable/Disable - Show warning when battery voltage crosses critical level
  - **Level Input** - Auto/Manual - How to detect the number of battery cells/voltage
  - **Warning Level** - 0.0 to 99.9V - Set the threshold when a low voltage alarm should trigger
  - **Curr. Correction** - 50 to 250% - Calibrate your current sensor if it is a little off. e.g. your fly a battery and the OSD shows you you used 1000mAh but your charger let you charge 1200mAh, so you can set this value to 120% and the reading will match on the next flight
  - **Backup Voltage** - Disable/Enable - Enables the backup battery, if connected, so the OSD/GPS can run while the rest of the system is down, e.g. to recover a downed aircraft



- **General** - OSD specific settings
  - **Show Position** - No/Yes - Display the GPS coordinates on the bottom of the screen, update rate 1Hz - useful while watching a DVR recording to recover a downed aircraft
  - **Show Heading** - No/Yes - Show heading arrow pointing towards “home” base
  - **Show Sats** - Hide on fix/Always - Number of GPS satellites available and locked
  - **OSD Color** - White/Black - Color of text and outline, i.e. white core and black outline/glow
  - **Power Index** - Off / mAh/Min / mWh/Km mWh/Mi / mAh/Km mAh/Mi - Running indicator of power economy
  - **Warn. Show Time** - 0.5 to 60.0 Seconds - Duration of how long warnings stay on the screen, default for racers target is 0.8s and 2.5s for every other target
  - **Summary Style** - TBS/PAO/Off - End of flight summary screen layout, TBS style with judgement or without (PAO)
  - **Audio Telemetry** - Off/ImmersionRC - When you do not use TBS UNIFY, the TELM solder bridge closed and ImmersionRC decoder is attached to the VRX
  - **OSD Type:** CORE PRO/OBLIVION - Changes the power up text to CORE PRO or OBLIVION
  - **Factory Reset** - Reset all CORE PRO settings to default
- **Artificial Horizon** - Uses the gyro and accelerometer to estimate level plane
  - **Show Horizon** - Off/Basic - Shows a line in the middle of the display to indicate level position
- **Callsign** - Personal HAM licence number
  - **Show Callsign** - Minutely/Always/Off - Display the HAM callsign and mm:ss timer on the lower-left corner
  - **Enter Callsign** - 0 to 10 characters - Enter your callsign, defaults to “TBS”

## Flight Controller

- **PID** - Detailed Proportional–Integral–Derivative controller values for Roll, Pitch and Yaw
- **Rate** - Stick sensitivity multiplier values
- **Settings** - Looptime and Idle Motors settings
- **Calibration** - RC/Radio Calibration wizard for setting up the receiver or this can also be done in CleanFlight and the data read back to the CORE PRO. Run the accelerometer calibration on a leveled surface
- **Filters** - Advanced setup of Gyro and PD Cut Frequency settings

## Video Transmitter

- **VTX Unlock** - Brings you to Callsign settings to change the id from the default “TBS”
- **Band** - A/B/Race/E/Airwave/User - Video transmitter frequency band
- **Channel** - 1 to 8 - Channel number (frequency) within the selected band, see UNIFY PRO manual
- **Power Level** - 25/200/500/800mW - Transmitter output power level
- **VTX LED Strip** - Disable/Enable - Changes color depending on the frequency used, rainbow color from lowest (red) to highest (violet)



## Firmware upgrade

Updates to the transmitter and receiver are applied using our TBS AGENT software. This takes care of all the downloading of the latest firmware, verification- and upgrade process.

### Installing TBS Agent

Download the installer from <http://www.team-blacksheep.com/corepro/agent> (Windows7/8, 64-bit required) - no drivers needed to use the application, but an Internet connection is required to download the latest firmware versions.

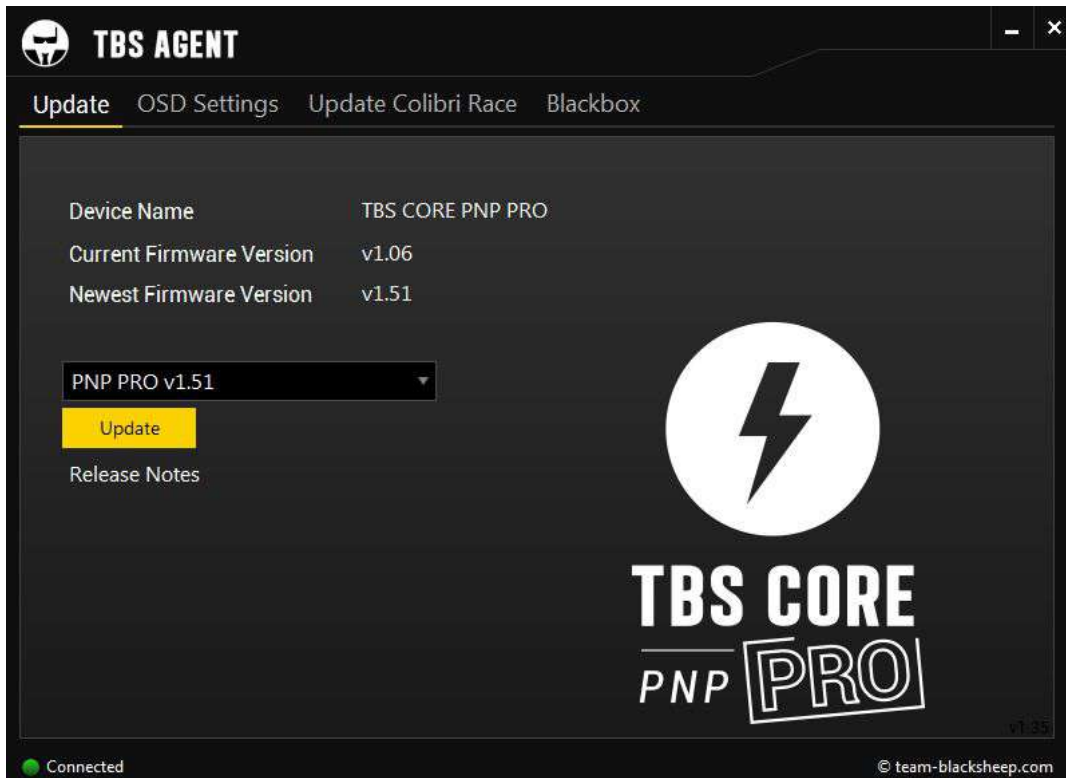

### Updating CORE PRO/FPVISION

The USB connector for the CORE PRO is located on the bottom of the POWERCUBE stack and you need to remove the canopy to get access.

1. Remove the canopy to get access to the micro-USB connector on the FPVISION board, located on the right side of the frame
2. Open TBS AGENT and connect the USB cable, select the desired version and hit "Update", finishes in under a minute



## Updating COLIBRI RACE firmware

Getting the latest firmware flashed via TBS Agent is a fast and easy process.

1. Install the latest STM32 VCP drivers: <http://www.st.com/web/en/catalog/tools/PF257938>
2. Open TBS Agent and click on the "UPDATE COLIBRI RACE"-tab
3. Press and hold the "BOOT"-button on the COLIBRI board while connecting the micro-USB cable to the connector next to it to enter DFU programming-mode that allow firmware upgrades



4. Select a firmware from the drop-down menu and click "UPDATE" - the process should finish within 15 seconds. These firmwares include tuned settings.



5. Restore OBLIVION factory settings for the particular firmware version in [CleanFlight/BetaFlight](#) by hitting "Reset Settings" on the first "Setup"-tab. Now, setup flight modes, beeper and LEDs again.



---

## Good practices

We have compiled a list of all of practices which have been tried and tested in countless environments and situations by the TBS crew and other experienced FPV pilots.

Follow these simple rules, even if rumors on the internet suggest otherwise, and you will have success in FPV.

- Start with the bare essentials and add equipment one step at a time, after each new equipment was added to proper range- and stress tests.
- Do not fly with a video system that is capable of outperforming your R/C system in terms of range.
- Do not fly with a R/C frequency higher than the video frequency (e.g. 2.4GHz R/C, 900MHz video).
- Monitor the vitals of your plane (R/C link and battery). Flying with a digital R/C link without RSSI is dangerous.
- Do not use 2.4GHz R/C unless you fly well within its range limits, in noise-free environments and always within LOS. Since this is most likely never the case, it is recommended to not use 2.4GHz R/C systems for longer range FPV.
- Do not fly at the limits of video, if you see noise in your picture, turn around and buy a higher-gain receiver antenna before going out further.
- Shielded wires or twisted cables only, anything else picks up RF noise and can cause problems.
- When using powerful R/C transmitters, make sure your groundstation equipment is properly shielded.
- Adding Return-To-Home (RTH) to an unreliable system does not increase the chances of getting your plane back. Work on making your system reliable without RTH first, then add RTH as an additional safety measure if you must.
- Avoid powering the VTx directly from battery, step-up or step-down the voltage and provide a constant level of power to your VTx. Make sure your VTx runs until your battery dies.
- Do not power your camera directly unless it works along the complete voltage range of your battery. Step-up or step-down the voltage and provide a constant level of power to your camera. Make sure your camera runs until your battery dies.
- A single battery system is safer than using two dedicated batteries for R/C and FPV. Two batteries in parallel even further mitigate sources of failure.
- For maximum video range and “law compatibility”, use 2.4GHz video with high-gain antennas.
- When flying with R/C buddies that fly on 2.4GHz, or when flying in cities, it is perfectly possible to use 2.4GHz video provided you stick to the channels that do not lie in their band (CH5 to CH8 for Lawmate systems, available from TBS).
- Do not use diversity video receivers as a replacement for pointing your antennas, diversity should be used to mitigate polarization issues.



- 
- Improving the antenna gain on the receiver end is better than increasing the output power (except in RF-noisy areas). More tx power causes more issues with RF noise on your plane. 500mW is plenty of power!
  - Try to achieve as much separation of the VTx and R/C receiver as possible to lower the RF noise floor and EMI interference.
  - Do not buy cheap equipment unless it is proven to work reliably (e.g. parts falling off, multitudes of bug fix firmware updates, community hacks and mods are a good indicator of poor quality and something you do NOT want to buy for a safe system). Do some research before sending your aircraft skyward to insure both you and the people around you stay safe.

Manual written and designed by ivc.no in cooperation with TBS.

